

**SAN BERNARDINO INTERNATIONAL AIRPORT AUTHORITY**  
**REGULAR MEETING AGENDA**  
**WEDNESDAY, APRIL 22, 2026**  
**5:00 PM**

MAIN AUDITORIUM – Norton Regional Event Center, 1601 East Third Street, San Bernardino, CA



A regional joint powers authority dedicated to the reuse of Norton Air Force Base for the economic benefit of the East Valley

**Penny Lilburn, President**

*Mayor, City of Highland*

**Joe Baca, Jr., Vice President**

*Supervisor, County of San Bernardino*

**Theodore Sanchez, Secretary**

*Councilmember, City of San Bernardino*

**COMMISSION MEMBERS:**

**Frank J. Navarro**

*Mayor, City of Colton*

**Rhodes Rigsby**

*Councilmember, City of Loma Linda*

**Kim Knaus**

*Councilmember, City of San Bernardino*

**ALTERNATE COMMISSION MEMBERS:**

**Dawn Rowe**

*Supervisor, County of San Bernardino*

**Phillip Dupper**

*Mayor, City of Loma Linda*

**John Echevarria**

*Councilmember, City of Colton*

**Jimmy Saldana**

*Mayor Pro Tem, City of Highland*

**Fred Shorett**

*Councilmember, City of San Bernardino*

- Full agenda packets are available at the SBIAA office, 1601 East Third Street, San Bernardino, California, will be provided at the meeting, and are posted in the Public Meetings/Agenda section of our website at [www.sbiaa.org](http://www.sbiaa.org). Office hours are 8:00 a.m. to 5:00 p.m., Monday–Friday.
- Recordings of the SBIAA Commission meetings are available in the Public Meetings/Agenda section of our website at [www.sbiaa.org](http://www.sbiaa.org).
- In compliance with the Americans with Disabilities Act, if you need special assistance to participate in this meeting, please contact the SBIAA office at (909) 382–4100. Notification 48 hours prior to the meeting will enable SBIAA staff to make reasonable arrangements to ensure accessibility to this meeting.
- Anyone who wishes to speak during public comment or on a particular item will be requested to fill out a speaker slip. Prior to speaking, speaker slips should be turned in to the Clerk of the Board.
- Public comments for agenda items that are not public hearings will be limited to three minutes.
- Public comments for items that are not on the agenda will be limited to three minutes.
- The three–minute limitation shall apply to each member of the public and cannot be shared.
- An additional three minutes will be allotted to those who require translation services.

**ORDER OF BUSINESS – CLOSED SESSION**

This meeting of the governing Commissions of the San Bernardino International Airport Authority will begin with Closed Session Public Comment and Closed Session, immediately followed by the Open Session portion of the meeting

- **CALL TO ORDER**
- **CLOSED SESSION PUBLIC COMMENT**
- **LEGAL COUNSEL RECITES CLOSED SESSION ITEMS**
- **RECESS TO CLOSED SESSION**

**A. CALL TO ORDER / ROLL CALL**

**B. CLOSED SESSION PUBLIC COMMENT**

The Closed Session Public Comment portion of the San Bernardino International Airport Authority Commission meeting is limited to a maximum of three minutes for each speaker and comments will be limited to matters appearing on the Closed Session portion of the agenda. Additional opportunities for further Public Comment will be given during and at the end of the meeting. An additional three minutes will be allotted to those who require translation services.

**C. CLOSED SESSION**

An announcement is typically made prior to closed session discussions as to the potential for a reportable action at the conclusion of closed session.

- a. Conference with Real Property Negotiator Pursuant to Government Code Section 54956.8  
Property: 105 North Leland Norton Way, San Bernardino CA 92408  
Negotiating Parties: Michael Burrows, SBIAA Chief Executive Officer and Betty Lui, Transportation Security Administration (TSA)
- b. Conference with Real Property Negotiator Pursuant to Government Code Section 54956.8  
Property: 2235 East Perimeter Road, San Bernardino CA 92408  
Negotiating Parties: Michael Burrows, SBIAA Chief Executive Officer and Kevin Horan, SBRETC
- c. Conference with Real Property Negotiator Pursuant to Government Code Section 54956.8  
Property: 275 N. Leland Norton Way, San Bernardino CA 92408  
Negotiating Parties: Michael Burrows, SBIAA Chief Executive Officer and Mike Allen, Executive Vice President, Bulk Fuel Sales, Titan Aviation Fuels
- d. Conference with Real Property Negotiator Pursuant to Government Code Section 54956.8  
Property: Approximately 4 acres of vacant land at the San Bernadino International Airport, San Bernardino CA 92408  
Negotiating Parties: Michael Burrows, SBIAA Chief Executive Officer and Michael Allowas, Technical Advisor

- e. Conference with Real Property Negotiator Pursuant to Government Code Section 54956.8  
Property: 255 S. Leland Norton Way, Suite 1, San Bernardino CA 92408  
Negotiating Parties: Michael Burrows, SBIAA Chief Executive Officer, Scott Huber, SBIAA Legal Counsel, and Joe Ermalovich, AeroPro MRO SBD, LLC

**D. REPORT ON CLOSED SESSION**

Public announcement(s) will be made following closed session if there are any reportable actions taken during closed session.

**ORDER OF BUSINESS – OPEN SESSION**

- **CALL TO ORDER OPEN SESSION**
- **PLEDGE OF ALLEGIANCE**

**E. ITEMS TO BE ADDED OR DELETED**

Pursuant to Government Code Section 54954.2, items may be added on which there is a need to take immediate action, and the need for action came to the attention of the San Bernardino International Airport Authority Commission subsequent to the posting of the agenda.

**F. CONFLICT OF INTEREST DISCLOSURE**

1. POSSIBLE CONFLICT OF INTEREST ISSUES FOR THE SAN BERNARDINO INTERNATIONAL AIRPORT AUTHORITY (SBIAA) COMMISSION MEETING OF APRIL 22, 2026  
[**PRESENTER:** Jillian Ubaldo, Assistant Secretary of the Commission **PAGE#:** 007]

**G. INFORMATIONAL ITEMS**

It is intended that the following subject matters and their attachments are submitted to the Board members for informational purposes only. No action is required with regard to these items in the form of a receive-and-file motion or otherwise. Members may inquire of staff as to any questions or seek clarifications, but no discussion may ensue other than to place an item on a subsequent agenda for further consideration. In such situations where permissible levels of discussion are conducted, members are reminded that staff has not presented the related contractor and interested parties conflicts of interest disclosures that are typically provided for agenda items for which action is intended to occur. Additionally, questions may arise as to negotiation strategies or other legal issues which are more appropriately addressed in a closed session discussion.

2. Informational Items
  - a. CHIEF EXECUTIVE OFFICER'S REPORT  
[**PRESENTER:** Michael Burrows, Chief Executive Officer **PAGE#:** 015]
  - b. SBD GOOD NEIGHBOR PROGRAM UPDATE  
[**PRESENTER:** Mark Gibbs, Director of Aviation **PAGE #:** 016]

**H. COMMISSION CONSENT ITEMS**

The following consent items are expected to be routine and non-controversial and will be acted upon by the Committee at one time unless the Board directs that an item be held for further discussion.

3. REGISTER OF DEMANDS FOR MARCH 2026  
[**PRESENTER:** Mark Cousineau, Director of Finance **PAGE#:** 017]
4. RECEIVE AND FILE TREASURER'S REPORT FOR FEBRUARY 28, 2026 FOR THE SAN BERNARDINO INTERNATIONAL AIRPORT AUTHORITY (SBIAA)  
[**PRESENTER:** Mark Cousineau, Director of Finance **PAGE#:** 025]

5. AUTHORIZE STAFF TO ADVERTISE THE GENERAL AVIATION PARKING REDESIGN PROJECT  
[PRESENTER: Jeff Barrow, Director of Development **PAGE#: 028**]
6. APPROVE MEETING MINUTES: MARCH 25, 2026  
[PRESENTER: Jillian Ubaldo, Assistant Secretary of the Commission **PAGE#: 036**]

**I. COMMISSION ACTION ITEMS**

7. CONSIDER AND ADOPT PROPOSED BUDGET ADJUSTMENTS FOR FISCAL YEAR 2025-2026  
[PRESENTER: Mark Cousineau, Director of Finance **PAGE#: 044**]
8. CONSIDER AND DISCUSS A REPORT ON AIRPORT RULES AND REGULATIONS  
[PRESENTER: Scott Huber, Legal Counsel **PAGE#: 048**]
9. ADOPTION OF RESOLUTION NO. 2026-02 ESTABLISHING THE EXECUTIVE COMMITTEE AS A STANDING COMMITTEE AND ADOPTING A REGULAR MEETING SCHEDULE  
[PRESENTER: Scott Huber, Legal Counsel **PAGE#: 050**]
10. AWARD A CONSTRUCTION CONTRACT TO ALL AMERICAN BUILDING SERVICES IN AN AMOUNT NOT TO EXCEED \$131,100 FOR THE INTER-TERMINAL WALKWAY PROJECT  
[PRESENTER: Jeff Barrow, Director of Development **PAGE#: 058**]
11. AWARD A CONSTRUCTION CONTRACT TO GEO PAVING AND SEAL COATING, INC. IN AN AMOUNT NOT TO EXCEED \$133,500.50 FOR THE GENERAL AVIATION RAMP (PHASE II) PROJECT  
[PRESENTER: Jeff Barrow, Director of Development **PAGE#: 089**]
12. APPROVE CHANGE ORDER NO. 1 WITH LEONIDA BUILDERS, INC. FOR \$19,550 FOR A TOTAL CONTRACT AMOUNT OF \$507,550 FOR ADDITIONAL WORK RELATED TO THE RE-BID AIRFIELD CANOPIES & UNDERGROUND SERVICE PIT PROJECT  
[PRESENTER: Jeff Barrow, Director of Development **PAGE#: 140**]
13. CONSIDER AND DISCUSS A REPORT ON THE GREEN ENERGY ELEMENT UPDATE  
[PRESENTER: Michael Burrows, Chief Executive Officer **PAGE#: 144**]
14. CONDUCT BUSINESS PLAN UPDATE WORKSHOP  
[PRESENTER: Michael Burrows, Chief Executive Officer **PAGE#: 185**]
15. REVIEW STATUS OF THE ACTION PLAN FOR THE SAN BERNARDINO INTERNATIONAL AIRPORT AUTHORITY (SBIAA) THROUGH JUNE 30, 2026  
[PRESENTER: Michael Burrows, Chief Executive Officer **PAGE#: 212**]

**J. ADDED AND DEFERRED ITEMS**

Deferred Items and Items which have been added pursuant to Government Code Section 54954.2 as noted above in Section E.

**K. OPEN SESSION PUBLIC COMMENT**

Anyone who wishes to speak during Open Session Public Comment will be requested to fill out a speaker slip. Prior to speaking, speaker slips should be given to the Clerk of the Board. Public comments for items that are not on the agenda will be limited to three minutes. The three-minute limitation shall apply to each member of the public and cannot be shared with other members of the public. An additional three minutes will be allotted to those who require translation services.

**L. COMMISSION MEMBER COMMENT**

Commission members may make announcements or give brief reports on activities or matters not appearing on the agenda, as well as provide direction to staff relating to matters which may be addressed at this time.

**M. ADJOURNMENT**

Unless otherwise noted, this meeting will be adjourned to the next regularly scheduled meeting of the San Bernardino International Airport Authority Commission, Wednesday, May 27, 2026.

	<p><b>TO: San Bernardino International Airport Authority Commission</b></p> <p><b>DATE: April 22, 2026</b></p> <p><b>ITEM NO: 1</b></p> <p><b>PRESENTER: Jillian Ubaldo, Assistant Secretary of the Commission</b></p>
---	--

**SUBJECT: POSSIBLE CONFLICT OF INTEREST ISSUES FOR THE SAN BERNARDINO INTERNATIONAL AIRPORT AUTHORITY (SBIAA) COMMISSION MEETING OF APRIL 22, 2026**

**SUMMARY**

This agenda contains recommendations for action relative to certain contractors/principals and their respective subcontractors. Care should be taken by each Commission member to review and consider the information provided herein to ensure they are in compliance with applicable conflict of interest laws.

**RECOMMENDED ACTION(S)**

Receive for information and consideration in accordance with applicable conflict of interest laws.

**FISCAL IMPACT**

None.

PREPARED BY:	Yajaira Maldonado
CERTIFIED AS TO AVAILABILITY OF FUNDS:	N/A
APPROVED AS TO FORM AND LEGAL CONTENT:	Scott Huber
FINAL APPROVAL:	Michael Burrows

**BACKGROUND INFORMATION**

The potential conflicts information provided in this report is intended to be used as a means for each voting member to verify campaign contributions from their individual campaign records. The following information is considered to be complete only to the best knowledge that has been disclosed to staff by the following listed contractors and in many instances may not be complete as of the date of publication of the agenda. Staff will endeavor to provide updates and supplements to the disclosure information to the extent additional contractor disclosure information becomes known to staff at or prior to each particular meeting time.

In addition to other provisions of law which prohibit San Bernardino International Airport Authority (SBIAA) Commission members from having financial interests in the contracts of public agencies, the provisions of California Government Code Section 84308 prohibit individual SBIAA Commission members from participating in any Commission proceeding involving a license, permit, or other entitlement for use pending before the Commission, if the individual member has received a contribution of more than two hundred fifty dollars (\$250.00) within the preceding twelve (12) months or for three (3) months following any such Commission proceeding, from any person, company or entity who is the subject of the proceeding, including parent-subsiary and certain otherwise related business entities as defined in the California Code of Regulations, Title 2, Division 6, Section 18438.5, or from any person who actively supports or opposes a particular decision in the proceeding and who has a financial interest in such decision, as defined in California Government Code Section 87103.

The restrictions of Government Code Section 84308 do not apply if the individual member returns the contribution within thirty (30) days from the time they know, or should have known, about the contribution and the proceeding.

This agenda contains recommendations for action relative to the following contractors/principals and their respective subcontractors (as informed to SBIAA staff by the Principals):

<b><u>Agenda Item No.</u></b>	<b><u>Contractors/Tenants</u></b>	<b><u>Subcontractors/Subtenants</u></b>
C.b.	<u>San Bernardino Regional Emergency Training Center</u>	None.
C.c.	<u>Titan Aviation Fuels</u> Robert "Buddy" Stallings, Owner Robbie Stallings, President Mike Allen, Vice President Kyle Voorhees, Southwestern Sales Representative	None.
C.e.	<u>Aeropro Corporation</u> Joseph Ermalovich, CEO/CFO/Secretary	None.

- 10. All American Building Services None.  
Anthony Innabi, CEO/CFO/Secretary
- 11. Geo Paving and Seal None.  
Khalifah Alsayegh, CEO/CFO/Secretary
- 12. Leonida Builders, Inc. None.  
Panagiotis Leonida, President/Secretary/Treasurer

**Attachments:**

- 1. California Government Code §§ 84308 and 87103
- 2. California Code of Regulations, Title 2, Division 6, §18438

CALIFORNIA CODES  
GOVERNMENT CODE  
SECTION 84308

**84308.** (a) The definitions set forth in this subdivision shall govern the interpretation of this section.

(1) "Party" means any person who files an application for, or is the subject of, a proceeding involving a license, permit, or other entitlement for use.

(2) "Participant" means any person who is not a party but who actively supports or opposes a particular decision in a proceeding involving a license, permit, or other entitlement for use and who has a financial interest in the decision, as described in Article 1 (commencing with Section 87100) of Chapter 7. A person actively supports or opposes a particular decision in a proceeding if he or she lobbies in person the officers or employees of the agency, testifies in person before the agency, or otherwise acts to influence officers of the agency.

(3) "Agency" means an agency as defined in Section 82003 except that it does not include the courts or any agency in the judicial branch of **government**, local governmental agencies whose members are directly elected by the voters, the Legislature, the Board of Equalization, or constitutional officers. However, this section applies to any person who is a member of an exempted agency but is acting as a voting member of another agency.

(4) "Officer" means any elected or appointed officer of an agency, any alternate to an elected or appointed officer of an agency, and any candidate for elective office in an agency.

(5) "License, permit, or other entitlement for use" means all business, professional, trade and land use licenses and permits and all other entitlements for use, including all entitlements for land use, all contracts (other than competitively bid, labor, or personal employment contracts), and all franchises.

(6) "Contribution" includes contributions to candidates and committees in federal, state, or local elections.

(b) No officer of an agency shall accept, solicit, or direct a contribution of more than two hundred fifty dollars (\$250) from any party, or his or her agent, or from any participant, or his or her agent, while a proceeding involving a license, permit, or other entitlement for use is pending before the agency and for three months following the date a final decision is rendered in the proceeding if the officer knows or has reason to know that the participant has a financial interest, as that term is used in Article 1 (commencing with Section 87100) of Chapter 7. This prohibition shall apply regardless of whether the officer accepts, solicits, or directs the contribution for himself or herself, or on behalf of any other officer, or on behalf of any candidate for office or on behalf of any committee.

(c) Prior to rendering any decision in a proceeding involving a license, permit or other entitlement for use pending before an agency, each officer of the agency who received a contribution within the preceding 12 months in an amount of more than two hundred fifty dollars (\$250) from a party or from any participant shall disclose that fact on the record of the proceeding. No officer of an agency shall make, participate in making, or in any way attempt to use his

or her official position to influence the decision in a proceeding involving a license, permit, or other entitlement for use pending before the agency if the officer has willfully or knowingly received a contribution in an amount of more than two hundred fifty dollars (\$250) within the preceding 12 months from a party or his or her agent, or from any participant, or his or her agent if the officer knows or has reason to know that the participant has a financial interest in the decision, as that term is described with respect to public officials in Article 1 (commencing with Section 87100) of Chapter 7.

If an officer receives a contribution which would otherwise require disqualification under this section, returns the contribution within 30 days from the time he or she knows, or should have known, about the contribution and the proceeding involving a license, permit, or other entitlement for use, he or she shall be permitted to participate in the proceeding.

(d) A party to a proceeding before an agency involving a license, permit, or other entitlement for use shall disclose on the record of the proceeding any contribution in an amount of more than two hundred fifty dollars (\$250) made within the preceding 12 months by the party, or his or her agent, to any officer of the agency. No party, or his or her agent, to a proceeding involving a license, permit, or other entitlement for use pending before any agency and no participant, or his or her agent, in the proceeding shall make a contribution of more than two hundred fifty dollars (\$250) to any officer of that agency during the proceeding and for three months following the date a final decision is rendered by the agency in the proceeding. When a closed corporation is a party to, or a participant in, a proceeding involving a license, permit, or other entitlement for use pending before an agency, the majority shareholder is subject to the disclosure and prohibition requirements specified in subdivisions (b), (c), and this subdivision.

(e) Nothing in this section shall be construed to imply that any contribution subject to being reported under this title shall not be so reported.

CALIFORNIA CODES  
GOVERNMENT CODE  
SECTION 87103

**87103.** A public official has a financial interest in a decision within the meaning of Section 87100 if it is reasonably foreseeable that the decision will have a material financial effect, distinguishable from its effect on the public generally, on the official, a member of his or her immediate family, or on any of the following:

(a) Any business entity in which the public official has a direct or indirect investment worth two thousand dollars (\$2,000) or more.

(b) Any real property in which the public official has a direct or indirect interest worth two thousand dollars (\$2,000) or more.

(c) Any source of income, except gifts or loans by a commercial lending institution made in the regular course of business on terms available to the public without regard to official status, aggregating five hundred dollars (\$500) or more in value provided or promised to, received by, the public official within 12 months prior to the time when the decision is made.

(d) Any business entity in which the public official is a director, officer, partner, trustee, employee, or holds any position of management.

(e) Any donor of, or any intermediary or agent for a donor of, a gift or gifts aggregating two hundred fifty dollars (\$250) or more in value provided to, received by, or promised to the public official within 12 months prior to the time when the decision is made. The amount of the value of gifts specified by this subdivision shall be adjusted biennially by the commission to equal the same amount determined by the commission pursuant to subdivision (f) of Section 89503.

For purposes of this section, indirect investment or interest means any investment or interest owned by the spouse or dependent child of a public official, by an agent on behalf of a public official, or by a business entity or trust in which the official, the official's agents, spouse, and dependent children own directly, indirectly, or beneficially a 10-percent interest or greater.

1 (Regulations of the Fair Political Practices Commission, Title 2, Division 6, California Code of  
2 Regulations.)

3 **§ 18438.5. Aggregated Contributions Under Section 84308.**

4 For purposes of Section 84308:

5 (a) Notwithstanding the provisions of Regulation 18215.1, to determine whether a  
6 contribution of more than \$250 has been made by any party to a proceeding, contributions made  
7 by a party's parent, subsidiary, or otherwise related business entity, (as those relationships are  
8 defined in subdivision (b) below), shall be aggregated and treated as if received from the party  
9 for purposes of the limitations and disclosure provisions of Section 84308.

10 (b) Parent, Subsidiary, Otherwise Related Business entity, defined.

11 (1) Parent-subsidiary. A parent-subsidiary relationship exists when one corporation has  
12 more than 50 percent of the voting power of another corporation.

13 (2) Otherwise related business entity. Business entities, including corporations,  
14 partnerships, joint ventures and any other organizations and enterprises operated for profit, which  
15 do not have a parent-subsidiary relationship are otherwise related if any one of the following  
16 three tests is met:

17 (A) One business entity has a controlling ownership interest in the other business entity.

18 (B) There is shared management and control between the entities. In determining whether  
19 there is shared management and control, consideration should be given to the following factors:

20 (i) The same person or substantially the same person owns and manages the two entities;

21 (ii) There are common or commingled funds or assets;

22 (iii) The business entities share the use of the same offices or employees, or otherwise  
23 share activities, resources or personnel on a regular basis;

1 (iv) There is otherwise a regular and close working relationship between the entities; or

2 (C) A controlling owner (50% or greater interest as a shareholder or as a general partner)

3 in one entity also is a controlling owner in the other entity.

4 Note: Authority cited: Section 83112, Government Code. Reference: Section 84308,

5 Government Code.

6 HISTORY

7 1. New section filed 5-26-2006; operative 6-25-2006. Submitted to OAL for filing pursuant to

8 *Fair Political Practices Commission v. Office of Administrative Law*, 3 Civil C010924,

9 California Court of Appeal, Third Appellate District, nonpublished decision, April 27, 1992

10 (FPPC regulations only subject to 1974 Administrative Procedure Act rulemaking requirements

11 and not subject to procedural or substantive review by OAL) (Register 2006, No. 21). For prior

12 history of section 18438.5, see Register 85, No. 8.

13 2. Amendment filed 8-12-2014; operative 9-11-2014 pursuant to title 2, section 18312(e)(1) of

14 the California Code of Regulations. Submitted to OAL for filing and printing pursuant to *Fair*

15 *Political Practices Commission v. Office of Administrative Law*, 3 Civil C010924, California

16 Court of Appeal, Third Appellate District, nonpublished decision, April 27, 1992 (FPPC

17 regulations only subject to 1974 Administrative Procedure Act rulemaking requirements and not

18 subject to procedural or substantive review by OAL) (Register 2014, No. 33).

19  
20  
21  
22  
23



**TO: San Bernardino International Airport Authority Commission**

**DATE: April 22, 2026**

**ITEM NO: 2a**

**PRESENTER: Michael Burrows, Chief Executive Officer**

**SUBJECT: INFORMATIONAL ITEMS – CHIEF EXECUTIVE OFFICER'S REPORT**

### **SUMMARY**

An oral report will be provided at the time of the meeting.

PREPARED BY:	Michelle Casey
CERTIFIED AS TO AVAILABILITY OF FUNDS:	N/A
APPROVED AS TO FORM AND LEGAL CONTENT:	Scott Huber
FINAL APPROVAL:	Michael Burrows

### **BACKGROUND INFORMATION**

None.

### **Attachments:**

1. None

	<p><b>TO: San Bernardino International Airport Authority Commission</b></p> <p><b>DATE: April 22, 2026</b></p> <p><b>ITEM NO: 2b</b></p> <p><b>PRESENTER: Mark Gibbs, Director of Aviation</b></p>
---	--

**SUBJECT: INFORMATIONAL ITEMS – REPORT ON GOOD NEIGHBOR PROGRAM**

**SUMMARY**

An oral report will be provided at the time of the meeting.

PREPARED BY:	Yajaira Maldonado
CERTIFIED AS TO AVAILABILITY OF FUNDS:	N/A
APPROVED AS TO FORM AND LEGAL CONTENT:	Scott Huber
FINAL APPROVAL:	Michael Burrows

**BACKGROUND INFORMATION**

None.

**Attachments:**

1. None

	<p><b>TO: San Bernardino International Airport Authority Commission</b></p> <p><b>DATE: April 22, 2026</b></p> <p><b>ITEM NO: 3</b></p> <p><b>PRESENTER: Mark Cousineau, Director of Finance</b></p>
---	--

**SUBJECT: REGISTER OF DEMANDS FOR MARCH 2026**

**SUMMARY**

SBIAA's Register of Demands for March 2026.

**RECOMMENDED ACTION(S)**

Receive for information.

**FISCAL IMPACT**

Various accounts as shown.

PREPARED BY:	Mark Cousineau
CERTIFIED AS TO AVAILABILITY OF FUNDS:	Mark Cousineau
APPROVED AS TO FORM AND LEGAL CONTENT:	N/A
FINAL APPROVAL:	Michael Burrows

**BACKGROUND INFORMATION**

The attached Register of Demands corresponds to checks issued in the month of March 2026. The total of the register is \$5,852,679.77.

**Fuel:** Titan Aviation Fuels was paid \$4,485,571.79 for aviation fuel to resell at Luxivair-SBD. Merit Oil Co. was paid \$41,375.78 to operate SBIAA vehicles and for resale at Luxivair-SBD.

**Utilities:** Burrtec Waste Industries Inc., City of San Bernardino Water Department, Frontier Communications Corporation, Granite Telecommunications, Southern California Edison, The Gas Company, Utility Telecom Group LLC, and Verizon were paid a total of \$117,430.22.

**Capital Projects Cost:** All American Building Services, Best Contracting Services Inc., and Geo Paving and Seal Coating were paid a total of \$71,480.25.

**Employee Benefits:** Kaiser Foundation Health Plan, Inc. and LegalShield were paid a total of \$62,276.67.

**Professional Services:** Aecom Technical Services Inc.; Allawos & Company; Aviatrix Communications LLC; Boston Fox Tigue International LLC; CJMC Holdings LLC; Coffman Associates Inc.; Cole Huber LLP; David Turch and Associates; Imagine Systems Inc.; Innovative Federal Strategies LLC; J.R. Miller & Associates Inc.; Jackhammer Movement Inc.; Joseph E. Bonadiman & Associates Inc.; Mead & Hunt; Mirau, Edwards, Cannon, Lewin, & Tooke LLP; Right Energy Group, and Tom Dodson & Associates were paid a total of \$466,340.62.

**Attachments:**

1. Register of Demands for the April 22, 2026 Commission Meeting
2. VISA breakdown - March 2026

**San Bernardino International Airport Authority**  
**Register of Demands for Commission Meeting**  
**4/22/2026**

Line	Company Name	Description	AP Register
1	A-Co Temporary Power, Inc	Power installation supplies and services	422.87
2	A.O. Reed & Co., LLC	Repairs and maintenance for HVAC system	17,372.88
3	Advexure LLC	Drones for SBIAA Ops department	7,617.26
4	Aecom Technical Services Inc.	Infrastructure consulting firm, design and professional services	218,341.43
5	All American Building Services	Terminal Lactation & Pet Relief Area Project	29,269.50
6	All Pro Broadcasting Inc.	Radio advertisement	7,600.00
7	Allawos & Company LLC	Consulting services for solar and green energy projects	7,000.00
8	Alliant Insurance Services Inc.	Insurance premium	1,000.00
9	Amazon Capital Services Inc.	Office supplies and equipment	6,170.41
10	Amtech Elevator Services	Elevator and escalator maintenance services	10,670.00
11	Arc Document Solutions, LLC	Document scanning services	698.18
12	Audacy Operations, LLC (Audacy Inc.)	Radio advertisement	41,954.98
13	Ava Peterson	Employee reimbursement	335.00
14	Aviatrix Communications LLC	Passenger services marketing support and management	71,635.07
15	B&H Photo & Electronics Corp	Office equipment and accessories	2,683.69
16	Belico Details LLC	Vehicle washes	600.00
17	Best Contracting Services Inc.	IAF roof repair	20,211.00
18	Blue Violet Networks	Solar power array for temporary surveillance system at new UAS	277.20
19	Boston Fox Tigue International LLC	Marketing services	22,861.90
20	BrightView Landscape Services, Inc.	Repairs and maintenance on irrigation system	1,460.01
21	Burrtec Waste Industries Inc.	Refuse	7,391.91
22	C & A Janitorial Services	Janitorial services	46,858.97
23	CALI939 KLLI-FM - KLLI Radio, LLC (KXOS Radio, LLC)	Radio advertisement	9,150.00
24	California Baptist University	Cal Baptist University Athletics Sponsorship	8,550.00
25	CED-Consolidated Electrical Distributors	Electrical supplies	807.28
26	Cintas Corporation	Uniform and mat rentals	9,249.98
27	City of San Bernardino	2025 State of the City Sponsorship - Gold Sponsor	125,160.49
28	City of San Bernardino Water Department	Water and sewer services	9,665.87
29	CJMC Holdings LLC	Construction and project management services for capital projects	3,000.00
30	Coffman Associates Inc.	Professional environmental services for SBIAA capital projects	500.00
31	Cole Huber LLP	Professional legal services	62,618.43
32	Control Concepts, Inc. (HSG, Inc.)	Maintenance and repairs on baggage handling system at the	1,657.75
33	Dave Graham	Employee reimbursement	320.00
34	David Turch and Associates	Federal legislative, advocacy and consulting services	5,000.00
35	Eagle Graphics LLC	Employee credit incentive for SBD online apparel store	10,927.03
36	Encore Lighting Inc.	Lighting supplies	1,190.91
37	Event Design Lab	Live streaming services	3,650.00
38	Ewing Outdoor Supply	Irrigation supplies and material	4,033.96
39	FedEx	Courier fees	320.49
40	Ferguson Enterprises LLC	Plumbing supplies and material	24.41
41	Ford Credit Company	Car lease payment	1,645.45
42	Frank's Fence & Supply Co., Inc.	Fencing material and supplies	1,850.00
43	Frontier Communications Corporation	Telephone services	5,605.38
44	Geo Paving and Seal Coating	Street improvements and repairs	21,999.75
45	GMSTEK LLC	Monthly fuel management and point-of-sale software	2,319.93
46	Granite Telecommunications	Telephone services	4,375.83
47	Harbour Productions	Production fees for Cruising at Altitude concert	532.36
48	Imagine Systems Inc.	IT consulting services and desktop maintenance	3,768.56
49	Ink'd Promo and Apparel	Promotional products and apparel	10,909.42
50	Inland Empire Broadcasting Corp DBA KOLA-FM Radio	Radio advertisement	2,800.00
51	Inland Empire Economic Partnership	Sponsorship for E-Commerce and Logistics Summit	7,500.00



**March 2026**

**SBIAA**

<b>Line</b>	<b>Description</b>	<b>Vendor</b>	<b>Dept.</b>	<b>Amount</b>
1	Membership dues	California Special Districts Association	Administration	2,381.00
2	Employee engagement for holiday activities	Cookie Co	Administration	832.64
3	Floral arrangement for condolences	1-800-Flowers	Administration	173.98
4	Water	Sam's Club	Maintenance	59.80
5	Stop signs	Uline	Maintenance	507.09
6	BAU caps for the new Security Identification Display Area line	Frank's Fence & Supply	Maintenance	47.85
7	Lunch for emergency exercise tabletop	Panera Bread	Airport Operations	2,819.98
8	Beverages for emergency exercise tabletop	Stater Bros	Airport Operations	94.84
9	Food for meeting	Chick-fil-A	Airport Operations	188.86
10	Lunch - Waba Grill for interviews	Doordash	Airport Operations	64.46
11	Wildlife K-9 collar and tag	The Dog Outdoors	Airport Operations	52.51
12	UAS model training	FAA Drone Zone	Airport Operations	5.00
13	K-9 health exam and vaccinations	Redlands Animal Hospital	Airport Operations	153.61
14	Registration for JumpStart Airport Development Conference in Chicago, IL	Airports Council	Aviation	1,365.00
15	Registration for Terrell Bowie for ISC West conference in Las Vegas, NV March 2026	RX USA	Badging Office	1,300.00
16	Lodging for Y.Maldonado for CMCA class in San Marcos, CA - 57801, E100, D15000	Fairfield Inn & Suites	Clerk of the Board	612.68
17	Hospitality for Vanir meeting	Panera Bread	Executive Office	201.99
18	Incidental - E-Visa for Routes Americas conference in Brazil	VFS Services	Executive Office	80.90
19	Airfare - Routes Americas air development conference	United Airlines	Executive Office	291.60
20	Airfare - Inland Action Washington legislation meetings	United Airlines	Executive Office	768.35
21	Capacitor	Allied Refrigeration Inc.	Facilities	11.79
22	Breakers	EDC Electrical Distribution & Controls	Facilities	949.88
23	Tools and supplies for facilities	Home Depot	Facilities	142.84
24	Pump	Home Depot	Facilities	334.93
25	Badge reader holders	Markertek Video Supply	Facilities	240.95
26	Tools and supplies for facilities	Lowe's	Facilities	26.38
27	Tools and supplies for facilities	Lowe's	Facilities	75.40
28	Tools and supplies for facilities	Channellock	Facilities	68.65
29	Door hinges	BSA Security Integrators	Facilities	92.84
30	Tools and supplies for facilities	Lowe's	Facilities	35.43
31	Light bulbs	Lumina Lighting	Facilities	51.20
32	Refund for parts purchased	Ebay	Facilities	(326.25)
33	Jockey Pump	Absolute Suppliers	Facilities	1,738.84
34	Refund for parts purchased	Online Power Products	Facilities	(700.57)
35	Drill Bit	Home Depot	Facilities	95.63
36	2-way joystick	Ebay	Facilities	536.96
37	Power cords	Home Depot	Facilities	50.14
38	SBIAA gas service	SoCal Gas Co.	Finance	1,001.50
39	SBIAA gas service	SoCal Gas Co.	Finance	1,001.50
40	Tax filing fee	TaxBandits	Finance	1.85
41	Tax filing fee	TaxBandits	Finance	9.25
42	Finance software license	Target	Finance	1,995.00
43	Tax filing fee	TaxBandits	Finance	4.33
44	Tax filing fee	TaxBandits	Finance	142.77
45	Fleet shop hand dolly tires	Pete's Road Service	Fleet	105.73
46	Coolant system pressure tester	Snap-on	Fleet	567.65
47	Specialty fuse for ARFF truck R14	Waytek	Fleet	28.01
48	Winged plastic mount head for fleet shop tire machine replacement part	Hunter Engineering	Fleet	92.58
49	Connector and seal	Velocity Truck Centers	Fleet	77.10
50	Smog for agency vehicles 2025	Affordable Auto Service	Fleet	690.00
51	Pick up and disposal of used tires	Pete's Road Service	Fleet	816.50
52	Tires for Ford Escape, Building 48 - 100480, D52330	Pete's Road Service	Fleet	872.65
53	Ball valve	Grainger	Fleet	207.46
54	Specialty fuse for ARFF truck R14	Waytek	Fleet	28.01
55	Rotary tool	Home Depot	Grounds	162.04
56	Paint for curbs and bollards at #339	K&L Hardware	Grounds	211.20
57	Ball valve	Backflow Parts USA	Grounds	320.59

**March 2026**

**SBIAA**

<b>Line</b>	<b>Description</b>	<b>Vendor</b>	<b>Dept.</b>	<b>Amount</b>
58	Tools and toolbox	Home Depot	Grounds	254.44
59	Chain link fencing for new SIDA line	Frank's Fence & Supply	Grounds	995.06
60	Fencing material for new SIDA line fencing	Frank's Fence & Supply	Grounds	126.15
61	Shopvac to replace old one	Zoro Tools	Grounds	595.96
62	Silicone sealant for airfield repairs	M&M ASM	Grounds	591.00
63	Paint for bollards at gate#10	K&L Hardware	Grounds	237.66
64	Paint for fencing at new SIDA line	K&L Hardware	Grounds	78.38
65	Pavement reflectors for hydrants along runway	Insite Solutions	Grounds	181.46
66	Broom for Grounds' office	Home Depot	Grounds	17.37
67	Paint for bollards at gate #10	Home Depot	Grounds	84.56
68	Squirrel bait	Nutrien Ag Solutions	Grounds	126.60
69	Diamond cup wheel	Home Depot	Grounds	108.72
70	Courier fees	The UPS Store	Human Resources	20.59
71	Employee wellness, fit for duty exam	SCEM Urgent Care	Human Resources	82.40
72	Agencies' website usage charges, \$187.40 split between servers for each agency	DigitalOcean	IT Department	93.70
73	Website management software, \$107.98 split between servers for each agency. IVDA (57331 D54000 E110)	CPANEL	IT Department	53.99
74	DNS service for .gov domains	Amazon Web Services	IT Department	1.02
75	Domain name renewal	Network Solutions	IT Department	389.73
76	Subscription for cloud storage for Apple device	Apple.com	IT Department	0.99
77	Microsoft Office 365 monthly subscription	Microsoft	IT Department	81.90
78	Website monitoring service	OH DEAR LIER	IT Department	29.87
79	Light for North SIDA line access control	Wolf Automation	IT Department	644.23
80	Hosted IT collaboration	Slack	IT Department	43.75
81	Domain name renewal	Network Solutions	IT Department	131.94
82	Terminal background music streaming service	Soundtrack Your Brand	IT Department	60.00
83	TV content streaming service for concourse cafÃ©	Sling	IT Department	66.79
84	Microsoft Teams audio monthly subscription	Microsoft	IT Department	2.63
85	Microsoft Office 365 monthly subscription	Microsoft	IT Department	680.40
86	Processing fee for parking lot transactions	Windcave	IT Department	305.00
87	CBP TV Content streaming service	Dish Network	IT Department	119.73
88	Website management software, \$107.98 split between servers for each agency.	CPANEL	IT Department	53.99
89	Agencies' website usage charges, \$187.40 split between servers for each agency IVDA (57331 D54000 E110)	DigitalOcean	IT Department	93.70
90	Fuel for crew car	Chevron	Luxivair-SBD	40.62
91	Fuel for crew car	Chevron	Luxivair-SBD	25.64
92	Hospitality bar restock	Sam's Club	Luxivair-SBD	117.35
93	Hospitality bar restock	Sam's Club	Luxivair-SBD	141.74
94	Valentine's theme decor	Ruth's Roses	Luxivair-SBD	77.83
95	Hospitality bar restock	Sam's Club	Luxivair-SBD	574.08
96	Hospitality bar restock	Sam's Club	Luxivair-SBD	171.86
97	Movie streaming for FBO theater	Netflix	Luxivair-SBD	24.99
98	Training for Line Tech - Z.Carlson	NATA	Luxivair-SBD	725.00
99	Cable for FBO lobby	Dish Network	Luxivair-SBD	161.37
100	Airfare for W.McConaughey, NBAA Conference in Las Vegas, NV	American Airlines	Luxivair-SBD	992.10
101	Subscription for cloud storage for Apple device	Apple	Luxivair-SBD	0.99
102	Inventory for Leland's Coffee	Sam's Club	Luxivair-SBD	31.94
103	Hospitality for DHS event	Donut Hut	Luxivair-SBD	26.50
104	Inventory for Leland's Coffee	Sam's Club	Luxivair-SBD	27.78
105	Baggage fee for AirCargo Conference travel	Southwest Airlines	Luxivair-SBD	35.00
106	Ground transportation for AirCargo Conference in Orlando, FL	Uber	Luxivair-SBD	112.01
107	Ground transportation for AirCargo Conference in Orlando, FL	Uber	Luxivair-SBD	15.00
108	Airfare for Z.Carlson for NATA training course in Ft. Meyers, FL March 2026	American Airlines	Luxivair-SBD	796.00
109	Lav dump head replacement	Aero Specialties	Luxivair-SBD	274.08
110	Lav dump head rebuild kit	Aero Specialties	Luxivair-SBD	38.58
111	Airfare - Seat upgrade for Z.Carlson for NATA training course in Ft. Meyers, FL Mar. 2026 (see memo)	American Airlines	Luxivair-SBD	152.54

**March 2026**

**SBIAA**

<b>Line</b>	<b>Description</b>	<b>Vendor</b>	<b>Dept.</b>	<b>Amount</b>
112	Airfare for R.Fajardo for NATA training course in Ft. Meyers, FL March 2026	American Airlines	Luxivair-SBD	671.75
113	Lodging for W.McConaughey for AirCargo Conference	Omni Hotel	Luxivair-SBD	1,090.05
114	Inventory for Leland's Coffee	Costco	Luxivair-SBD	163.67
115	Baggage fee for AirCargo Conference travel	Southwest Airlines	Luxivair-SBD	35.00
116	Tail lights FBO fuel trucks	FleetPride	Luxivair-SBD	144.04
117	Tail lights FBO fuel trucks	Fleetpride	Luxivair-SBD	144.04
118	Airfare - seat upgrades for second seat booked for Zachary Carlson's NATA training course in Ft. Meyers, FL (see memo)	American Airlines	Luxivair-SBD	396.29
119	Airfare for second seat booked for Z.Carlson's NATA training course in Ft. Meyers, FL (see memo)	American Airlines	Luxivair-SBD	707.40
120	FBO fuel trucks brake light replacements	Polar Service Centers	Luxivair-SBD	390.94
121	FBO GPU tires	Pete's Road Service	Luxivair-SBD	870.34
122	Brake controller module for fbo blue golf cart	Golf Cars of Riverside	Luxivair-SBD	196.84
123	Def header for FBO fuel truck	Engine Accessory Manufacturing	Luxivair-SBD	952.13
124	Promotional giveaway for NBAA event	Michael Kors	Luxivair-SBD	470.04
125	Floral arrangements for 2/12 meeting at IAF	Bouquet Florist	Luxivair-SBD	304.28
126	Rentals for 2/12 meeting at IAF	Party All the Time	Luxivair-SBD	261.00
127	Valentine's themed hospitality	Dollar Tree	Luxivair-SBD	20.76
128	Valentine's theme decor	Family Follar	Luxivair-SBD	26.64
129	Valentine's theme decor	Dollar General	Luxivair-SBD	41.43
130	Radio battery replacement	Airwave Communication	Luxivair-SBD	151.48
131	Hospitality bar restock	Sam's Club	Luxivair-SBD	189.80
132	Point of sale for Leland's Coffee	EposNow	Luxivair-SBD	470.00
133	Leland's coffee permit renewal	Enviormental Health Services	Luxivair-SBD	646.57
134	Laundry detergent	Stater Bros	Luxivair-SBD	14.00
135	Ramp saftey supplies	Traffic Cones For Less	Luxivair-SBD	842.74
136	Airfare for M.Martinez, NBAA Conference in Las Vegas, NV	American Airlines	Luxivair-SBD	992.10
137	Hospitality bar restock	Sam's Club	Luxivair-SBD	187.15
138	Airfare for A.Peterson, NBAA Conference in Las Vegas, NV	American Ailines	Luxivair-SBD	922.47
139	Car wash for crew car	Quick Quack Carwash	Luxivair-SBD	12.99
140	Car wash for crew car	Quick Quack Carwash	Luxivair-SBD	26.04
141	Promotional giveaway for National Pizza Day	Domino's Pizza	Luxivair-SBD	142.10
142	Lunch - Amber Travel	Chik Fil A	Marketing	22.95
143	Candy for giveaways in support of passenger service promo	Walmart	Marketing	45.01
144	Annual subscription for Adobe Creative Cloud Pro	Adobe	Marketing	2,399.76
145	Annual corporate memebership	LA Air Cargo	Marketing	500.00
146	Electricity service at AirCargo 2026	Pinnacle	Marketing	493.04
147	Stockphoto imagery credit	Adobe	Marketing	49.99
148	Vehicle parking for AirCargo 2026 Travel	OIAA Parking	Marketing	126.00
149	Baggage fee for AirCargo Conference travel	Southwest Airlines	Marketing	80.00
150	Transporation from MCO to Hotel	Uber	Marketing	123.89
151	Materials Handling Fees	Audie Expo	Marketing	162.74
152	Service fee for shipping from hotel to SBD	11th Hour Business Center	Marketing	25.00
153	Hotel for Air Cargo 2026	Omni Hotels	Marketing	1,095.78
154	Baggage Fees	Southwest Airlines	Marketing	80.00
155	Voucher winner Gergory Weissman and his companion	Breeze Airways	Marketing	997.98
156	Lunch - Amber Travel	Omni Orlando	Marketing	23.43
157	Custom branded stickers in support of SBD marketing	Canva	Marketing	179.98
158	Custom branded luggage tags in support of SBD marketing	4imprint	Marketing	849.38
159	Custom branded stickers in support of Leland's Coffee	Sticker App	Marketing	258.83
160	Candy for giveaways in support of passenger service promo	Smart & Final	Marketing	56.90
161	""Travel More"" SBD stickers	Sticker App	Marketing	400.20
162	Hospitality for agency event	Costco	Security	64.33
163	Training on aviation security and FAA operations/procedures for 3 office	City of Ontario	Security	385.88
164	Supplies for projects	Lowe's	Terminals	16.64
165	Charging point signage for terminal	Xgraphix	Terminals	169.72
166	Registration for Airport Customer Experience Symposium	American Association of Airport Executives	Terminals	1,375.00
167	Thumb tacks	Walmart	Terminals	12.44
168	Airfare - D.Graham: AAAE conference in San Jose, CA April 2026	Southwest Airlines	Terminals	338.81

March 2026

SBIAA

Line	Description	Vendor	Dept.	Amount
169	SBIAA gas service	SoCal Gas Co.	Terminals	1,001.50
170	SBIAA gas service	SoCal Gas Co.	Terminals	57.59
171	Load lugs for terminal video wall	EDC Electrical Distribution & Controls	Terminals	533.16
				58,089.62
	VISA Statement Balance			58,089.62
	Date Prepared: 4/22/2026			

	<p><b>TO: San Bernardino International Airport Authority Commission</b></p> <p><b>DATE: April 22, 2026</b></p> <p><b>ITEM NO: 4</b></p> <p><b>PRESENTER: Mark Cousineau, Director of Finance</b></p>
---	--

**SUBJECT: RECEIVE AND FILE TREASURER'S REPORT FOR FEBRUARY 28, 2026 FOR THE SAN BERNARDINO INTERNATIONAL AIRPORT AUTHORITY (SBIAA)**

**SUMMARY**

SBIAA's monthly Treasurer's Report that reconciles cash.

**RECOMMENDED ACTION(S)**

Receive and file Treasurer's Report for February 28, 2026 for the San Bernardino International Airport Authority (SBIAA).

**FISCAL IMPACT**

None.

PREPARED BY:	Mark Cousineau
CERTIFIED AS TO AVAILABILITY OF FUNDS:	N/A
APPROVED AS TO FORM AND LEGAL CONTENT:	N/A
FINAL APPROVAL:	Michael Burrows

**BACKGROUND INFORMATION**

Attached is the Treasurer's Report for February 28, 2026, for the San Bernardino International Airport Authority. The total book value of cash accounts is \$4,754,089.76 on February 28, 2026. Bank statements reflect \$4,808,081.27. The difference between the two numbers is related to the outstanding checks, the deposits in transit, and other items February 28, 2026.

If you have any questions about this report, please contact me at (909) 382-4100 x141.

**Attachments:**

1. Treasurer's Report for February 28, 2026

**SAN BERNARDINO INTERNATIONAL AIRPORT AUTHORITY**  
**Treasurer Report**  
**February 28, 2026**

<u>Cash</u>	Balance 01/31/26	Activities	Balance 02/28/26
<i>Checking Account - Wells Fargo Bank</i>	\$ 3,015,042.94	\$ (714,873.69)	\$ 2,300,169.25
Deposits In Transit:			
Beginning	60.00	(60.00)	-
Ending		195.00	195.00
Outstanding Checks:			
Beginning	(376,371.56)	376,371.56	-
Ending		(54,186.51)	(54,186.51)
<i>Premium Money Market Account - Wells Fargo Bank</i>	800,647.39	294.86	800,942.25
Deposits In Transit:			
Beginning			
Ending			
<i>Payroll Account - Wells Fargo Bank</i>	-	-	-
Outstanding Checks:			
Beginning	-	-	-
Ending	-	-	-
Subtotal	3,439,378.77	(392,258.78)	3,047,119.99
<u>Investments</u>			
<i>Local Agency Investment Funds</i>	364,430.40	-	364,430.40
Deposits In Transit:			
Beginning			
Ending			
Subtotal	364,430.40	-	364,430.40
<u>Investments Held With Fiscal Agent</u>			
Debt Service Fund-US Bank-2021A series	547,987.47	104,347.48	652,334.95
Reserve Fund- US Bank 2021A series	542,930.75	1,530.18	544,460.93
Debt Service Fund-US Bank-2021B series	60,393.16	16,486.85	76,880.01
Reserve Fund -US Bank-2021B series	68,669.94	193.54	68,863.48
Subtotal	1,219,981.32	122,558.05	1,342,539.37
Total Cash and Investments	\$ 5,023,790.49	(269,700.73)	\$ 4,754,089.76

I certify that this report accurately reflects all cash and investments for the above period and all the investment is in compliance with San Bernardino International Airport Authority's Investment policy. San Bernardino International Airport Authority shall be able to meet its expenditure requirement for next six month, anticipating operational fund receipts from IVDA.

  
 Mark Cousineau, Treasurer

	<p><b>TO: San Bernardino International Airport Authority Commission</b></p> <p><b>DATE: April 22, 2026</b></p> <p><b>ITEM NO: 5</b></p> <p><b>PRESENTER: Jeff Barrow, Director of Development</b></p>
---	---

**SUBJECT: AUTHORIZE STAFF TO ADVERTISE THE GENERAL AVIATION PARKING REDESIGN PROJECT**

**SUMMARY**

Approval of this item would authorize staff to advertise a Notice Inviting Bids for the General Aviation Parking Redesign Project. The authorized scope of work for this project provides for the redesign of the general aviation parking area. This project will be procured in accordance with the agency's policies and procedures.

**RECOMMENDED ACTION(S)**

Authorize staff to advertise for the General Aviation Parking Redesign Project in accordance with the agency's policies and procedures.

**FISCAL IMPACT**

None at this time. This item is for authorization to publicly advertise and solicit construction bids for the General Aviation Parking Redesign Project only.

PREPARED BY:	Griselda Lizarraga
CERTIFIED AS TO AVAILABILITY OF FUNDS:	N/A
APPROVED AS TO FORM AND LEGAL CONTENT:	Scott Huber
FINAL APPROVAL:	Michael Burrows

**BACKGROUND INFORMATION**

The proposed project includes new pavement striping for small aircraft parking areas, installation and striping of new helicopter pads, removal of existing aircraft tie-downs, pavement repairs, and installation of new aircraft tie-downs. Additionally, all pavement markings within the project limits will be repainted to improve visibility and overall surface condition. The project will increase aircraft parking capacity and improve operational safety and landing conditions for arriving aircraft. This project supports SBIAA's continued commitment to maintaining safe, efficient, and high-quality airfield facilities for tenants and airfield users.

Approval of the above recommended action will provide the necessary authorization for staff to advertise bids for the work described. Following receipt and review of bids, the lowest responsible bid will be brought back to the SBIAA Commission for consideration and approval.

Staff recommends the Commission approve the above recommended action.

**Attachments:**

1. Site Map
2. Project Plans

# SITE MAP



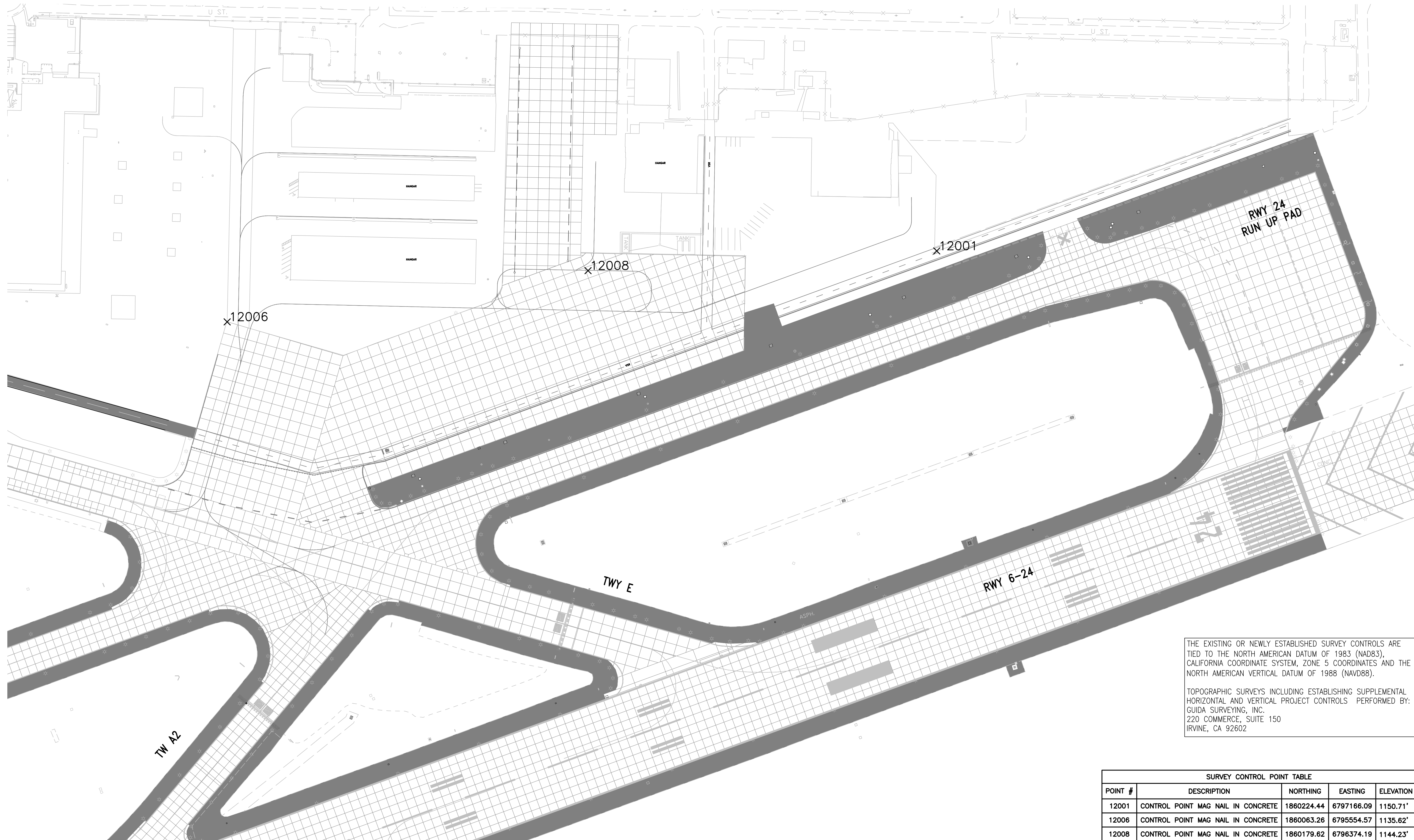

THE EXISTING OR NEWLY ESTABLISHED SURVEY CONTROLS ARE TIED TO THE NORTH AMERICAN DATUM OF 1983 (NAD83), CALIFORNIA COORDINATE SYSTEM, ZONE 5 COORDINATES AND THE NORTH AMERICAN VERTICAL DATUM OF 1988 (NAVD88).

TOPOGRAPHIC SURVEYS INCLUDING ESTABLISHING SUPPLEMENTAL HORIZONTAL AND VERTICAL PROJECT CONTROLS PERFORMED BY: GUIDA SURVEYING, INC. 220 COMMERCE, SUITE 150 IRVINE, CA 92602

SURVEY CONTROL POINT TABLE				
POINT #	DESCRIPTION	NORTHING	EASTING	ELEVATION
12001	CONTROL POINT MAG NAIL IN CONCRETE	1860224.44	6797166.09	1150.71'
12006	CONTROL POINT MAG NAIL IN CONCRETE	1860063.26	6795554.57	1135.62'
12008	CONTROL POINT MAG NAIL IN CONCRETE	1860179.62	6796374.19	1144.23'

MARK	REVISIONS	BY	APPR.	DATE
	FOR CONSTRUCTION	RL	JB	03-24-26



PREPARED BY  
**AECOM**  
 AECOM  
 999 TOWN & COUNTRY ROAD  
 ORANGE, CALIFORNIA 92668  
 T: 714.567.2400  
 F: 714.567.2729  
 www.aecom.com



SAN BERNARDINO INTERNATIONAL AIRPORT AUTHORITY  
 APPROVED BY: *[Signature]* 03/24/26  
 DATE  
 APPROVED BY: \_\_\_\_\_ DATE

SAN BERNARDINO INTERNATIONAL AIRPORT  
**GA RAMP  
 PARKING RE-DESIGN  
 SURVEY CONTROL**

DATE  
 03/24/26  
 DRAWING NUMBER  
 CD-001  
 SHEET NUMBER  
 1 OF 5

FOR REFERENCE

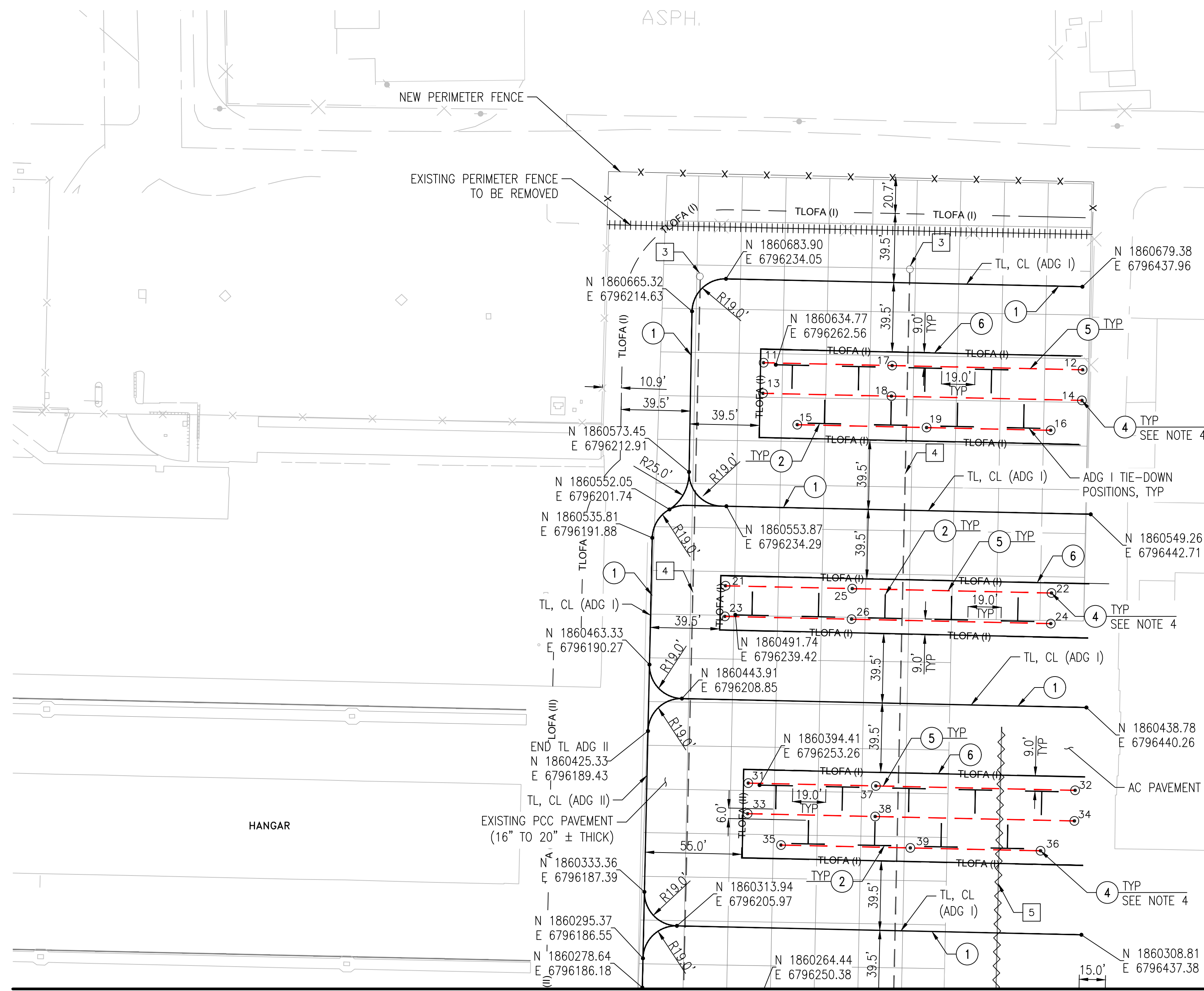

TIEDOWN ANCHOR POINT TABLE			
POINT #	NORTHING	EASTING	DESCRIPTION
11	1860635.9216	6796255.5806	TIEDOWN ANCHOR - TYPE II
12	1860631.8797	6796438.0362	TIEDOWN ANCHOR - TYPE II
13	1860618.4259	6796255.1930	TIEDOWN ANCHOR - TYPE II
14	1860614.3839	6796437.6486	TIEDOWN ANCHOR - TYPE II
15	1860600.4872	6796274.8006	TIEDOWN ANCHOR - TYPE II
16	1860597.2758	6796419.7653	TIEDOWN ANCHOR - TYPE II
17	1860634.2938	6796329.0627	TIEDOWN ANCHOR - TYPE III
18	1860616.7980	6796328.6752	TIEDOWN ANCHOR - TYPE III
19	1860598.8482	6796348.7826	TIEDOWN ANCHOR - TYPE III
21	1860508.3728	6796233.7823	TIEDOWN ANCHOR - TYPE II
22	1860504.2423	6796420.2370	TIEDOWN ANCHOR - TYPE II
23	1860490.8771	6796233.3947	TIEDOWN ANCHOR - TYPE II
24	1860486.7466	6796419.8494	TIEDOWN ANCHOR - TYPE II
25	1860506.7671	6796306.2647	TIEDOWN ANCHOR - TYPE III
26	1860489.2714	6796305.8771	TIEDOWN ANCHOR - TYPE III
31	1860395.5569	6796246.7870	TIEDOWN ANCHOR - TYPE II
32	1860391.4153	6796433.7415	TIEDOWN ANCHOR - TYPE II
33	1860378.0612	6796246.3994	TIEDOWN ANCHOR - TYPE II
34	1860373.9196	6796433.3539	TIEDOWN ANCHOR - TYPE II
35	1860360.1336	6796265.5071	TIEDOWN ANCHOR - TYPE II
36	1860356.8447	6796413.9709	TIEDOWN ANCHOR - TYPE II
37	1860393.9401	6796319.7692	TIEDOWN ANCHOR - TYPE III
38	1860376.4444	6796319.3816	TIEDOWN ANCHOR - TYPE III
39	1860358.4946	6796339.4891	TIEDOWN ANCHOR - TYPE III

**CONSTRUCTION NOTES:**

- ① PAINT 6" WIDE YELLOW TAXILANE CENTERLINE MARKING, PER DETAIL 1/CD-101.
- ② PAINT 6" WHITE AIRCRAFT TIE-DOWN POSITION MARKING, PER DETAIL 2/CD-101.
- ③ PAINT YELLOW HELICOPTER PARKING POSITION, PER DETAIL 3/CD-102.
- ④ INSTALL TIE-DOWN ANCHOR (ADG I) PER DETAIL 2/CD-202.
- ⑤ INSTALL TIE-DOWN ANCHOR CABLE ASSEMBLY PER DETAIL 2/CD-202.
- ⑥ PAINT 6" WIDE WHITE TLOFA MARKING, PER DETAIL 3/CD-101.

**DEMOLITION/DISPOSITION NOTES:**

- 1 PROTECT IN PLACE (ITEM AS SHOWN).
- 2 REMOVE AIRCRAFT TIE-DOWN WITH CONCRETE CAP AND REPAIR CONCRETE PAVEMENT PER DETAIL 3/CD-202.
- 3 REMOVE AIRCRAFT TIE-DOWN AND REPAIR CONCRETE PAVEMENT PER DETAIL 3/CD-202.
- 4 REMOVE AIRCRAFT TIE-DOWN ANCHOR ASSEMBLY.
- 5 OBLITERATE EXISTING PAVEMENT MARKINGS.

**GENERAL NOTES:**

- 1. CONTRACTOR SHALL PROTECT IN PLACE ALL EXISTING AIRFIELD LIGHTS, UTILITIES, AND STRUCTURES.
- 2. UNDERGROUND UTILITIES SHOWN ARE APPROXIMATE AND ARE BASED ON RECORD DRAWINGS. CONTRACTOR SHALL INVESTIGATE AND VERIFY UTILITIES BEFORE PROCEEDING WITH WORK.
- 3. ALL ITEMS TO REMAIN THAT ARE DAMAGED DURING WORK, SHALL BE REPLACED, REPAIRED OR RESTORED TO ITS ORIGINAL CONDITION AT NO COST TO THE OWNER.
- 4. TIE-DOWN ANCHORS SHALL MAINTAIN MINIMUM 3' O.C. TO ANY CONCRETE JOINT, TYP.
- 5. COORDINATES ARE BASED ON THE EXISTING SURVEY POINTS SHOWN ON DWG CD-001. PRIOR TO PAINTING AND INSTALLING THE TIE-DOWN ANCHORS, THE CONTRACTOR SHALL FIELD-VERIFY THE COORDINATES AGAINST THE DIMENSIONS AND REPORT ANY DISCREPANCIES TO THE ENGINEER.
- 6. THIS DRAWING SHALL BE VIEWED & PRINTED IN COLOR.

**STRIPING GENERAL NOTES:**

- 1. CONTRACTOR SHALL RESTORE ALL STRIPING OUTSIDE IMPROVEMENT AREAS, DAMAGED BY CONSTRUCTION, TO ORIGINAL CLARITY. THIS MAY REQUIRE RESTRIPING OF THE MARKING TO THE NEXT ANGLE POINT OR AS DIRECTED BY THE RESIDENT ENGINEER.
- 2. ALL NEW PAVEMENT MARKINGS SHALL BE PAINTED WITH 6" WIDE BLACK BORDERS, UNLESS NOTED OTHERWISE OR DIRECTED BY THE RESIDENT ENGINEER. DIMENSIONS SHOWN EXCLUDE BORDER.
- 3. UNLESS OTHERWISE NOTED, ALL PERMANENT PAVEMENT MARKINGS SHALL RECEIVE GLASS BEADS. EXCEPT FOR BLACK BORDERS.
- 4. REFRESH/REPAINT OF EXISTING PAVEMENT MARKINGS SHALL BE FOR THE ENTIRETY OF THE MARKING. PARTIAL REFRESH/REPAINT OF EXISTING MARKINGS IS NOT ACCEPTABLE.

**LEGEND:**

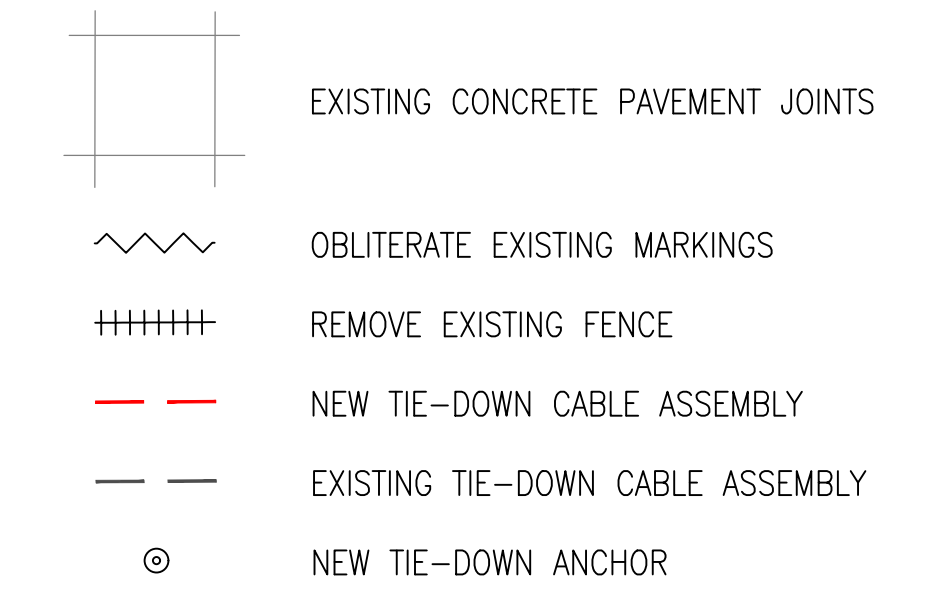

MATCHLINE - SEE DWG No CD-102

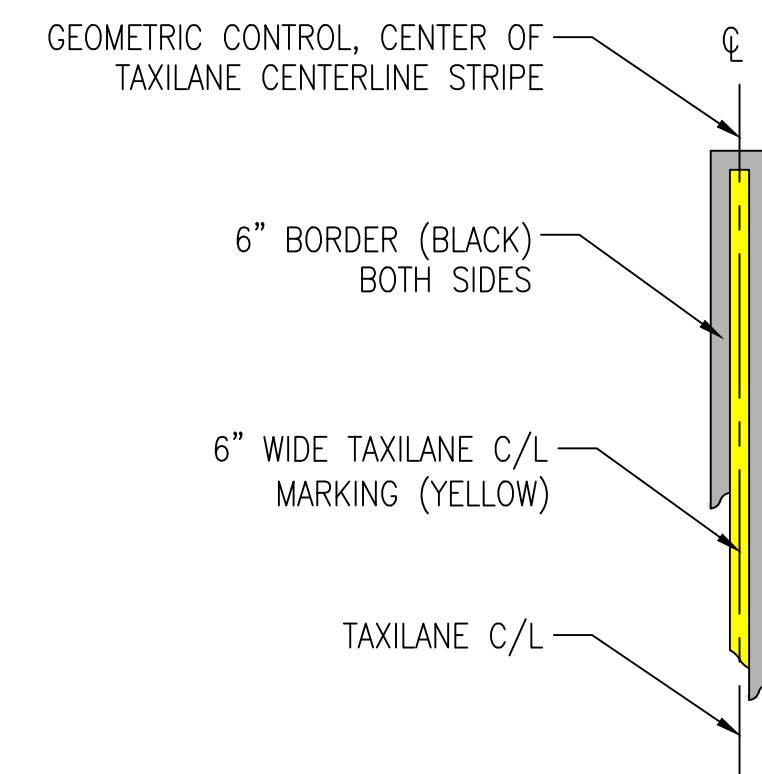

① TAXILANE CENTERLINE MARKING  
NOT TO SCALE

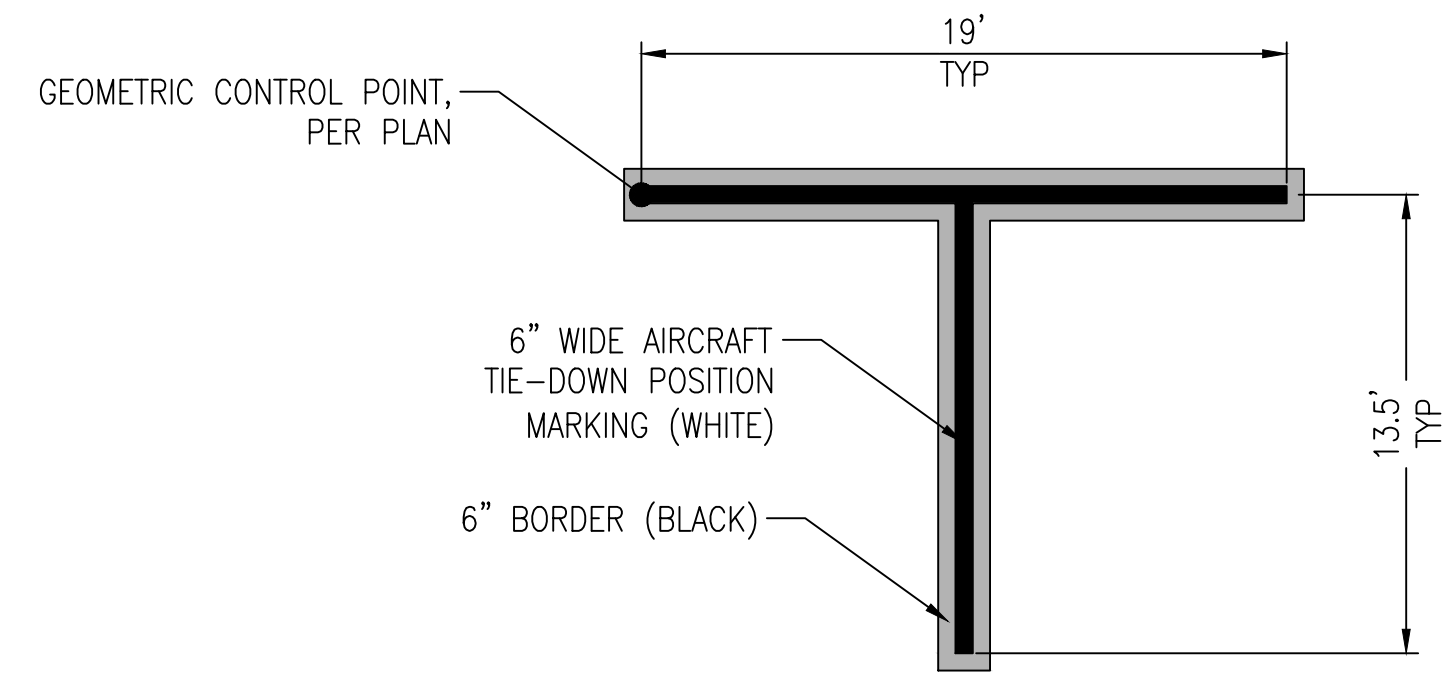

② TIE-DOWN POSITION MARKING  
NOT TO SCALE

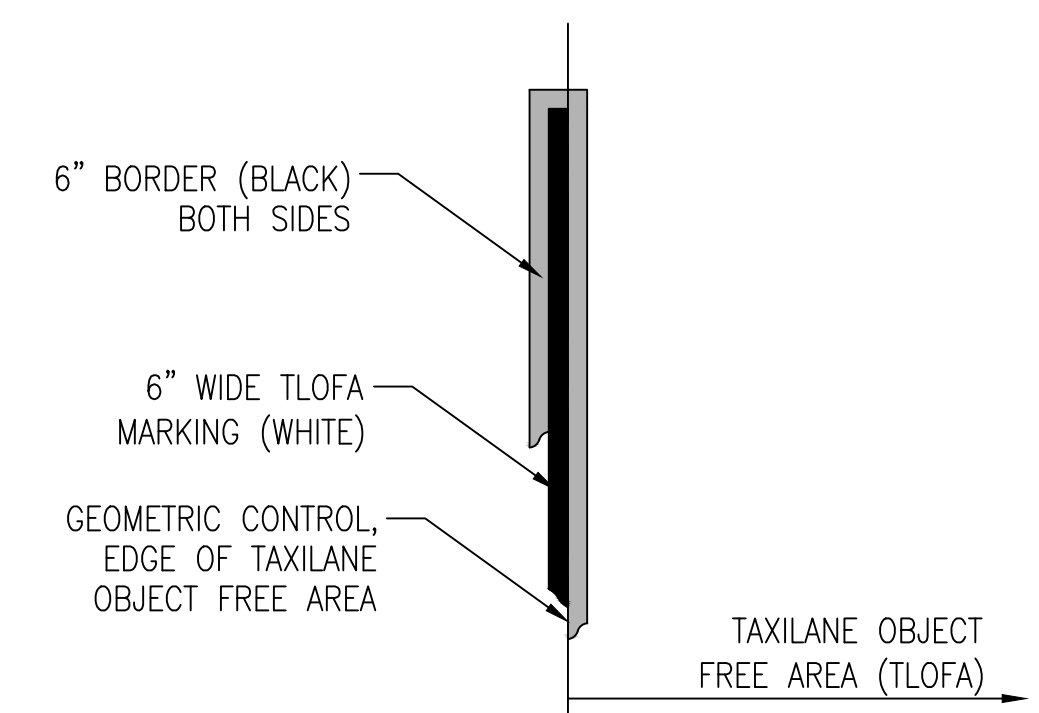

③ TAXILANE OBJECT FREE AREA MARKING  
NOT TO SCALE

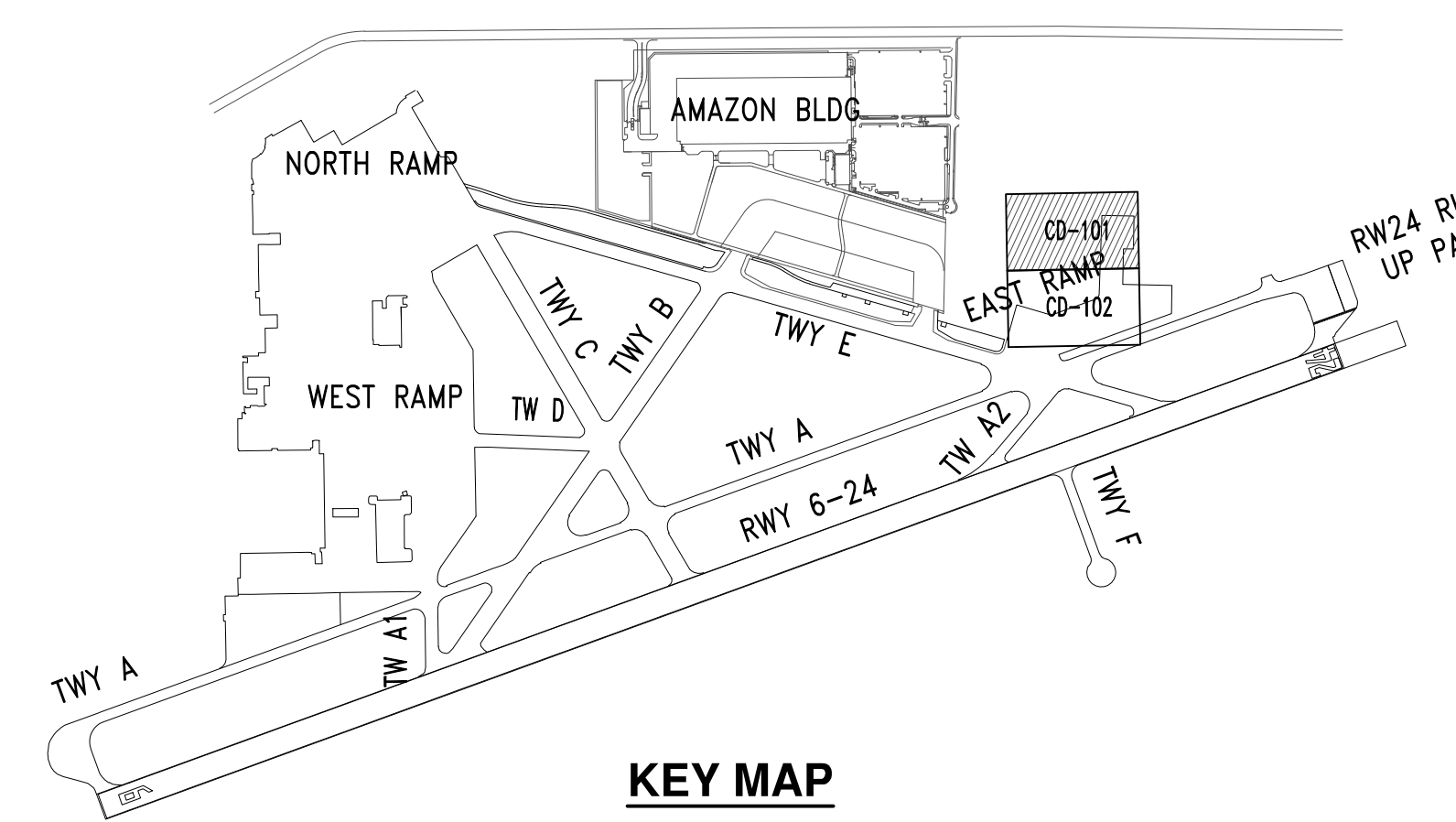

KEY MAP

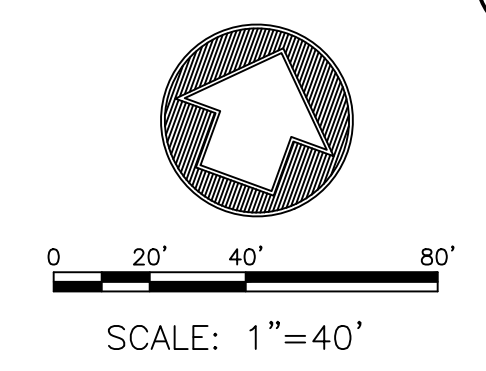

MARK	REVISIONS	BY	APPR.	DATE
	FOR CONSTRUCTION	RL	JB	03-24-26



PREPARED BY  
**AECOM**  
AECOM  
999 TOWN & COUNTRY ROAD  
ORANGE, CALIFORNIA 92668  
T: 714.567.2400  
F: 714.567.2729  
www.aecom.com



SAN BERNARDINO INTERNATIONAL AIRPORT AUTHORITY  
APPROVED BY: *[Signature]* 03/24/26  
DATE

SAN BERNARDINO INTERNATIONAL AIRPORT		DATE
GA RAMP PARKING RE-DESIGN GA MARKINGS REDESIGN, SHEET 1 OF 2		03/24/26
		DRAWING NUMBER
		CD-101
		SHEET NUMBER
		2 OF 5

DWG Name: C:\Users\gallardo\Box\60738461\_SBD Shldr Slurry and Paint\900\_CAD\_GIS\910\_CAD\_Working\AG\_CD-101-TO-CD-103\_GA\_Ramp\_RL.dwg  
 User: gallardo  
 Date: Mar 24, 2026 10:26am

MATCHLINE - SEE DWG No CD-101

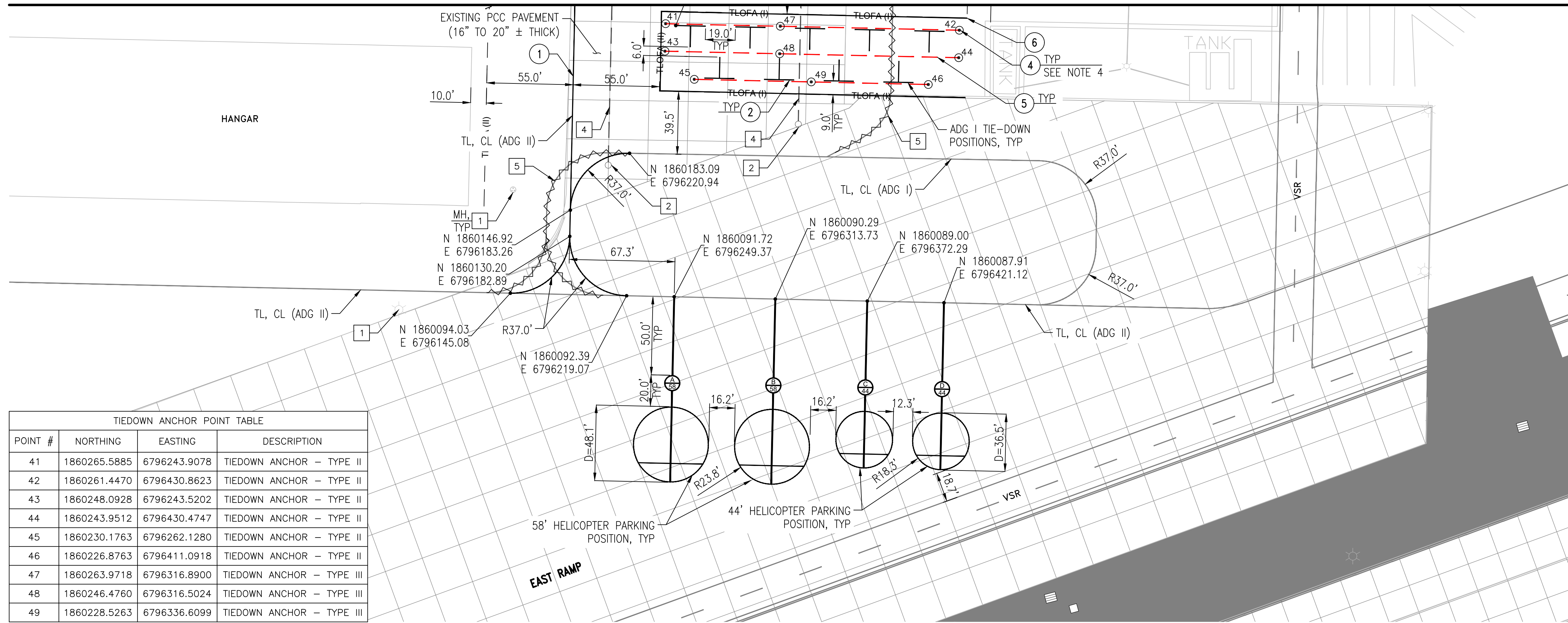

POINT #	NORTHING	EASTING	DESCRIPTION
41	1860265.5885	6796243.9078	TIEDOWN ANCHOR - TYPE II
42	1860261.4470	6796430.8623	TIEDOWN ANCHOR - TYPE II
43	1860248.0928	6796243.5202	TIEDOWN ANCHOR - TYPE II
44	1860243.9512	6796430.4747	TIEDOWN ANCHOR - TYPE II
45	1860230.1763	6796262.1280	TIEDOWN ANCHOR - TYPE II
46	1860226.8763	6796411.0918	TIEDOWN ANCHOR - TYPE II
47	1860263.9718	6796316.8900	TIEDOWN ANCHOR - TYPE III
48	1860246.4760	6796316.5024	TIEDOWN ANCHOR - TYPE III
49	1860228.5263	6796336.6099	TIEDOWN ANCHOR - TYPE III

**CONSTRUCTION NOTES:**

- 1 PAINT 6" WIDE YELLOW TAXILANE CENTERLINE MARKING, PER DETAIL 1/CD-101.
- 2 PAINT 6" WHITE AIRCRAFT TIE-DOWN POSITION MARKING, PER DETAIL 2/CD-101.
- 3 PAINT YELLOW HELICOPTER PARKING POSITION, PER DETAIL 3/CD-102.
- 4 INSTALL TIE-DOWN ANCHOR (ADG I) PER DETAIL 2/CD-202.
- 5 INSTALL TIE-DOWN ANCHOR CABLE ASSEMBLY PER DETAIL 2/CD-202.
- 6 PAINT 6" WIDE WHITE TLOFA MARKING, PER DETAIL 3/CD-101.

**DEMOLITION/DISPOSITION NOTES:**

- 1 PROTECT IN PLACE (ITEM AS SHOWN).
- 2 REMOVE AIRCRAFT TIE-DOWN WITH CONCRETE CAP AND REPAIR CONCRETE PAVEMENT PER DETAIL 3/CD-202.
- 3 REMOVE AIRCRAFT TIE-DOWN AND REPAIR CONCRETE PAVEMENT PER DETAIL 3/CD-202.
- 4 REMOVE AIRCRAFT TIE-DOWN ANCHOR ASSEMBLY.
- 5 OBLITERATE EXISTING PAVEMENT MARKINGS.

**GENERAL NOTES:**

1. CONTRACTOR SHALL PROTECT IN PLACE ALL EXISTING AIRFIELD LIGHTS, UTILITIES, AND STRUCTURES.
2. UNDERGROUND UTILITIES SHOWN ARE APPROXIMATE AND ARE BASED ON RECORD DRAWINGS. CONTRACTOR SHALL INVESTIGATE AND VERIFY UTILITIES BEFORE PROCEEDING WITH WORK.
3. ALL ITEMS TO REMAIN THAT ARE DAMAGED DURING WORK, SHALL BE REPLACED, REPAIRED OR RESTORED TO ITS ORIGINAL CONDITION AT NO COST TO THE OWNER.
4. TIE-DOWN ANCHORS SHALL MAINTAIN MINIMUM 3' O.C. TO ANY CONCRETE JOINT, TYP.
5. COORDINATES ARE BASED ON THE EXISTING SURVEY POINTS SHOWN ON DWG CD-001. PRIOR TO PAINTING AND INSTALLING THE TIE-DOWN ANCHORS, THE CONTRACTOR SHALL FIELD-VERIFY THE COORDINATES AGAINST THE DIMENSIONS AND REPORT ANY DISCREPANCIES TO THE ENGINEER.
6. THIS DRAWING SHALL BE VIEWED & PRINTED IN COLOR.

**STRIPING GENERAL NOTES:**

1. CONTRACTOR SHALL RESTORE ALL STRIPING OUTSIDE IMPROVEMENT AREAS, DAMAGED BY CONSTRUCTION, TO ORIGINAL CLARITY. THIS MAY REQUIRE RESTRIPING OF THE MARKING TO THE NEXT ANGLE POINT OR AS DIRECTED BY THE RESIDENT ENGINEER.
2. ALL NEW PAVEMENT MARKINGS SHALL BE PAINTED WITH 6" WIDE BLACK BORDERS, UNLESS NOTED OTHERWISE OR DIRECTED BY THE RESIDENT ENGINEER. DIMENSIONS SHOWN EXCLUDE BORDER.
3. UNLESS OTHERWISE NOTED, ALL PERMANENT PAVEMENT MARKINGS SHALL RECEIVE GLASS BEADS. EXCEPT FOR BLACK BORDERS.
4. REFRESH/REPAINT OF EXISTING PAVEMENT MARKINGS SHALL BE FOR THE ENTIRETY OF THE MARKING. PARTIAL REFRESH/REPAINT OF EXISTING MARKINGS IS NOT ACCEPTABLE.

**LEGEND:**

- EXISTING CONCRETE PAVEMENT JOINTS
- OBLITERATE EXISTING MARKINGS
- REMOVE EXISTING FENCE
- NEW TIE-DOWN CABLE ASSEMBLY
- EXISTING TIE-DOWN CABLE ASSEMBLY
- NEW TIE-DOWN ANCHOR

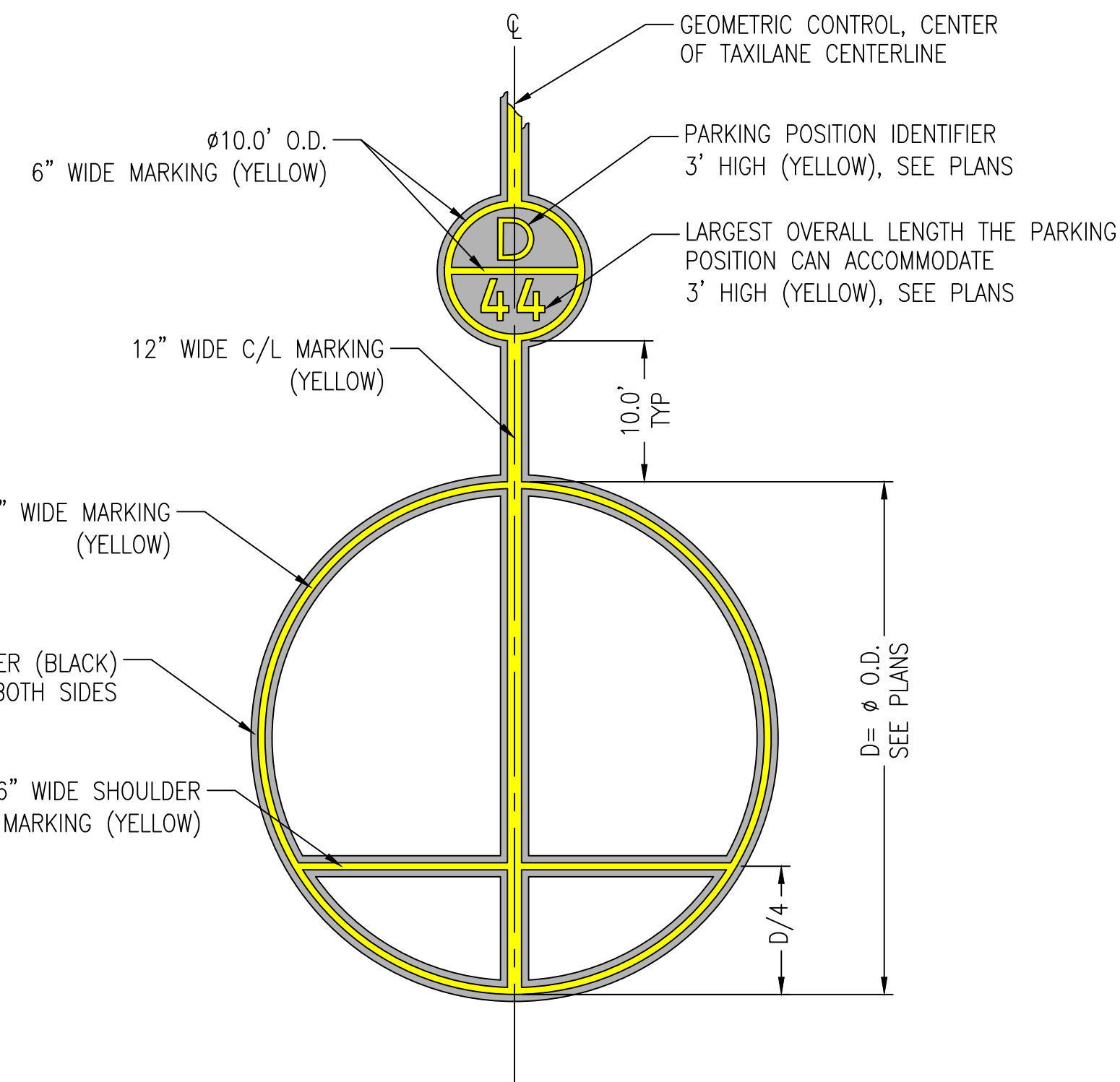
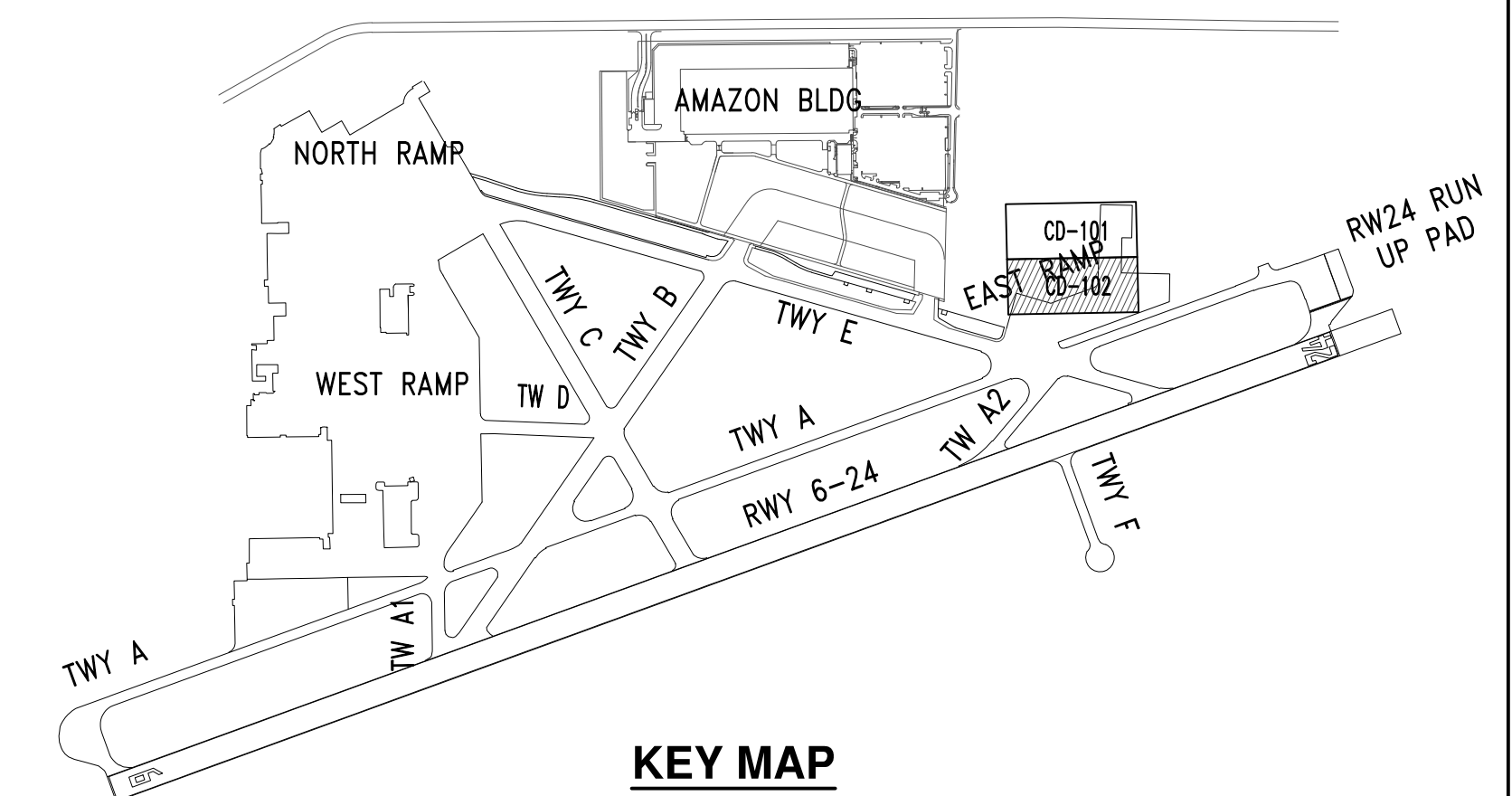

1 HELICOPTER PARKING POSITION MARKING  
NOT TO SCALE

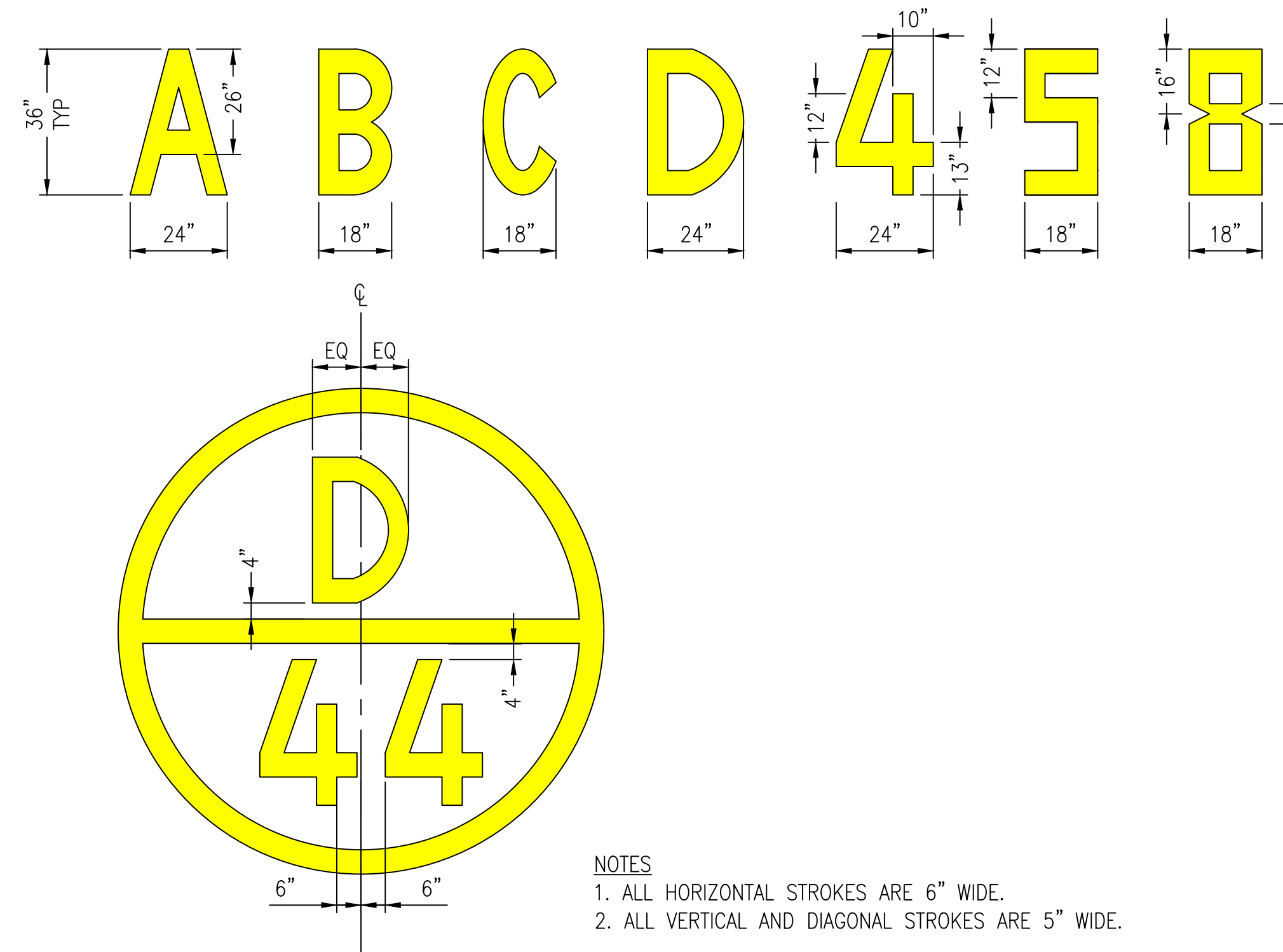

2 HELICOPTER PARKING POSITION IDENTIFIER AND SIZE MARKING  
NOT TO SCALE

- NOTES
1. ALL HORIZONTAL STROKES ARE 6" WIDE.
  2. ALL VERTICAL AND DIAGONAL STROKES ARE 5" WIDE.

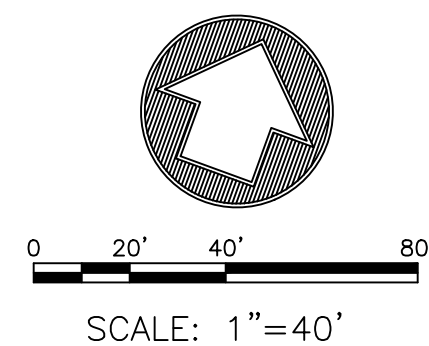

MARK	REVISIONS	BY	APPR.	DATE
	FOR CONSTRUCTION	RL	JB	03-24-26

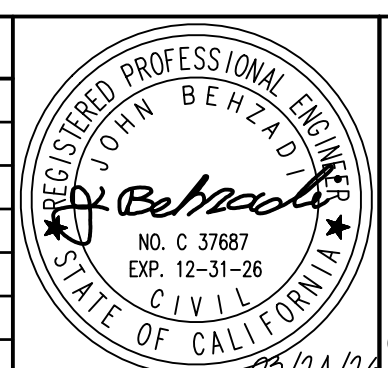

PREPARED BY  
**AECOM**  
AECOM  
999 TOWN & COUNTRY ROAD  
ORANGE, CALIFORNIA 92668  
T: 714.567.2400  
F: 714.567.2729  
www.aecom.com



SAN BERNARDINO INTERNATIONAL AIRPORT AUTHORITY  
APPROVED BY: *[Signature]* 03/24/26  
DATE  
APPROVED BY: \_\_\_\_\_ DATE

SAN BERNARDINO INTERNATIONAL AIRPORT  
GA RAMP  
PARKING RE-DESIGN  
GA MARKINGS REDESIGN,  
SHEET 2 OF 2  
DATE: 03/24/26  
DRAWING NUMBER: CD-102  
SHEET NUMBER: 3 OF 5

D:\Users\gallardo\Box\60738461\_SBD\_Slurry and Paint\900\_CAD\_GIS\910\_CAD\_Working\AG\_CD-101-TO-CD-103\_GA\_Ramp\_RL.dwg  
User: gallardo  
Mar 24, 2026 - 10:27am

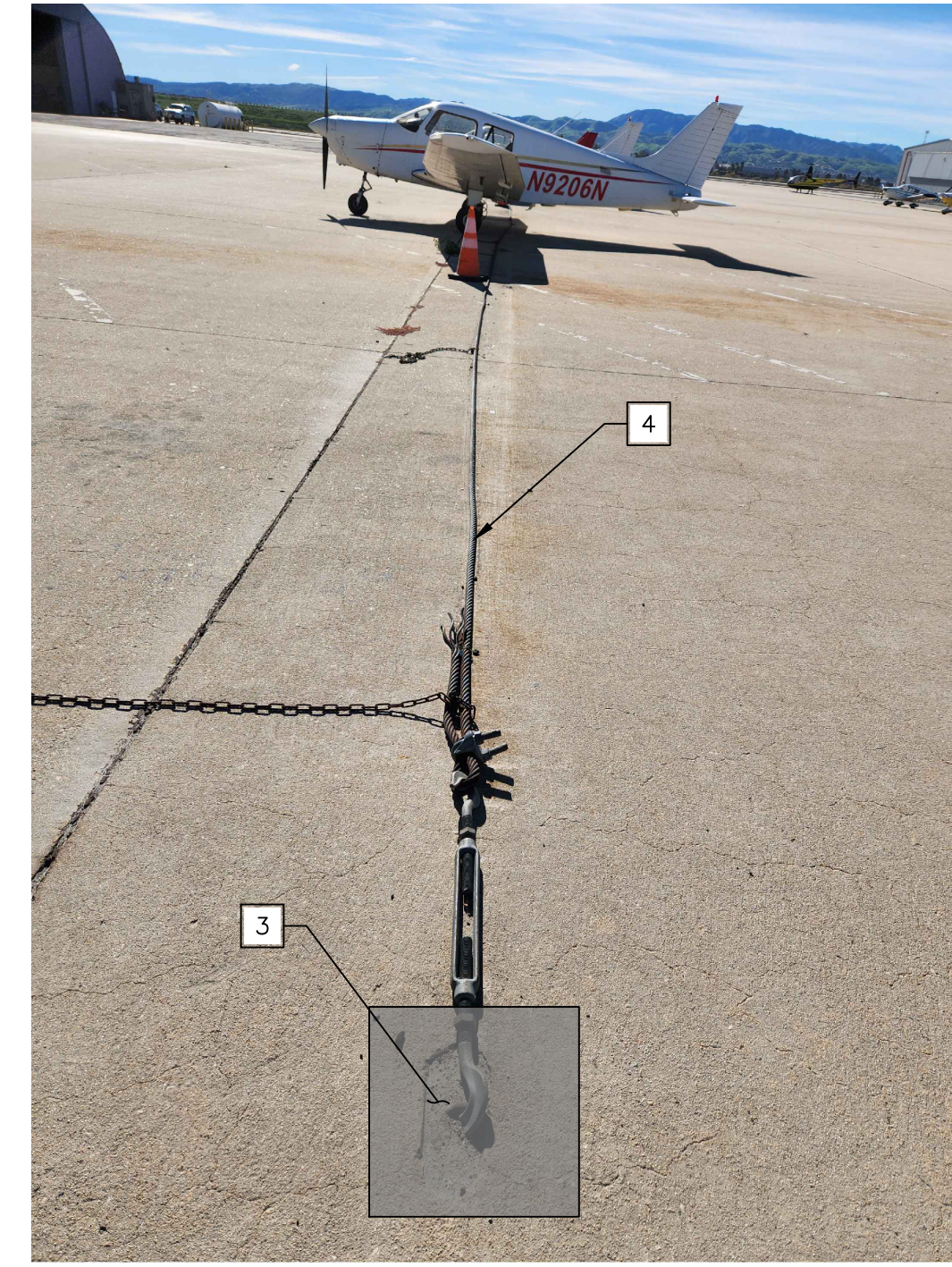
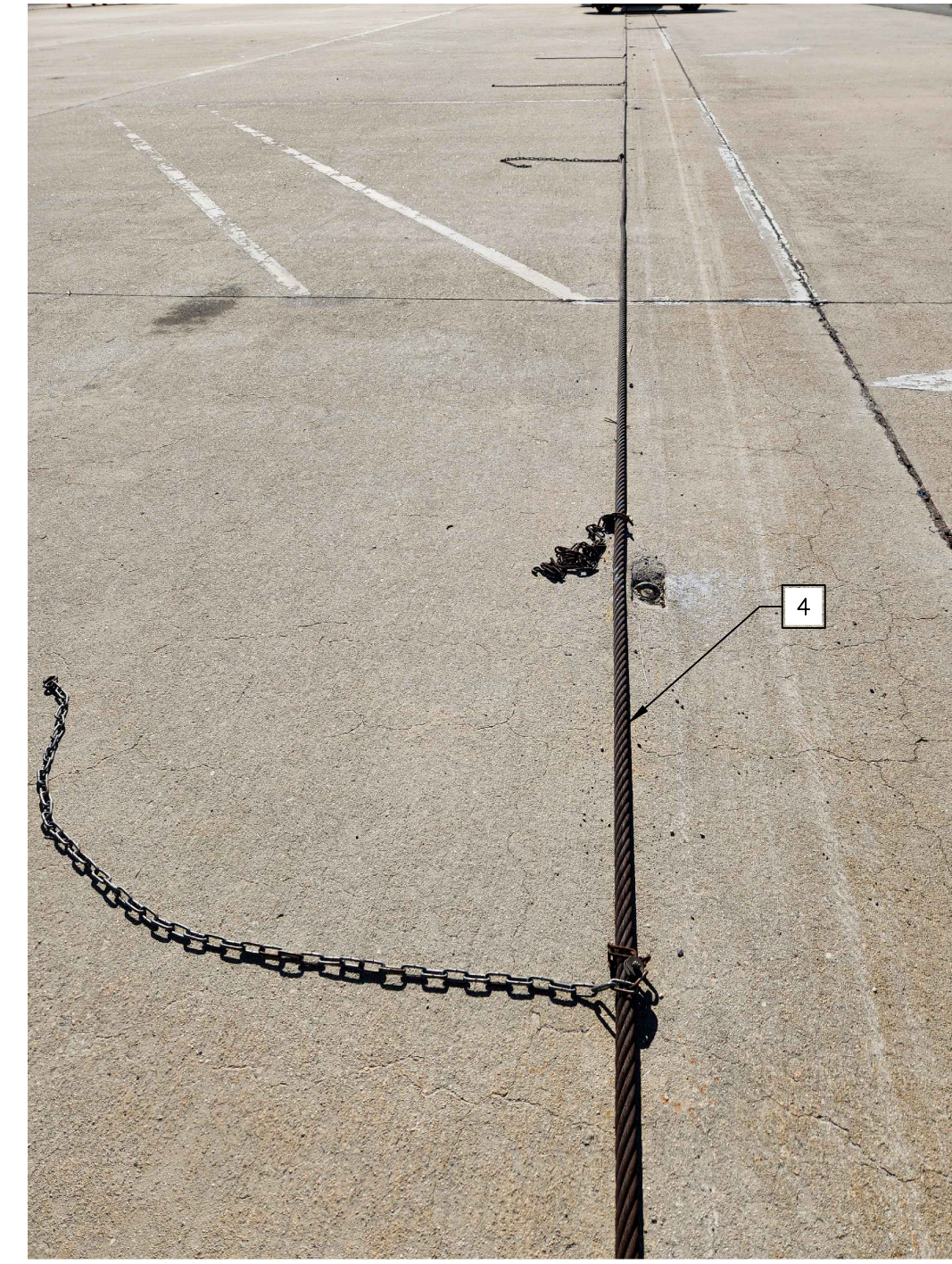
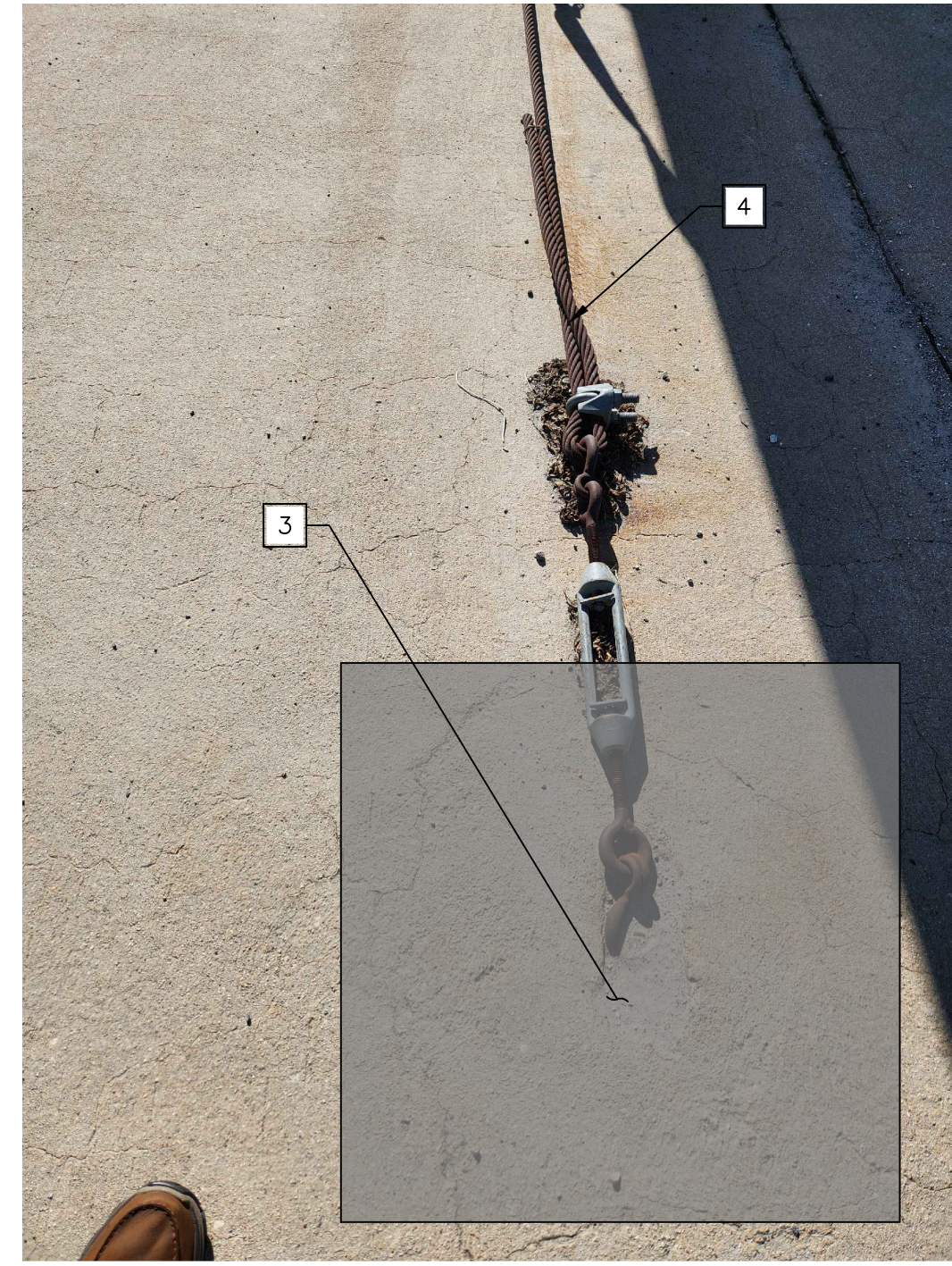

**DEMOLITION/DISPOSITION NOTES:**

- 1 PROTECT IN PLACE (ITEM AS SHOWN).
- 2 REMOVE AIRCRAFT TIE-DOWN WITH CONCRETE CAP AND REPAIR CONCRETE PAVEMENT PER DETAIL 3/CD-202.
- 3 REMOVE AIRCRAFT TIE-DOWN AND REPAIR CONCRETE PAVEMENT PER DETAIL 3/CD-202.
- 4 REMOVE AIRCRAFT TIE-DOWN CABLE ASSEMBLY.

**GENERAL NOTES:**

- 1. CONTRACTOR SHALL PROTECT IN PLACE ALL EXISTING AIRFIELD LIGHTS, UTILITIES, AND STRUCTURES.
- 2. UNDERGROUND UTILITIES SHOWN ARE APPROXIMATE AND ARE BASED ON RECORD DRAWINGS. CONTRACTOR SHALL INVESTIGATE AND VERIFY UTILITIES BEFORE PROCEEDING WITH WORK.
- 3. ALL ITEMS TO REMAIN THAT ARE DAMAGED DURING WORK, SHALL BE REPLACED, REPAIRED OR RESTORED TO ITS ORIGINAL CONDITION AT NO COST TO THE OWNER.

**STRIPING GENERAL NOTES:**

- 1. CONTRACTOR SHALL RESTORE ALL STRIPING OUTSIDE IMPROVEMENT AREAS, DAMAGED BY CONSTRUCTION, TO ORIGINAL CLARITY. THIS MAY REQUIRE RESTRIPING OF THE MARKING TO THE NEXT ANGLE POINT OR AS DIRECTED BY THE RESIDENT ENGINEER.
- 2. ALL NEW PAVEMENT MARKINGS SHALL BE PAINTED WITH 6" WIDE BLACK BORDERS, UNLESS NOTED OTHERWISE OR DIRECTED BY THE RESIDENT ENGINEER. DIMENSIONS SHOWN EXCLUDE BORDER.
- 3. UNLESS OTHERWISE NOTED, ALL PERMANENT PAVEMENT MARKINGS SHALL RECEIVE GLASS BEADS. EXCEPT FOR BLACK BORDERS.
- 4. REFRESH/REPAINT OF EXISTING PAVEMENT MARKINGS SHALL BE FOR THE ENTIRETY OF THE MARKING. PARTIAL REFRESH/REPAINT OF EXISTING MARKINGS IS NOT ACCEPTABLE.

**LEGEND:**



1 AIRCRAFT TIE-DOWN ANCHOR, PHOTOS  
SCALE: NTS

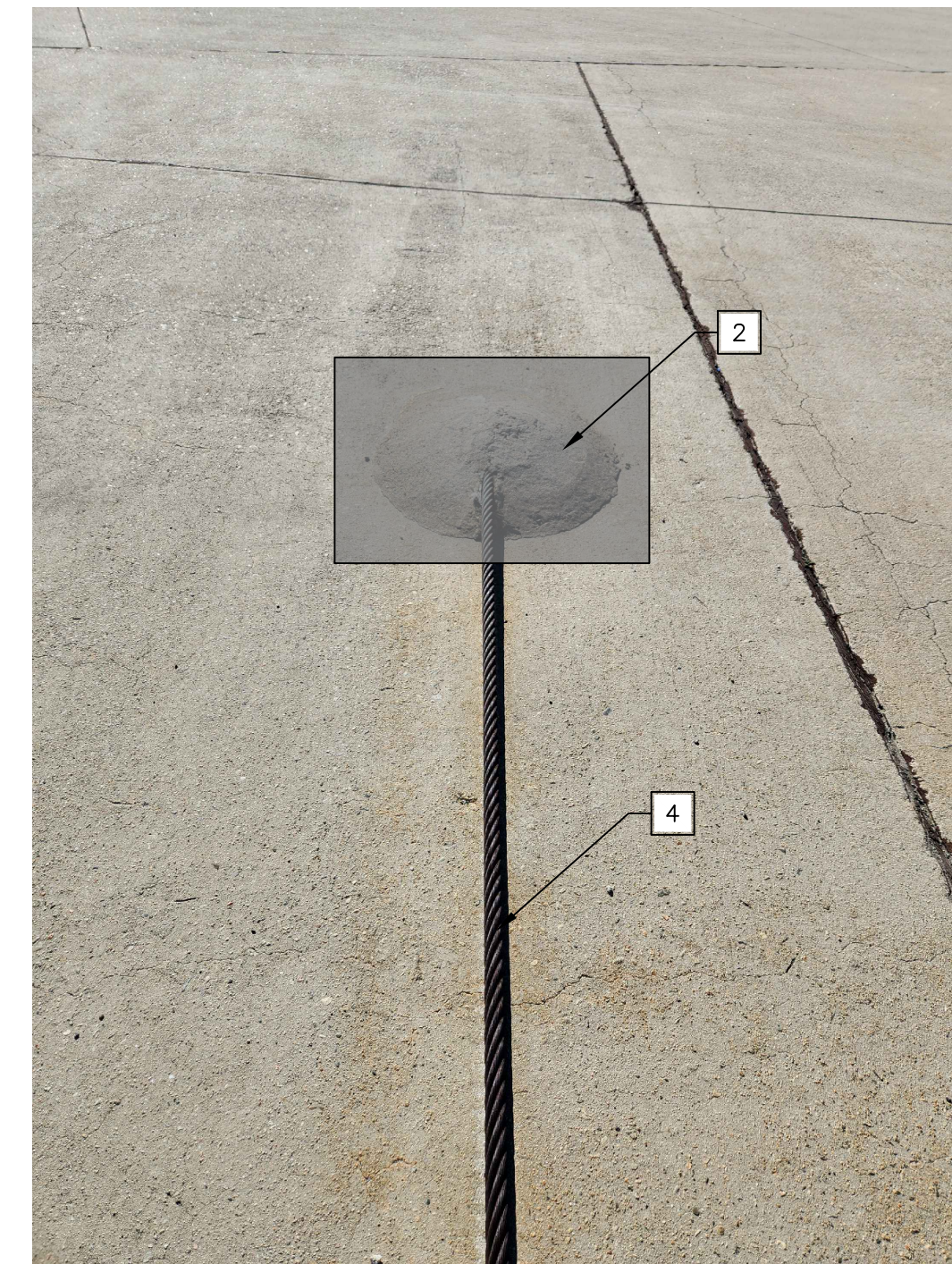

2 AIRCRAFT TIE-DOWN ANCHOR WITH CONCRETE CAP - PHOTO  
SCALE: NTS

MARK	REVISIONS	BY	APPR.	DATE	SAN BERNARDINO INTERNATIONAL AIRPORT		DATE
	FOR CONSTRUCTION	AG	JB	03-24-26	GA RAMP PARKING RE-DESIGN PAVEMENT REPAIR DETAILS		03/24/26
					SHEET NUMBER		CD-201
					SHEET NUMBER		4 OF 5

03/24/26

PREPARED BY

**AECOM**

AECOM  
999 TOWN & COUNTRY ROAD  
ORANGE, CALIFORNIA 92668

T: 714.567.2400  
F: 714.567.2729  
www.aecom.com

SAN BERNARDINO  
INTERNATIONAL AIRPORT AUTHORITY

APPROVED BY: *[Signature]* 03/24/26  
DATE

APPROVED BY: \_\_\_\_\_ DATE

**CONCRETE SPALL REPAIR PROCEDURE (SAW & PATCH)**

1. SAWCUT A BOUNDARY (RECTANGULAR) AROUND THE SPALLED AREA OR NEAREST CONCRETE CRACK TO A MINIMUM DEPTH OF 2". CORE DRILL AT CORNERS OR CHIP-OUT TO ELIMINATE OVER-SAWING. BREAKOUT AND REMOVE UNSOUND CONCRETE WITHIN SAWCUTS TO A MINIMUM DEPTH OF 2". CLEAN EXPOSED CAVITY SURFACES.
2. CLEAN THE AREA TO PREVENT DEBRIS FROM REENTERING THE SPALL REPAIR AREA.
3. AFTER REPAIR OPERATION IS COMPLETE, CLEAN THE SURROUNDING PAVEMENT OF ALL POTENTIAL MATERIALS THAT MAY CAUSE FOD.
4. A 2" SAWCUT DEPTH IS USED TO BEGIN THE CHIPPING AND REMOVAL PROCESS, TO REMOVE ALL UNSOUND CONCRETE FOR PARTIAL DEPTH REPAIR. IF UNSOUND CONCRETE CONTINUES TO BELOW 1/3 PANEL THICKNESS OR MORE THAN 6" WIDE SPALL REPAIR, NOTIFY THE ENGINEER.
5. CONCRETE FOR SPALL REPAIR SHALL BE RAPID SETTING POLYMER CONCRETE, PPC 1121 POLYESTER POLYMER CONCRETE AS MANUFACTURED BY Kwikbond OR DELPATCH ELASTOMERIC CONCRETE AS MANUFACTURED BY D.S. BROWN OR APPROVED EQUAL WITH 6,000 PSI COMPRESSIVE STRENGTH. THE CONTRACTOR SHALL APPLY THE PRIMER TO THE REPAIR CAVITY AND ALLOW FOR CURING AND PLACE THE PATCH MATERIAL PER MANUFACTURER'S RECOMMENDATION.

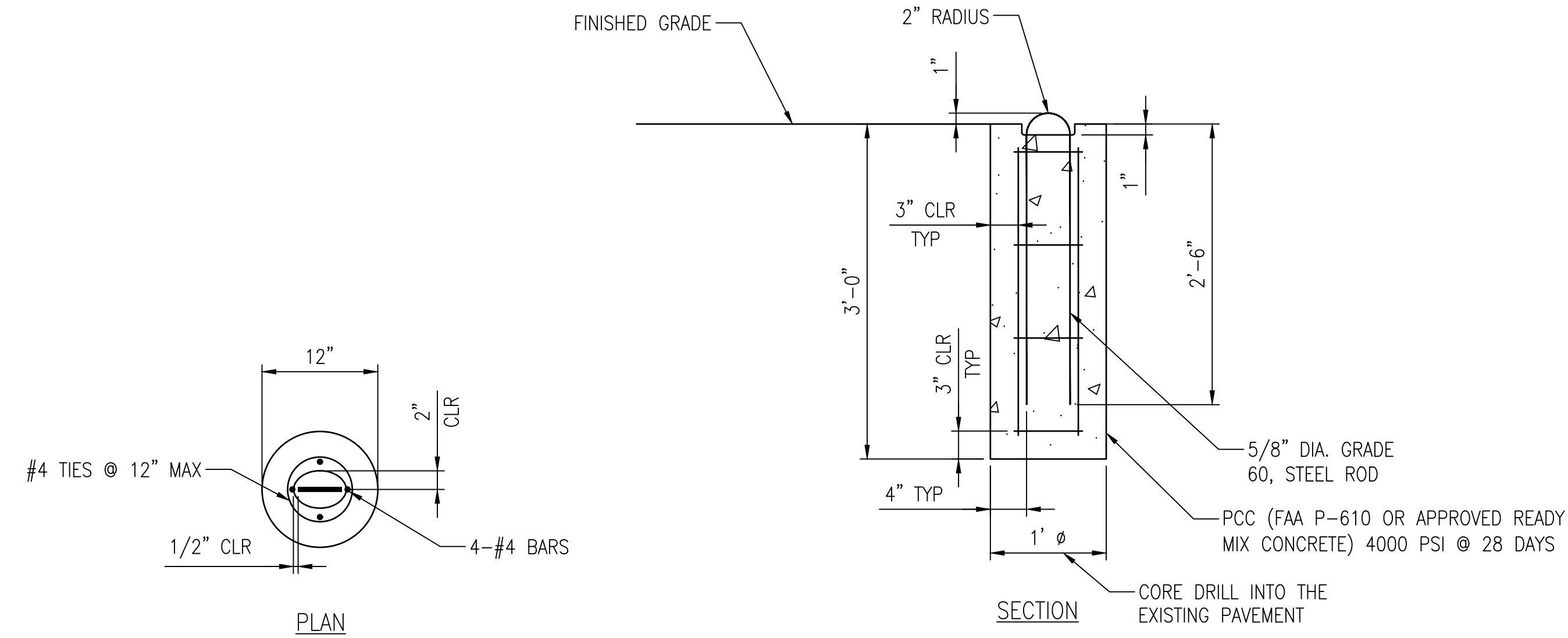
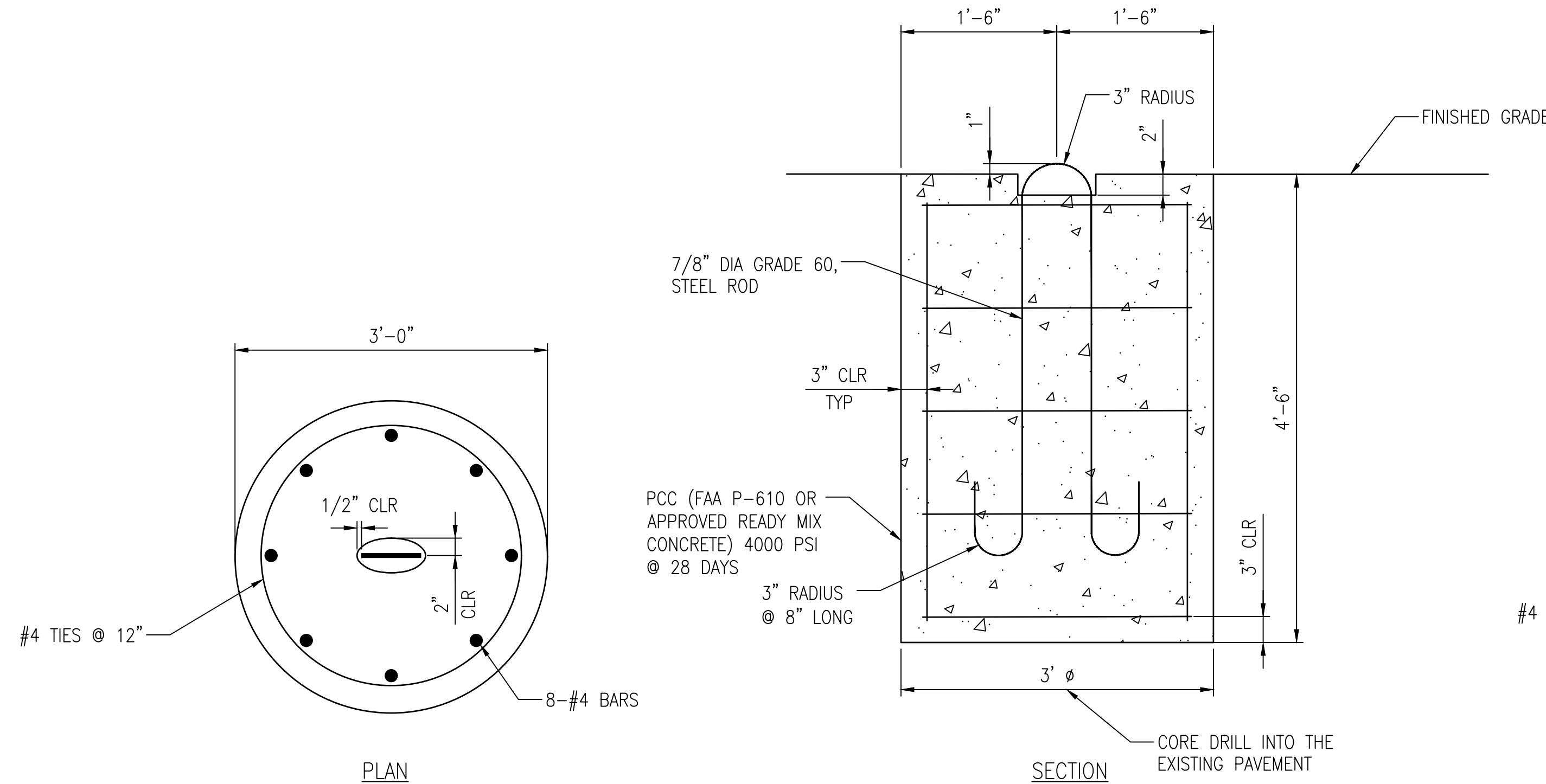

**1 AIRCRAFT TIE-DOWN ANCHOR, (END) TYPE II**  
SCALE: NTS

**(INTERMEDIATE) TYPE III**

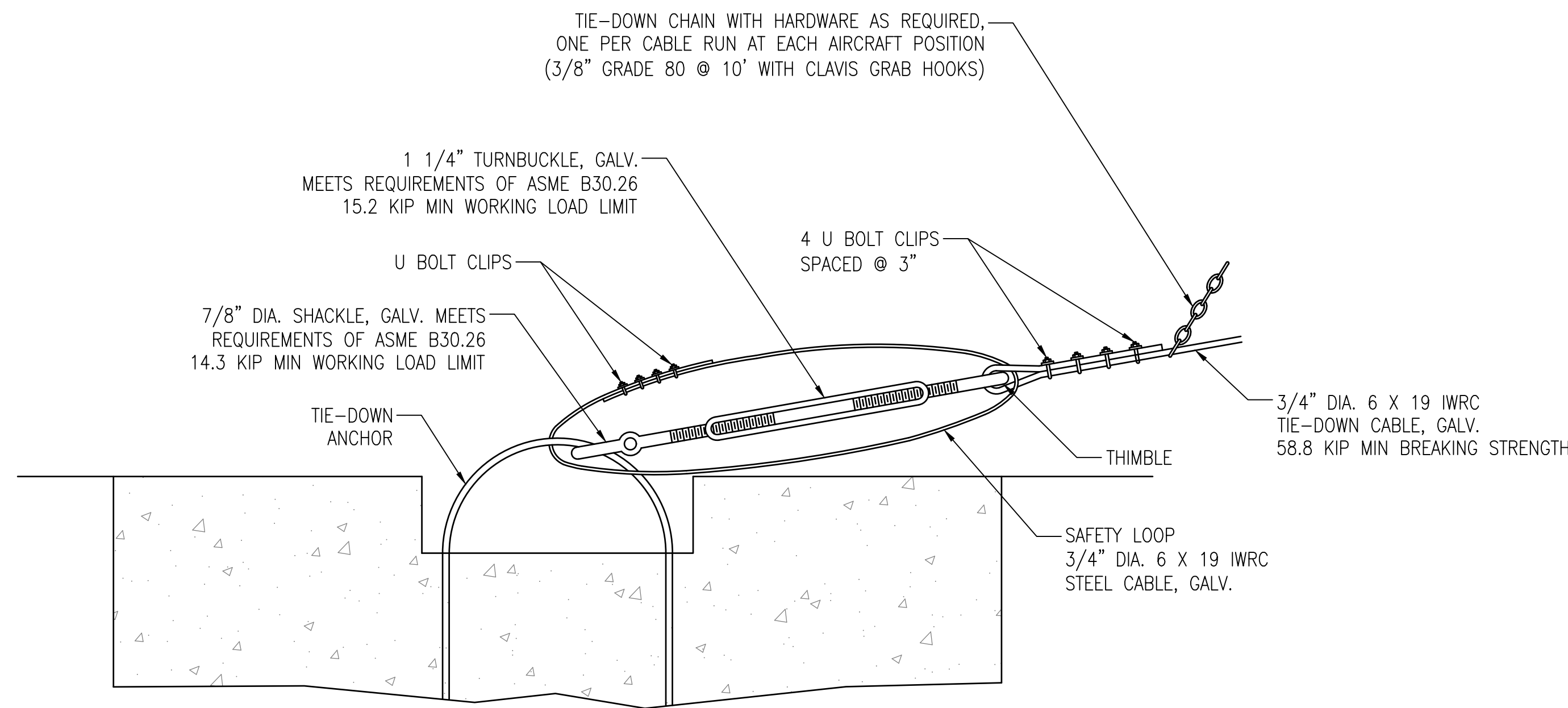

**2 CABLE TIE-DOWN ASSEMBLY-SECTION**  
SCALE: NTS

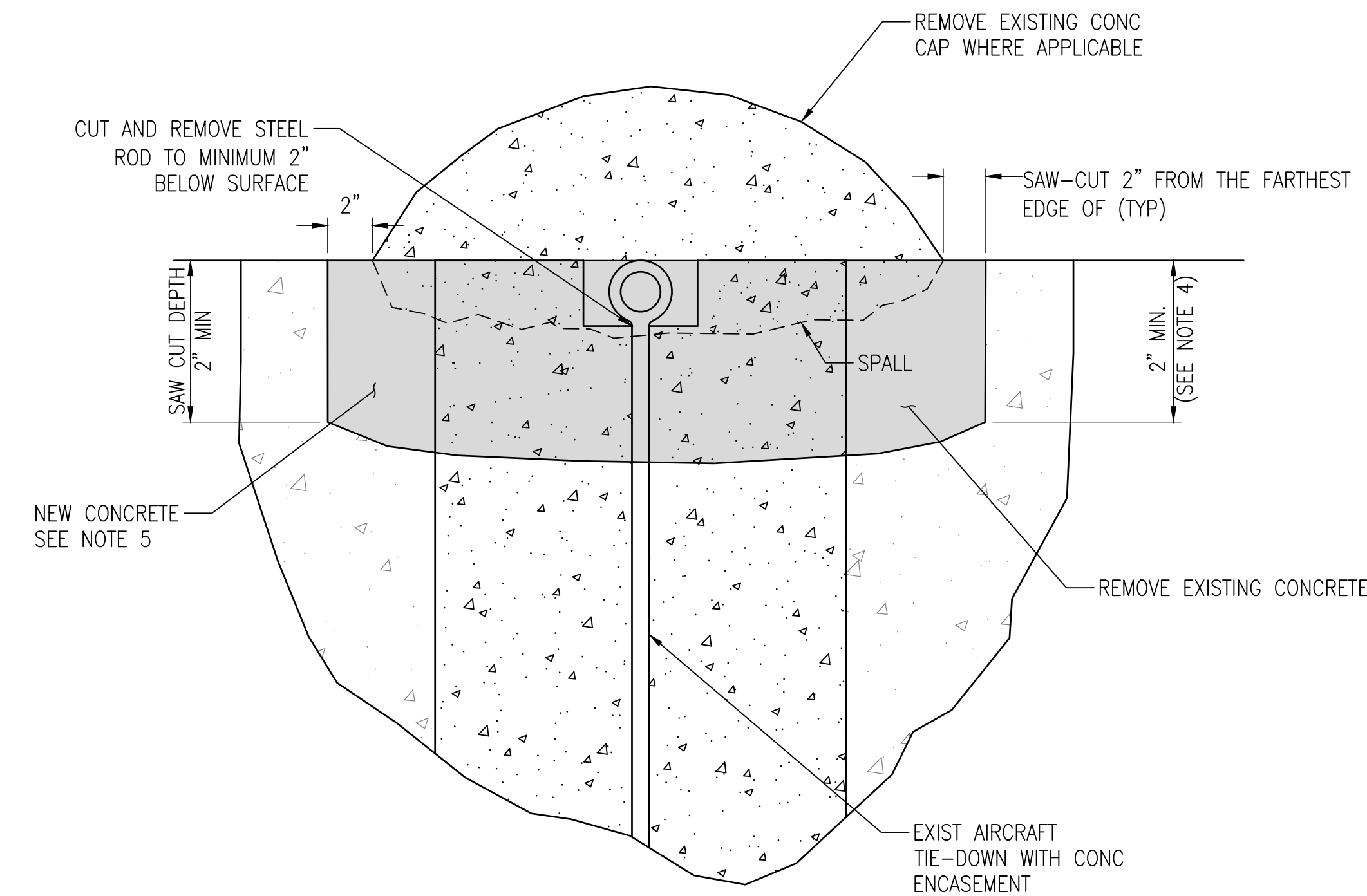

**3 SPALL REPAIR AT CONCRETE AIRCRAFT TIE-DOWN ANCHOR**  
SCALE: NTS

MARK	REVISIONS	BY	APPR.	DATE
	FOR CONSTRUCTION	AG	JB	03-24-26

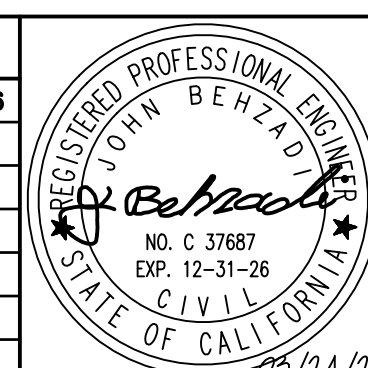

PREPARED BY  
**AECOM**  
AECOM  
999 TOWN & COUNTRY ROAD  
ORANGE, CALIFORNIA 92668  
T: 714.567.2400  
F: 714.567.2729  
www.aecom.com

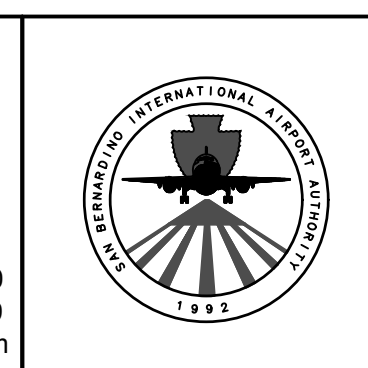

SAN BERNARDINO INTERNATIONAL AIRPORT AUTHORITY  
APPROVED BY: *[Signature]* 03/24/26  
DATE  
APPROVED BY: \_\_\_\_\_ DATE

SAN BERNARDINO INTERNATIONAL AIRPORT  
GA RAMP  
PARKING RE-DESIGN  
PAVEMENT REPAIR DETAILS  
SHEET 2 OF 2  
DATE: 03/24/26  
DRAWING NUMBER: CD-202  
SHEET NUMBER: 5 OF 5

	<p><b>TO: San Bernardino International Airport Authority Commission</b></p> <p><b>DATE: April 22, 2026</b></p> <p><b>ITEM NO: 6</b></p> <p><b>PRESENTER: Jillian Ubaldo, Assistant Secretary of the Commission</b></p>
---	--

**SUBJECT: APPROVE MEETING MINUTES: MARCH 25, 2026**

**SUMMARY**

Submitted for consideration and approval by the San Bernardino International Airport Authority (SBIAA) Commission: Meeting minutes of the regular meeting held Wednesday, March 25, 2026.

**RECOMMENDED ACTION(S)**

Approve meeting minutes of the regular meeting held March 25, 2026.

**FISCAL IMPACT**

None.

PREPARED BY:	Yajaira Maldonado
CERTIFIED AS TO AVAILABILITY OF FUNDS:	N/A
APPROVED AS TO FORM AND LEGAL CONTENT:	Scott Huber
FINAL APPROVAL:	Michael Burrows

**BACKGROUND INFORMATION**

None.

**Attachments:**

1. March 25, 2026 regular meeting minutes

# SAN BERNARDINO INTERNATIONAL AIRPORT AUTHORITY

## REGULAR MEETING COMMISSION ACTIONS

WEDNESDAY, MARCH 25, 2026

5:00 P.M.

MAIN AUDITORIUM – Norton Regional Event Center 1601 East Third Street, San Bernardino, CA



A regional joint powers authority dedicated to the reuse of Norton Air Force Base  
for the economic benefit of the East Valley

### Commission Members

#### City of Colton

Mayor Frank J. Navarro	Present
Councilmember John Echevarria (alt)	Present (In Audience)

#### City of Loma Linda

Councilmember Rhodes Rigsby	Present
Mayor Phillip Dupper (alt)	Absent

#### County of San Bernardino

Supervisor Joe Baca, Jr., Vice President	Present
Supervisor Dawn Rowe (alt)	Absent

#### City of San Bernardino

Councilmember Kim Knaus	Present
Councilmember Theodore Sanchez, Secretary	Present
Councilmember Fred Shorett (alt)	Absent

#### City of Highland

Mayor Penny Lilburn, President	Present
Mayor Pro Tem Jimmy Saldana (alt)	Present (In Audience)

#### Staff Members and Others Present

Michael Burrows, Chief Executive Officer	Jillian Ubaldo, Assistant Secretary of the Commission
Mark Gibbs, Director of Aviation	Jonathan Galvan, Airport Manager
Jeff Barrow, Director of Development	Amber Casarez, Marketing Manager
Mark Cousineau, Director of Finance	Scott Huber, Legal Counsel, Cole Huber LLP

**March 25, 2026**

The Regular Meeting of the San Bernardino International Airport Authority was called to order by President Penny Lilburn at approximately 5:09 p.m. on Wednesday, March 25, 2026.

**A. CALL TO ORDER / ROLL CALL**

Roll call was duly noted and recorded by voice.

Members of the Commission and staff joined Councilmember Rhodes Rigsby in the Pledge of Allegiance.

**B. CLOSED SESSION PUBLIC COMMENT**

There were no closed session public comment.

**C. CLOSED SESSION**

President Penny Lilburn recessed to closed session at 5:10 p.m. Mr. Scott Huber, Legal Counsel, Cole Huber, LLP, read the closed session items as posted on the Agenda.

- a. Conference with Real Property Negotiator Pursuant to Government Code Section 54956.8  
Property: 105 North Leland Norton Way, San Bernardino CA 92408  
Negotiating Parties: Michael Burrows, SBIAA Chief Executive Officer and Betty Lui, Transportation Security Administration (TSA)
- b. Conference with Real Property Negotiator Pursuant to Government Code Section 54956.8 Property: 2235 East Perimeter Road, San Bernardino CA 92408  
Negotiating Parties: Michael Burrows, SBIAA Chief Executive Officer and Kevin Horan, SBRETC
- c. Conference with Real Property Negotiator Pursuant to Government Code Section 54956.8  
Property: 275 N. Leland Norton Way, San Bernardino CA 92408  
Negotiating Parties: Michael Burrows, SBIAA Chief Executive Officer and Mike Allen, Executive Vice President, Bulk Fuel Sales, Titan Aviation Fuels
- d. Conference with Real Property Negotiator Pursuant to Government Code Section 54956.8  
Property: Approximately 4 acres of vacant land at the San Bernadino International Airport, San Bernardino CA 92408  
Negotiating Parties: Michael Burrows, SBIAA Chief Executive Officer and Michael Allawos, Technical Advisor
- e. Conference with Legal Counsel pursuant to Gov. Code 54956.9(d) – significant exposure to litigation: one case

**D. REPORT ON CLOSED SESSION**

President Penny Lilburn reconvened the meeting at 6:26 p.m. President Penny Lilburn asked Mr. Scott Huber, legal Counsel, Cole Huber, LLP, if there were any reportable items Mr. Huber reported that there were none.

E. **ITEMS TO BE ADDED OR DELETED**

There were no items to be added or deleted.

F. **CONFLICT OF INTEREST DISCLOSURE**

1. President Penny Lilburn stated Commission members should note the item(s) listed which might require member abstentions.

There were no conflicts noted.

G. **INFORMATIONAL ITEMS**

Mr. Michael Burrows, Chief Executive Officer, presented the following informational items:

2. Informational Items
  - a. Chief Executive Officer's Report
  - b. Legislative Update
  - c. Report on FAA Grants
  - d. Green Energy Element Update
- 2b. Mr. Michael Burrows, Chief Executive Officer, reported that he and Director of Administration Catherine Pritchett traveled to Washington, D.C. with Inland Action to discuss the surface transportation bill, which is currently under a continuing resolution. He noted that continuing resolutions present challenges for advancing multi-year, multi-million-dollar transportation projects; however, feedback was received from legislators. Mr. Burrows reported that meetings were held with U.S. Customs and Border Protection (CBP) regarding the need for additional officers to support increased activity. He stated that the meeting was productive. He also reported that the U.S. Department of Transportation expressed support and offered to coordinate with CBP on behalf of the airport. Mr. Burrows further reported that the process to appoint a new Secretary of Homeland Security is underway. He noted that new leadership may assist in facilitating additional business activity.

President Penny Lilburn stated that Commission members are available to assist with advocacy efforts with U.S. Customs and Border Protection (CBP) on behalf of the airport.

- 2c. Mr. Mark Gibbs, Director of Aviation, reported that San Bernardino International Airport has been designated as a primary airport by the Federal Aviation Administration (FAA) due to increased passenger activity. He noted that this designation qualifies the airport for additional federal grant funding to support major infrastructure improvements. Mr. Gibbs reported that the airport currently has three major federally funded projects underway. He emphasized that these projects are funded through FAA grants, which are supported by a user fee system, and do not utilize local or state funds.

March 25, 2026

- 2d. Ms. Amber Casarez, Marketing Manager, provided a brief report on the new Green Energy landing page on FlySBD.com, developed in preparation for Earth Day, and opened the item for feedback from Commission members.

H. **COMMISSION CONSENT ITEMS**

Let the record reflect that all votes were done by roll call with each Commissioners’ name and vote stated by voice.

- 3. Register of Demands for February 2026
- 4. Receive and file Treasurer's Report for January 31, 2026, for the San Bernardino International Airport Authority (SBIAA)
- 5. Approve a 48-month Lease Agreement for a 2026 Lincoln Corsair with South Bay Ford, Inc. in an amount not to exceed \$41,114
- 6. Authorize staff to advertise a request for qualifications for Design-Build Services for the SBD Above and Beyond Project
- 7. Approve Meeting Minutes: February 25, 2026

**ACTION:** Approve Agenda Item Nos. 3–7

RESULT: **ADOPTED [UNANIMOUSLY]**  
 MOTION/SECOND: Baca / Navarro  
 AYES: Lilburn, Baca, Sanchez, Navarro, Rigsby, and Knaus  
 NAYS: None  
 ABSTENTIONS: None  
 ABSENT: None

I. **COMMISSION ACTION ITEMS**

Let the record reflect that all votes were done by roll call with each Commissioners’ name and vote stated by voice.

- 8. Receive and file the Annual Independent Financial Audit Report of the San Bernardino International Airport Authority (SBIAA) for the Fiscal Year ending June 30, 2025

Mr. Mark Cousineau, Director of Finance, introduced David Showalter of Eide Bailly, who provided a brief report on Agenda Item No. 8.

President Penny Lilburn expressed appreciation to staff for their efforts on the audit process.

This item was for discussion purposes only; no formal action was taken.

- 9. Approve an agreement with Fuse Connect, LLC to provide In-Terminal Advertising Services at the San Bernardino International Airport

Mr. Mark Gibbs, Director of Aviation, shared a brief report on Agenda Item No. 9.

**ACTION:** Approve the form of agreement with Fuse Connect, LLC for In-Terminal Advertising Concession services for a three (3)-year term with two (2)-additional, one (1)-year extension options; and authorize the Chief Executive Officer to execute all related documents.

March 25, 2026

RESULT: **ADOPTED [UNANIMOUSLY]**  
MOTION/SECOND: Baca / Sanchez  
AYES: Lilburn, Baca, Sanchez, Navarro, Rigsby, and Knaus  
NAYS: None  
ABSTENTIONS: None  
ABSENT: None

- 10. Approve Amendment No. 5 with C & A Janitorial, LLC in an additional contract authority amount not to exceed \$363,100 for the second one-year extension option term for janitorial services at San Bernardino International Airport Authority facilities

Mr. Jonathan Galvan, Airport Manager presented a brief report on Agenda Item No. 10.

**ACTION:** Approve Amendment No. 5 to the Services Agreement with C & A Janitorial, LLC in an additional contract authority amount not to exceed \$363,100 for a total revised five (5)-year contract amount that will not exceed \$1,826,310 for routine janitorial services and supplies at certain SBIAA buildings; and authorize the Chief Executive Officer to execute all related documents.

RESULT: **ADOPTED [UNANIMOUSLY]**  
MOTION/SECOND: Baca / Knaus  
AYES: Lilburn, Baca, Sanchez, Navarro, Rigsby, and Knaus  
NAYS: None  
ABSTENTIONS: None  
ABSENT: None

- 11. Discussion and direction regarding the potential establishment of the Executive Committee as a Standing Committee and Adoption of a Regular Meeting Schedule

Mr. Scott Huber, Legal Counsel, presented a brief report on Agenda Item No. 11.

Councilmember Rhodes Rigsby inquired about the advantages of formalizing the committee.

President Penny Lilburn noted that the Commission currently has standing committees that are not in violation of the Brown Act. She stated that formalizing the Executive Committee as a standing committee would allow for a structured agenda and more formal review of priority items and activities prior to regular Commission meetings, in order to maintain transparency.

Mr. Huber noted that, although additional administrative work would be required to prepare an agenda, the purpose would be to agendize items to facilitate feedback from the Executive Committee.

Mr. Michael Burrows, Chief Executive Officer, stated that staff is able to accommodate the preparation of a new agenda and drafting of a resolution, should it be the will of the Commission.

Secretary Theodore Sanchez stated that he has served since 2018 and that airport activity has increased substantially during that time. He noted that the Board is tasked with oversight, governance, and policy enactment, and that expanding the Board’s oversight is important given the increased activity.

Mr. Huber noted that this item is a recommendation only, to be brought back at a future meeting for formal consideration of establishing the committee by resolution.

Councilmember Rhodes Rigsby expressed concern that the explanations provided would add rigidity to the committee structure and that notice requirements could impede the efficient transmission of information.

March 25, 2026

He also expressed concern that an Executive Committee could approve items reserved for the Commission. He further stated that an ad hoc committee may provide greater flexibility, particularly with respect to last-minute items for discussion.

President Penny Lilburn clarified that the Executive Committee would not be responsible for approving items prior to Board meetings, but rather for providing additional information to the Board to enhance transparency.

Mr. Burrows noted that sensitive information would be addressed in closed session.

Secretary Theodore Sanchez stated that many cities utilize legislative review committees to evaluate what is working and what is not, and to bring recommendations back to the full Board. He clarified that such a committee is not intended to curtail the authority of the Board or preclude staff proposals from reaching the Board. Rather, its purpose is to obtain feedback and improve efficiency.

Councilmember Kim Knaus noted that the recommendation would support transparency in the committee process.

**ACTION:** Staff recommends that the Commission discuss the proposed formalization of the Executive Committee as a Standing Committee and provide specific direction regarding its desired scope and meeting frequency. Upon receiving this direction, staff will return at a subsequent meeting with the necessary procedural amendments and resolution to reflect the Commission’s consensus.

RESULT:	<b>ADOPTED [UNANIMOUSLY]</b>
MOTION/SECOND:	Sanchez / Knaus
AYES:	Lilburn, Baca, Sanchez, and Knaus
NAYS:	None
ABSTENTIONS:	Navarro and Rigsby
ABSENT:	None

12. Conduct Business Plan Update Workshop

Mr. Michael Burrows, Chief Executive Officer, referenced a PowerPoint presentation entitled “San Bernardino International Airport Authority (SBIAA) Business Plan Update Vol. 5”. Mr. Burrows provided Commission members with a hard copy of the working draft and opened the item for feedback.

This item was for discussion purposes only; no formal action was taken.

13. Review Status of the Action Plan for the San Bernardino International Airport Authority (SBIAA) through June 30, 2026

Mr. Michael Burrows, Chief Executive Officer, referenced a PowerPoint presentation entitled “June 30, 2026 – Airport Focal Areas” (as contained on pages 217-219 in the agenda packet). Mr. Burrows thanked staff for their work in keeping the agency on track in accordance with the action plan. He noted that the Federal Aviation Administration (FAA) will be conducting an ADA audit and expressed appreciation to staff for proactively preparing for it.

He reported that the agency is in final review of the DC fast charging (DCFC) grant program with the South Coast Air Quality Management District (AQMD), and noted that the airport may be one of the few, if not the only, airports to apply for the program, crediting President Penny Lilburn for the recommendation.

**March 25, 2026**

Mr. Burrows also reported that Mr. Mark Gibbs received positive feedback from the FAA regarding the planned upgrade of jet bridges to more modern equipment, and he expressed appreciation to the County for the grant support.

He further stated that at a future meeting, staff anticipates presenting the inter-terminal walkway project for award, along with Mr. Allowas, as part of the Green Energy Element initiative.

This item was for discussion purposes only; no formal action was taken.

**J. ADDED AND DEFERRED ITEMS**

There were no items to be added or deferred.

**K. OPEN SESSION PUBLIC COMMENT**

There were no public comments.

**L. COMMISSION MEMBER COMMENT**

President Penny Lilburn thanked staff for the tour and noted that Aloft has made significant progress on its hangar.

Mr. Michael Burrows, Chief Executive Officer, noted that Aloft has made significant progress on its hangar and encouraged members who were unable to attend the tour to contact staff to schedule a visit.

**M. ADJOURNMENT**

There being no further business before the Commission, President Penny Lilburn declared the meeting adjourned at 6:58 p.m.

**Approved at a Regular Meeting of the San Bernardino International Airport Authority on Wednesday, April 22, 2026.**

---

**Jillian Ubaldo**  
**Assistant Secretary of the Commission**

	<p><b>TO: San Bernardino International Airport Authority Commission</b></p> <p><b>DATE: April 22, 2026</b></p> <p><b>ITEM NO: 7</b></p> <p><b>PRESENTER: Mark Cousineau, Director of Finance</b></p>
---	--

**SUBJECT: CONSIDER AND ADOPT PROPOSED BUDGET ADJUSTMENTS FOR FISCAL YEAR 2025-2026**

**SUMMARY**

The proposed adjustments modify the adopted San Bernardino International Airport Authority's (SBIAA) budget to reflect improved estimates and changes in conditions in the accounts reflected in the Proposed Budget Adjustments Table.

**RECOMMENDED ACTION(S)**

Consider and adopt budget adjustments reflected in the Proposed Budget Adjustments Table for Fiscal year 2025-2026.

**FISCAL IMPACT**

The composition for the requested adjustments is detailed in the attached "Proposed Budget Adjustment Table". The combined net effect on the San Bernardino International Airport Authority's Fiscal Year 2025-2026 Budget, if approved, would be a net decrease in budgetary income of \$67,988.

PREPARED BY:	Mark Cousineau
CERTIFIED AS TO AVAILABILITY OF FUNDS:	Mark Cousineau
APPROVED AS TO FORM AND LEGAL CONTENT:	Scott Huber
FINAL APPROVAL:	Michael Burrows

**BACKGROUND INFORMATION**

On June 25, 2025, the San Bernardino International Airport Authority (SBIAA) Commission adopted the SBIAA Budget for Fiscal Year 2025-2026. SBIAA staff determined the following adjustments are necessary based on changes since the budget was approved. Capital Project adjustments require Commission approval.

The net effect of the proposed budget adjustments is a decrease in budgetary net income of \$67,988. A \$2,730,437 increase in estimated revenues is comprised of federal and local grant revenues (\$2,250,000 and \$250,000, respectively); increased lease revenue (\$205,457), and increased Luxivair-SBD ground service equipment fuel sales (\$25,000) due to increased market prices of fuel. The increase in fuel prices is also reflected in offsetting increases in Luxivair-SBD's Jet A inventory purchases and fuel sales for a zero-dollar change.

A \$2,798,455 increase in budgetary expenses is comprised of a \$150,000 increase for the Inter-Terminal Walkway; a net \$2,500,000 increase and name change for federally funded airfield capital improvement projects; \$50,000 increase for cost increases in ground service equipment (GSE) fuel held for sale and use by Luxivair-SBD; a \$98,455 increase for airport aircraft rescue and fire-fighting services; and three zero dollar department and/or Budget Class budget transfers to fund various projects or anticipated expenses.

Staff identified the following budget classes that require modification. They are described in the table below:

**SAN BERNARDINO INTERNATIONAL AIRPORT AUTHORITY**  
**FY 2025-2026 Proposed Budget Adjustments**  
**April 2026**

**PROPOSED BUDGET ADJUSTMENTS TABLE**

Proposed Adjustments	Budget Class	Approved Budget	Proposed Adjustments	Adjusted Budget
<i>Expenditures &amp; Transfers Out</i>				
<b>A</b>	Development 63 - Project - 25s060-01 Inter-Terminal Walkway	-	150,000	150,000
<b>B</b>	Development 63 - Project - FAA2601-Prelim. Engineering Taxiway C	400,000	(400,000)	-
<b>B</b>	Development 63 - Project - FAA2601-Taxiway C Reconstruction	1,000,000	(1,000,000)	-
<b>C</b>	Development 63 - Project - FAA2601-Prelim. Engineering N. Ramp	-	400,000	400,000
<b>C</b>	Development 63 - Project - FAA2601-Reconstruct North Ramp	-	3,500,000	3,500,000
<b>E</b>	Luxivair-SBD 56 - Parts and Supplies (GSE Fuel)	260,000	50,000	310,000
<b>F</b>	Airport Manager 55 - Maintenance and Repairs	1,912,144	(10,000)	1,902,144
<b>F</b>	Information Technology 54 - Telecommunications	232,000	10,000	242,000
<b>G</b>	Executive Office 63 - Real Property-Capitalized (NavAids/ATCT/Radar)	250,000	(150,000)	100,000
<b>G</b>	Development 55 - Repairs and Maintenance (Infrastructure; 25s053-01)	182,000	150,000	332,000
<b>H</b>	Executive Office 63 - Real Property-Capitalized (NavAids/ATCT/Radar)	250,000	(20,000)	230,000
<b>H</b>	Development 63 - Real Property-Capitalized (Facilities; 25s050-01)	6,869,681	20,000	6,889,681
<b>I</b>	Airport Manager 57 - Other Expenses and Expenditures (ARFF Services)	1,300,000	98,455	1,398,455
			2,798,455	
Increase (Decrease) in expenditures & transfers out			2,798,455	
<i>Revenues &amp; Transfers In</i>				
<b>A</b>	Development 49 - Grant Revenues (Local Grant from SBCO)	-	250,000	250,000
<b>B</b>	Development 49 - Grant Revenues (Federal FAAs2601 - North Ramp)	-	2,250,000	2,250,000
<b>D</b>	Property Management 44 - Land & Non-Terminal Facility Leases and Licenses	14,615,452	205,457	14,820,909
<b>E</b>	Luxivair-SBD 42 - Jet A Cost of Goods Sold (Inventory Purchases)	(70,300,000)	(20,000,000)	(90,300,000)
<b>E</b>	Luxivair-SBD 42 - Jet A Sales	71,200,000	20,000,000	91,200,000
			2,705,457	
Increase (Decrease) in revenues & transfers in			2,705,457	
Net Budget Adjustment, Expenses and Capital Outlay in Excess of Revenue			\$ (92,998)	

- A** \$150,000 increase for the Inter-Terminal Walkway project was funded by a \$250,000 San Bernardino County Fifth District capital improvements grant. The grant requirements include two projects, the Inter-Terminal Walkway and Domestic Terminal Video Display Wall. The Inter-Terminal Walkway will enhance the safety and way finding for SBD pedestrian patrons moving between the Domestic and International Terminals (NTE of \$150,000.) The Domestic Terminal Video Display Wall project is located in the baggage area and was completed for \$172,233.40 in December 2025, with \$120,563.38 of the capital outlay occurring in FY 2025-26.
- B** \$1,400,000 decrease in budget authority and project title change for the Taxiway C Reconstruction (Project No. FAAs2601) project to transfer to the higher priority Capital Improvement Projects for the Reconstruction of the North Ramp project (Project No. FAAs2601).

- C** \$250,000 net increase in the capital improvement project budget for Project FAAs2601 - Reconstruction of North Aircraft Ramp comprised estimated project expenditures of \$400,000 (Preliminary Engineering) and \$3,500,000 (Construction and Construction Management) for an estimated total project cost of \$3,900,000; and estimated federal grant revenues of \$3,510,000 plus match funds of \$390,000 for total sources of \$3,900,000.
- D** \$205,457 increase in new lease revenue for FY 2025-26 from an amendment of the Building 747 lease.
- E** \$50,000 increase in cost of fuel for ground service equipment (GSE) and Luxivair-SBD vehicles that is offset, in part, by a \$25,000 increase in the sales price of GSE fuel to SBD customers and tenants. Zero-dollar net change in Jet A inventory purchases for resale due to increased cost of fuel. The increased purchase price is offset by increased sale price.
- F** Zero-dollar net change of offsetting transfers of budget between the Airport Manager (\$10,000 decrease) and Information Technology (\$10,000 increase) departments to increase the Budget Class 54 - Telecommunications budget to compensate for the change from wired to wireless alarm systems in SBD buildings and structures that in the long-term, will pay for the technology change and reduce operating costs.
- G** Zero-dollar net change of offsetting transfers of budget between the Executive Office (\$150,000 decrease, Budget Class 63) and Development (\$150,000 increase, Budget Class 55) departments provide budget to repair the GA ramp area between Hangar 341 and Hangar 344 to provide an improved surface on which to park aircraft.
- H** Zero-dollar net change of offsetting transfers of budget between the Executive Office (\$20,000 decrease, Budget Class 63) and Development (\$20,000 increase, Budget Class 63) departments to fund Change Order No. 1 of the construction contract for the Service Pit and Canopy project (25s050-01).
- I** \$98,455 increase for aircraft rescue and firefighting services (ARFF) services contract with the San Bernardino County Fire Protection District because the final contract amount was not available at the time the SBIAA budget was approved.

Staff recommend that the Commission approve the above recommended action.

**Attachments:**

1. None

	<p><b>TO: San Bernardino International Airport Authority Commission</b></p> <p><b>DATE: April 22, 2026</b></p> <p><b>ITEM NO: 8</b></p> <p><b>PRESENTER: Scott Huber, Legal Counsel</b></p>
---	---

**SUBJECT: CONSIDER AND DISCUSS A REPORT ON AIRPORT RULES AND REGULATIONS**

**SUMMARY**

From time to time, it is useful for Airport Commissioners to receive information about some of the more unique aspects in the airport and aviation industry as it pertains to operations, compliance, and policy.

**RECOMMENDED ACTION(S)**

Consider and Discuss a Report on Airport Rules and Regulations.

**FISCAL IMPACT**

None.

PREPARED BY:	Jillian Ubaldo
CERTIFIED AS TO AVAILABILITY OF FUNDS:	N/A
APPROVED AS TO FORM AND LEGAL CONTENT:	Scott Huber
FINAL APPROVAL:	Michael Burrows

**BACKGROUND INFORMATION**

A presentation and discussion will be provided at the time of the meeting.

**Attachments:**

1. None

	<p><b>TO: San Bernardino International Airport Authority Commission</b></p> <p><b>DATE: April 22, 2026</b></p> <p><b>ITEM NO: 9</b></p> <p><b>PRESENTER: Scott Huber, Legal Counsel</b></p>
---	---

**SUBJECT: ADOPTION OF RESOLUTION NO. 2026-02 ESTABLISHING THE EXECUTIVE COMMITTEE AS A STANDING COMMITTEE AND ADOPTING A REGULAR MEETING SCHEDULE**

**SUMMARY**

At the regular meeting held on March 25, 2026, the San Bernardino International Airport Authority (SBIAA) Commission voted 4-2 to formalize the Executive Committee as a Standing Committee. This action establishes a permanent role for the Executive Committee to operate under a formal meeting schedule and adhere to all applicable public meeting requirements.

**RECOMMENDED ACTION(S)**

Staff recommends that the Commission adopt Resolution No. 2026-02 formally establishing the Executive Committee as a Standing Committee and approve a regular meeting schedule for the fourth Wednesday of every month, with meetings commencing at 4:00 p.m., except for those months where the Finance and Budget Committee is regularly scheduled, in which case the Executive Committee shall meet at 3:00 p.m.

**FISCAL IMPACT**

None.

PREPARED BY:	Jillian Ubaldo
CERTIFIED AS TO AVAILABILITY OF FUNDS:	N/A
APPROVED AS TO FORM AND LEGAL CONTENT:	Scott Huber
FINAL APPROVAL:	Michael Burrows

**BACKGROUND INFORMATION**

The Executive Committee previously functioned as an "ad hoc" body, or temporary advisory body. Under the Ralph M. Brown Act, ad hoc committees are generally exempt from public notice requirements if they are composed of less than a quorum and have a limited, narrow scope. At the regular meeting held on March 25, 2026, the Commission considered the formalization of this body and, following discussion, voted 4-2 to approve the transition to a Standing Committee. By formal action of the Commission to establish a recurring meeting schedule, the committee is now legally classified as a Standing Committee. This status necessitates full Brown Act compliance, including the requirements to post agendas at least 72 hours in advance, hold meetings in locations accessible to the public, and provide an opportunity for public comment.

The Executive Committee's monthly schedule on the fourth Wednesday is coordinated with the existing SBIAA Finance and Budget Committee schedule to ensure administrative efficiency. Per Resolution No. 2023-05, the Finance and Budget Committee meets quarterly in January, April, August, and October at 4:00 p.m. To accommodate these proceedings, the Executive Committee will meet at 3:00 p.m. during those specific months. For all other months, the Executive Committee will meet at 4:00 p.m. to occur directly before the regular Commission meeting. This alternating schedule ensures consistent administrative review directly preceding each regular Commission meeting.

**Attachments:**

1. SBIAA Resolution No. 2026-02
2. SBIAA Resolution No. 2023-05

**RESOLUTION NO. 2026-02**

**RESOLUTION OF THE SAN BERNARDINO INTERNATIONAL AIRPORT AUTHORITY (SBIAA) ESTABLISHING THE EXECUTIVE COMMITTEE AS A STANDING COMMITTEE AND ADOPTING A REGULAR MEETING SCHEDULE**

**WHEREAS**, the San Bernardino International Airport Authority (the “SBIAA”) is a governmental entity duly organized and existing as a joint powers authority pursuant to Government Code Section 6500, et seq., and the SBIAA was established to own and operate the aviation facilities, hangars, fixed base operator facilities, and other aviation related properties (collectively, “Aviation Facilities”) located upon the former Norton Air Force Base within the City of San Bernardino; and

**WHEREAS**, the Executive Committee previously functioned as an “ad hoc” body, or temporary advisory body; and

**WHEREAS**, at the regular meeting held on March 25, 2026, the SBIAA Commission considered the formalization of this body to improve administrative efficiency and voted 4-2 to approve the transition to a Standing Committee; and

**WHEREAS**, the establishment of a recurring meeting schedule legally classifies the committee as a Standing Committee, necessitating full compliance with the Ralph M. Brown Act, including requirements for public notice, accessible meeting locations, and opportunities for public comment; and

**WHEREAS**, the SBIAA Commission deems it reasonable and appropriate to coordinate the Executive Committee’s schedule with the existing Finance and Budget Committee schedule to ensure administrative efficiency.

**NOW, THEREFORE, BE IT RESOLVED BY THE GOVERNING COMMISSION OF THE SAN BERNARDINO INTERNATIONAL AIRPORT AUTHORITY AS FOLLOWS:**

**SECTION 1**    Recitals. The above Recitals are true and correct and are incorporated herein by this reference.

**SECTION 2**    Establishment of Standing Committee. The SBIAA Executive Committee is hereby formally established as a Standing Committee of the SBIAA Commission.

**SECTION 3** Date, Time and Location of Regular Meetings. The governing Commission of the SBIAA hereby fixes and designates the date, time, and location of the regular meetings of the SBIAA Executive Committee as follows:

**DATE:** Fourth (4<sup>th</sup>) Wednesday of every month

**TIME:** **4:00 p.m.**, except for those months where the Finance and Budget Committee is regularly scheduled (January, April, August, and October), in which case the Executive Committee shall meet at **3:00 p.m.**

**LOCATION:** Norton Regional Event Center  
1601 E. Third Street  
San Bernardino, CA 92408

**SECTION 5** Responsibility. The Assistant Secretary of the Commission shall certify to the passage and adoption of this resolution and enter it into the book of original resolutions.

**SECTION 6** Effective Date. This Resolution shall take effect upon the date of its adoption.

**[SIGNATURES ON FOLLOWING PAGE]**

The foregoing Resolution was PASSED, APPROVED AND ADOPTED this 22nd day of April, 2026 by the following vote:

**MOTION:**

**SECOND:**

**AYES:**

**NOES:**

**ABSENT:**

**ABSTAIN:**

---

Penny Lilburn, President  
San Bernardino International Airport Authority

(SEAL)

Attest:

---

Jillian Ubaldo, Assistant Secretary of the Commission  
San Bernardino International Airport Authority

I, Jillian Ubaldo, Assistant Secretary of the Commission of the San Bernardino International Airport Authority ("SBIAA"), do hereby certify that the foregoing Resolution No. 2026-02 was duly and regularly passed and adopted by the SBIAA Commission at a regular meeting thereof, held on the 22nd day of April, 2026, and that the foregoing is a full, true and correct copy of said Resolution and has not been amended or repealed.

(SEAL)

Attest:

---

Jillian Ubaldo, Assistant Secretary of the Commission  
San Bernardino International Airport Authority

**RESOLUTION NO. 2023-05**

**RESOLUTION OF THE SAN BERNARDINO INTERNATIONAL AIRPORT AUTHORITY (SBIAA) CHANGING THE TIME OF THE REGULAR MEETINGS OF THE SBIAA FINANCE AND BUDGET COMMITTEE AND AMENDING RESOLUTION NO. 2020-02**

**WHEREAS**, the San Bernardino International Airport Authority (the “SBIAA”) is a joint powers authority created pursuant to Government Code Sections 6500, et seq., established in 1992 pursuant to certain Joint Exercise of Powers Agreement creating an Agency To Be Known As The San Bernardino International Airport Authority, dated as May 20, 1992, by and among the County of San Bernardino, the City of Colton, the City of Highland, the City of Loma Linda, and the City of San Bernardino; and

**WHEREAS**, on April 26, 2006, the San Bernardino International Airport Authority (“SBIAA”) Commission approved Resolution No. 2006-01 formally establishing the Finance and Budget Committee; and

**WHEREAS**, on August 9, 2006, the San Bernardino International Airport Authority (“SBIAA”) Commission approved Resolution No. 2006-02 which modified Resolution No. 2006-01 to allow for the appointment of either a primary or an alternate member to the Finance and Budget Committee; and

**WHEREAS**, on December 12, 2012, the San Bernardino International Airport Authority (“SBIAA”) Commission approved Resolution No. 2012-12 which modified Resolution Nos. 2006-01 and 2006-02 changing the date, time, and location of the regular meetings of the SBIAA Finance and Budget Committee; and

**WHEREAS**, on August 26, 2020, the San Bernardino International Airport Authority (“SBIAA”) Commission approved Resolution No. 2020-02 which modified Resolution Nos. 2006-01, 2006-02, and 2012-12 changing one date of the regular meetings of the SBIAA Finance & Budget Committee;

**WHEREAS**, the SBIAA Commission deems it reasonable and appropriate to amend Resolution Nos. 2006-01, 2006-02, 2012-12, and 2020-02 changing the time of the regular meetings of the SBIAA Finance and Budget Committee to 4:00 p.m. every January, April, August, and October.

**NOW THEREFORE, BE IT RESOLVED, DETERMINED AND ORDERED BY THIS BOARD AS THE GOVERNING BODY OF THE SAN BERNARDINO INTERNATIONAL AIRPORT AUTHORITY, AS FOLLOWS:**

SECTION 1. The above Recitals are true and correct and are incorporated herein by this reference.

SECTION 2. The governing Commission of the SBIAA hereby fixes and designates the date, time, and location of the regular meetings of the SBIAA Finance and Budget Committee as follows:

**DATE:** Fourth (4<sup>th</sup>) Wednesday of each of the months of January, April, August, and October

**TIME:** 4:00 p.m.

**LOCATION:** Norton Regional Event Center  
1601 E. Third Street  
San Bernardino, CA 92408

SECTION 3. Resolution Nos. 2012-12, 2006-03, 2006-01 and 2020-02 are hereby amended as set forth above.

SECTION 4. This Resolution shall become effective immediately upon its adoption.

**[SIGNATURES ON FOLLOWING PAGE]**

PASSED, APPROVED AND ADOPTED this 23<sup>rd</sup> day of August 2023 by the following vote:

**MOTION: RIGSBY**

**SECOND: SANCHEZ**

**AYES: LILBURN, NAVARRO, RIGSBY, ROWE, SANCHEZ, TRAN**

**NOES:**

**ABSENT:**

**ABSTAIN:**

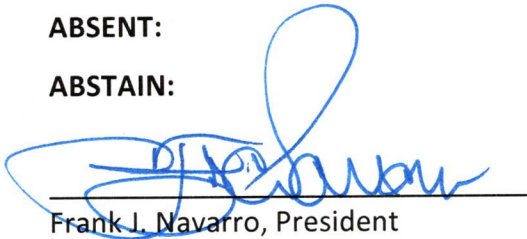

Frank J. Navarro, President  
San Bernardino International Airport Authority

(SEAL)

Attest:



Jennifer Farris, Assistant Secretary of the Commission  
San Bernardino International Airport Authority

I, Jennifer Farris, Assistant Secretary of the Commission of the San Bernardino International Airport Authority (SBIAA) do hereby certify that the foregoing Resolution No. 2023-05 was duly and regularly passed and adopted by the SBIAA governing Commission at a Regular meeting thereof, held on the 23<sup>rd</sup> day of August 2023, that the foregoing is a full, true and correct copy of said Resolution and has not been amended or repealed.

(SEAL)

Attest:



Jennifer Farris, Assistant Secretary of the Commission  
San Bernardino International Airport Authority

	<p><b>TO: San Bernardino International Airport Authority Commission</b></p> <p><b>DATE: April 22, 2026</b></p> <p><b>ITEM NO: 10</b></p> <p><b>PRESENTER: Jeff Barrow, Director of Development</b></p>
---	--

**SUBJECT: AWARD A CONSTRUCTION CONTRACT TO ALL AMERICAN BUILDING SERVICES IN AN AMOUNT NOT TO EXCEED \$131,100 FOR THE INTER-TERMINAL WALKWAY PROJECT**

**SUMMARY**

The award of this construction contract would authorize All American Building Services to construct a walkway connecting the Domestic Terminal to the International Terminal.

**RECOMMENDED ACTION(S)**

Award a construction contract to All American Building Services in an amount not to exceed \$131,100 for the Inter-Terminal Walkway Project; and authorize the Chief Executive Officer to execute all related documents.

**FISCAL IMPACT**

None. In the event that the proposed budget adjustment is approved on today’s agenda, funding for this project will be included in the then adjusted San Bernardino International Airport Authority (SBIAA) Fiscal Year 2025-2026 Budget in Budget Class 63 as a Capital Improvement Project, Capital Improvement Project Number 25s060-1 – Inter-Terminal Walkway for \$150,000 of which \$131,100 is assigned to this construction contract.

PREPARED BY:	Griselda Lizarraga
CERTIFIED AS TO AVAILABILITY OF FUNDS:	Mark Cousineau
APPROVED AS TO FORM AND LEGAL CONTENT:	Scott Huber
FINAL APPROVAL:	Michael Burrows

## **BACKGROUND INFORMATION**

On February 25, 2026, the San Bernardino International Airport Authority (SBIAA) Commission authorized Staff to advertise and solicit construction bids for a new walkway connecting the Domestic Terminal to the International Arrivals Facility Building. Project plans and specifications were publicly advertised, in accordance with SBIAA Policies and Procedures.

The proposed new walkway will create a clear and ADA-compliant path of travel for pedestrian use between the Domestic Terminal and the International Arrivals Facility. The improvements, including a new walkway, crosswalks, and ADA compliant curb, will enhance circulation conditions for SBD passengers, accommodating their needs and ensuring a safe connection between the two terminals. This project aligns with SBIAA's commitment to providing a safe, efficient, and user-friendly experience.

Staff solicited proposals from qualified contractors via PlanetBids. (4) proposals were received, with the full project cost identified below:

- |                                     |              |
|-------------------------------------|--------------|
| • All American Building Services    | \$131,100.00 |
| • Geo Paving and Seal Coating, Inc. | \$149,000.00 |
| • Estate Design and Construction    | \$149,800.00 |
| • Leonida Builders, Inc.            | \$211,760.00 |

SBIAA's standard form construction contract will be used for this project.

Staff recommends the Commission approve the above recommended actions.

### **Attachments:**

1. Work Aerial Map
2. Contractor's Proposals

# WORK AERIAL MAP

Inter-Terminal Walkway Project

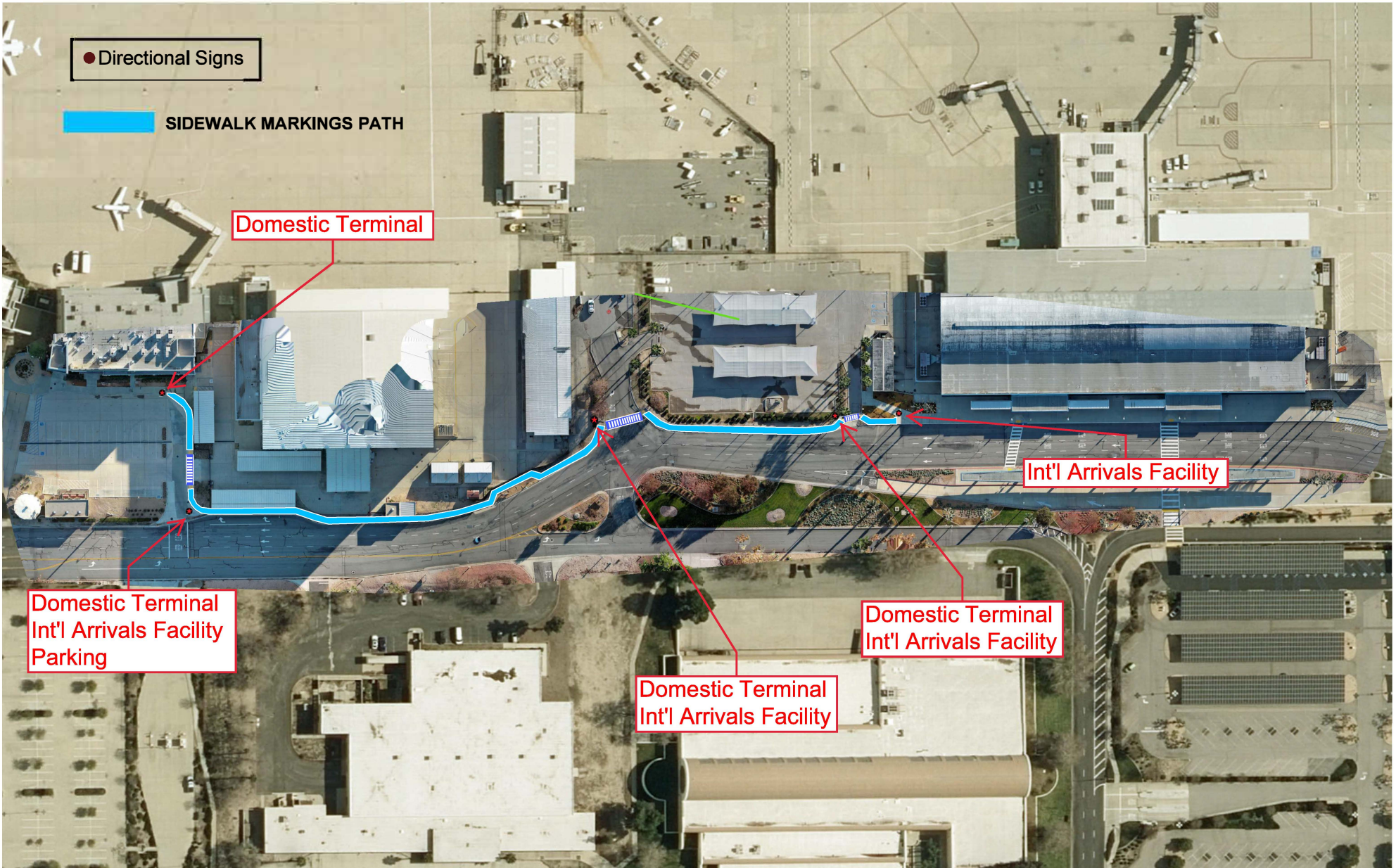

**BID FORM**

**TO:** San Bernardino International Airport Authority, acting by and through its Governing Board, herein called the "AGENCY."

**FROM:** \_\_\_\_\_ All American Building Service  
(Proper Name of Bidder)

1. Pursuant to and in compliance with your Notice Inviting Bids and the other documents relating thereto, the undersigned Bidder, having familiarized himself/herself with the terms of the Contract and the Contract Documents, the environmental permit requirements, the local conditions affecting the performance of the Contract and the cost of the work at the place where the work is to be done, hereby proposes and agrees to perform within the time stipulated, the Work of the Contract, including all of its component parts, and the furnishing of all materials and equipment required to be incorporated in and form a permanent part of the work; the furnishing of tools, equipment, supplies, transportation, utilities, facilities, labor, superintendence and services required to perform and complete the work; bonds, insurance and submittals; and including the assumption of all obligations, duties and responsibilities necessary to the successful completion of the Contract, including its acceptance by the AGENCY.
2. **ADDENDA:** The Contractor shall acknowledge via the PlanetBids website the issuance of all Addenda.
3. **BID SCHEDULE ITEMS:** See next page.

**BID SCHEDULE ITEMS**

SCOPE OF WORK	QTY	UNIT	UNIT COST	FEE
<i>All line items shall be performed in accordance with the Project Scope and Specifications</i>				
<b>BASE BID</b>				
1. TRAFFIC CONTROL	1	LS	2500	2500
2. SIDEWALK PAVEMENT MARKINGS	1,440	SF	35	50,400
3. CONSTRUCT CROSSWALK #1	1	EA	7500	7,500
4. CONSTRUCT CROSSWALKS #2	1	EA	7500	7,500
5. CONSTRUCT CROSSWALK #3	1	EA	7,500	7,500
6. DIRECTIONAL SIGNS	1	LS	8,500	8,500
7. NEW CURB DRAIN	1	LS	11,000	11,000
8. NEW ADA COMPLIANT CONCRETE RAMPS	1	LS	9,200	9,200
<b>BASE BID SUBTOTAL:</b>			104100	
<b>BID ALTERNATE 1</b>				
9. **IN-GROUND SOLAR FLASHING LIGHT SYSTEMS	1	LS	27,000	27,000
<b>BID ALTERNATE SUBTOTAL:</b>			27,700	
<b>GRAND TOTAL:</b>			131,100	

**NOTE: Sidewalk marking SF quantity is an approximated estimate.**

**NOTE: \*\* Indicates possible Bid Alternate Items.**

**INCLUSIONS:**

**The following items are to be made part of the original scope of work, as well as any applicable bid alternates, and must be included in the Contractor's total bid cost.**

- Contractor to provide a dedicated staging area. It is critical to keep the site clean daily as the establishment operates continuously.
- A full submittal package will be required for scope of work items as directed.

**TOTAL AMOUNT OF BASE BID (NOT INCLUDING ALTERNATE ITEMS)**

104,100

---

\$USD (TOTAL BID AMOUNT IN NUMBERS)

One Hundred Four Thousand One Hundred Dollars

---

(TOTAL BID AMOUNT WRITTEN)

**TOTAL AMOUNT OF BID (INCLUDING ALTERNATE ITEMS)**

27,000

---

\$USD (TOTAL BID AMOUNT IN NUMBERS)

Twenty Seven Thousand Dollars

---

(TOTAL BID AMOUNT WRITTEN)

The total of all bid item values listed above must equal the total base bid listed above on Bid Form (written in numbers and words). In the case of a discrepancy between mathematical calculations listed in the bid items and the actual total, the amount shown in Bid Amounts shall govern for the basis of determining low bidder.

The undersigned Bidder agrees to achieve Final Completion of the Work and all Major Milestones within the Contract Time set forth in the Contract Documents.

4. **TIME FOR COMPLETION:** The entire Project shall be completed within **30 consecutive calendar days**. Bidder acknowledges liability for liquidated damages in the amount as stipulated herein for each calendar day of delay.
5. **AGENCY'S RIGHT TO REJECT:** It is understood that the AGENCY reserves the right to reject this bid and that the bid shall remain open to acceptance and is irrevocable for a period of **one hundred and twenty (120) days**.
6. **PROPOSED SUBCONTRACTORS:** The required list of proposed subcontractors is attached hereto. Bidder understands and acknowledges that all subcontractors providing goods and services in excess of \$100,000.00 must be bonded in accordance with the Subletting and Subcontracting Fair Practices Act.
7. **NONCOLLUSION AFFIDAVIT:** The required notarized Bidder's Noncollusion Affidavit is attached hereto.

8. **CONTRACTOR INFORMATION SHEETS:** The required Contractor Information Sheets are attached hereto.
9. **CRIMINAL BACKGROUND CHECK CERTIFICATION:** The required Criminal Background Check Certification will be submitted prior to Contractor commencing work on the project (only if requested) in accordance with the Notice Inviting Bids.
10. **FAITHFUL PERFORMANCE & PAYMENT BONDS:** It is understood and agreed that if Bidder is providing goods and services in excess of \$25,000.00 and written notice of the acceptance of this bid is mailed or delivered to the undersigned after the opening of the bid, and within the time this bid is required to remain open, or at any time thereafter before this bid is withdrawn, the undersigned will execute and deliver to the AGENCY a fully executed Form of Agreement (Contract) in the form attached hereto in accordance with the bid as accepted, and that it will also furnish and deliver to the AGENCY three (3) executed copies of a Faithful Performance Bond and a separate Payment Bond as specified, and certificates of insurance, all within ten (10) calendar days after receipt of notification of the acceptance . The performance bond and payment bond must be obtained from sureties listed on the Department of the Treasury's Circular 570 approved list.

Bidder further agrees that the work under the Contract will be commenced by the Bidder, if awarded the Contract, on the date to be stated in the AGENCY's "Notice to Proceed" and will be completed within the time specified in the Contract documents.

11. **PROPER ADDRESS:** Notice of Award of Contract or other correspondence should be addressed to the undersigned at the address stated below.

PO Box 802586 , Santa Clarita , California , 91380

---

---

12. **NAME(S) OF PRINCIPALS:** Principals of the Bidder's company are:

Anthony Innabi

---

---

---

---

---



hold harmless and defend the AGENCY against any and all actions , proceedings, penalties or claims arising out of the bidder's failure to comply strictly with the IRCA.

17. FINANCIAL STATEMENTS: It is understood and agreed that if requested by the AGENCY, the Bidder will furnish a notarized financial statement, references and other information required by the AGENCY sufficiently comprehensive to permit an appraisal of bidder's ability to perform the work of the Contract.
18. LIQUIDATED DAMAGES: The undersigned hereby warrants that all work shall be completed within **30 consecutive calendar days** from the date specified on the Notice to Proceed issued by the AGENCY. Time is of the essence. The undersigned agrees that failure to complete the work or any scheduled activity within the time set forth herein will result in the imposition of liquidated damages for each consecutive calendar day of delay in the amount of **\$500/calendar day**.
19. CHANGE ORDER REQUESTS: Bidder understands and agrees that all change order requests must be submitted in the form set forth in the Contract Documents. The amount of allowable charges submitted pursuant to a change order shall be limited to the charges allowed by the Conditions of the Contract. Indirect costs, consequential and incidental costs, project management costs, extended home office and field office overhead, administrative costs and profit and other charges not specifically authorized by the Contract Conditions will not be allowed.
20. NOTICE REQUIRED BY DEPARTMENT OF INDUSTRIAL RELATIONS: As of January 1, 2015, the call for bids and contract documents for public improvement project must include the following information:

No contractor or subcontractor may be listed on a bid proposal for a public works project (submitted on or after March 1, 2015) unless registered with the Department of Industrial Relations pursuant to Labor Code section 1725.5 [with limited exceptions from this requirement for bid purposes only under Labor Code section 1771.1(a)].

No contractor or subcontractor may be awarded a contract for public work on a public works project (awarded on or after April 1, 2015) unless registered with the Department of Industrial Relations pursuant to Labor Code section 1725.5.

This project is subject to compliance monitoring and enforcement by the Department of Industrial Relations.

**The following documents must be submitted with this Bid Form.**

1. Bidder's Noncollusion Affidavit
2. Contractor Information Sheets
3. Proposed Subcontractors
4. Bidder References and Responsibility Information

The undersigned declares and certifies under penalty of perjury under the laws of the State of California that the foregoing is true and correct.

All American Building Service

\_\_\_\_\_  
Name of Corporation, Partnership or Sole Proprietor

PO Box 802586 , Santa Clarita , CA , 91380 Tel : (909) 368 0773

\_\_\_\_\_  
Address & Telephone

Anthony Innabi

\_\_\_\_\_  
Proper Name of Bidder Empowered to Sign on Behalf of the Corporation, Partnership or Sole Proprietor

*Anthony Innabi*

\_\_\_\_\_  
Signature of Bidder

NOTE: If bidder is a corporation, the legal name of the corporation shall be set forth above together with the signature of authorized officers or agents and the document shall bear the corporate seal; if bidder is a partnership, the true name of the firm shall be set forth above together with the signature of the partner or partners authorized to sign contracts on behalf of the partnership; and if bidder is an individual, his or her name and signature shall be placed above.

**BID FORM**

**TO:** San Bernardino International Airport Authority, acting by and through its Governing Board, herein called the "AGENCY."

**FROM:** Geo Paving and Seal Coating

---

(Proper Name of Bidder)

1. Pursuant to and in compliance with your Notice Inviting Bids and the other documents relating thereto, the undersigned Bidder, having familiarized himself/herself with the terms of the Contract and the Contract Documents, the environmental permit requirements, the local conditions affecting the performance of the Contract and the cost of the work at the place where the work is to be done, hereby proposes and agrees to perform within the time stipulated, the Work of the Contract, including all of its component parts, and the furnishing of all materials and equipment required to be incorporated in and form a permanent part of the work; the furnishing of tools, equipment, supplies, transportation, utilities, facilities, labor, superintendence and services required to perform and complete the work; bonds, insurance and submittals; and including the assumption of all obligations, duties and responsibilities necessary to the successful completion of the Contract, including its acceptance by the AGENCY.
2. ADDENDA: The Contractor shall acknowledge via the PlanetBids website the issuance of all Addenda.
3. BID SCHEDULE ITEMS: See next page.

**BID SCHEDULE ITEMS**

SCOPE OF WORK	QTY	UNIT	UNIT COST	FEE
<i>All line items shall be performed in accordance with the Project Scope and Specifications</i>				
<b>BASE BID</b>				
1. TRAFFIC CONTROL	1	LS		
2. SIDEWALK PAVEMENT MARKINGS	1,440	SF		
3. CONSTRUCT CROSSWALK #1	1	EA		
4. CONSTRUCT CROSSWALKS #2	1	EA		
5. CONSTRUCT CROSSWALK #3	1	EA		
6. DIRECTIONAL SIGNS	1	LS		
7. NEW CURB DRAIN	1	LS		
8. NEW ADA COMPLIANT CONCRETE RAMPS	1	LS		
<b>BASE BID SUBTOTAL:</b>			\$121,000.00	
<b>BID ALTERNATE 1</b>				
9. **IN-GROUND SOLAR FLASHING LIGHT SYSTEMS	1	LS		
<b>BID ALTERNATE SUBTOTAL:</b>			\$28,000.00	
<b>GRAND TOTAL:</b>			\$149,000.00	

**NOTE: Sidewalk marking SF quantity is an approximated estimate.**

**NOTE: \*\* Indicates possible Bid Alternate Items.**

**INCLUSIONS:**

**The following items are to be made part of the original scope of work, as well as any applicable bid alternates, and must be included in the Contractor's total bid cost.**

- Contractor to provide a dedicated staging area. It is critical to keep the site clean daily as the establishment operates continuously.
- A full submittal package will be required for scope of work items as directed.

**TOTAL AMOUNT OF BASE BID (NOT INCLUDING ALTERNATE ITEMS)**

\$121,000

\_\_\_\_\_  
\$USD (TOTAL BID AMOUNT IN NUMBERS)

One hundred twenty one thousand dollars and 00/100

\_\_\_\_\_  
(TOTAL BID AMOUNT WRITTEN)

**TOTAL AMOUNT OF BID (INCLUDING ALTERNATE ITEMS)**

\$28,000

\_\_\_\_\_  
\$USD (TOTAL BID AMOUNT IN NUMBERS)

One Hundred Thirty-Eight Thousand Dollars and 00/100

\_\_\_\_\_  
(TOTAL BID AMOUNT WRITTEN)

The total of all bid item values listed above must equal the total base bid listed above on Bid Form (written in numbers and words). In the case of a discrepancy between mathematical calculations listed in the bid items and the actual total, the amount shown in Bid Amounts shall govern for the basis of determining low bidder.

The undersigned Bidder agrees to achieve Final Completion of the Work and all Major Milestones within the Contract Time set forth in the Contract Documents.

4. **TIME FOR COMPLETION**: The entire Project shall be completed within **30 consecutive calendar days**. Bidder acknowledges liability for liquidated damages in the amount as stipulated herein for each calendar day of delay.
5. **AGENCY'S RIGHT TO REJECT**: It is understood that the AGENCY reserves the right to reject this bid and that the bid shall remain open to acceptance and is irrevocable for a period of **one hundred and twenty (120) days**.
6. **PROPOSED SUBCONTRACTORS**: The required list of proposed subcontractors is attached hereto. Bidder understands and acknowledges that all subcontractors providing goods and services in excess of \$100,000.00 must be bonded in accordance with the Subletting and Subcontracting Fair Practices Act.
7. **NONCOLLUSION AFFIDAVIT**: The required notarized Bidder's Noncollusion Affidavit is attached hereto.

8. **CONTRACTOR INFORMATION SHEETS:** The required Contractor Information Sheets are attached hereto.
  
9. **CRIMINAL BACKGROUND CHECK CERTIFICATION:** The required Criminal Background Check Certification will be submitted prior to Contractor commencing work on the project (only if requested) in accordance with the Notice Inviting Bids.
  
10. **FAITHFUL PERFORMANCE & PAYMENT BONDS:** It is understood and agreed that if Bidder is providing goods and services in excess of \$25,000.00 and written notice of the acceptance of this bid is mailed or delivered to the undersigned after the opening of the bid, and within the time this bid is required to remain open, or at any time thereafter before this bid is withdrawn, the undersigned will execute and deliver to the AGENCY a fully executed Form of Agreement (Contract) in the form attached hereto in accordance with the bid as accepted, and that it will also furnish and deliver to the AGENCY three (3) executed copies of a Faithful Performance Bond and a separate Payment Bond as specified, and certificates of insurance, all within ten (10) calendar days after receipt of notification of the acceptance . The performance bond and payment bond must be obtained from sureties listed on the Department of the Treasury's Circular 570 approved list.

Bidder further agrees that the work under the Contract will be commenced by the Bidder, if awarded the Contract, on the date to be stated in the AGENCY's "Notice to Proceed" and will be completed within the time specified in the Contract documents.

11. **PROPER ADDRESS:** Notice of Award of Contract or other correspondence should be addressed to the undersigned at the address stated below.

9650 Business Center Dr. Suite 122 Rancho Cucamonga CA 91730  
\_\_\_\_\_  
\_\_\_\_\_

12. **NAME(S) OF PRINCIPALS:** Principals of the Bidder's company are:

Kal Sayegh - Owner  
\_\_\_\_\_  
\_\_\_\_\_  
\_\_\_\_\_  
\_\_\_\_\_



hold harmless and defend the AGENCY against any and all actions , proceedings, penalties or claims arising out of the bidder's failure to comply strictly with the IRCA.

17. FINANCIAL STATEMENTS: It is understood and agreed that if requested by the AGENCY, the Bidder will furnish a notarized financial statement, references and other information required by the AGENCY sufficiently comprehensive to permit an appraisal of bidder's ability to perform the work of the Contract.
18. LIQUIDATED DAMAGES: The undersigned hereby warrants that all work shall be completed within **30 consecutive calendar days** from the date specified on the Notice to Proceed issued by the AGENCY. Time is of the essence. The undersigned agrees that failure to complete the work or any scheduled activity within the time set forth herein will result in the imposition of liquidated damages for each consecutive calendar day of delay in the amount of **\$500/calendar day**.
19. CHANGE ORDER REQUESTS: Bidder understands and agrees that all change order requests must be submitted in the form set forth in the Contract Documents. The amount of allowable charges submitted pursuant to a change order shall be limited to the charges allowed by the Conditions of the Contract. Indirect costs, consequential and incidental costs, project management costs, extended home office and field office overhead, administrative costs and profit and other charges not specifically authorized by the Contract Conditions will not be allowed.
20. NOTICE REQUIRED BY DEPARTMENT OF INDUSTRIAL RELATIONS: As of January 1, 2015, the call for bids and contract documents for public improvement project must include the following information:

No contractor or subcontractor may be listed on a bid proposal for a public works project (submitted on or after March 1, 2015) unless registered with the Department of Industrial Relations pursuant to Labor Code section 1725.5 [with limited exceptions from this requirement for bid purposes only under Labor Code section 1771.1(a)].

No contractor or subcontractor may be awarded a contract for public work on a public works project (awarded on or after April 1, 2015) unless registered with the Department of Industrial Relations pursuant to Labor Code section 1725.5.

This project is subject to compliance monitoring and enforcement by the Department of Industrial Relations.

**The following documents must be submitted with this Bid Form.**

1. Bidder's Noncollusion Affidavit
2. Contractor Information Sheets
3. Proposed Subcontractors
4. Bidder References and Responsibility Information

The undersigned declares and certifies under penalty of perjury under the laws of the State of California that the foregoing is true and correct.

Geo Paving and Seal Coating

\_\_\_\_\_  
Name of Corporation, Partnership or Sole Proprietor

9650 Business Center Dr. Suite 122 Rancho Cucamonga, CA 91730

\_\_\_\_\_  
Address & Telephone

Kal Sayegh 951-463-7002

\_\_\_\_\_  
Proper Name of Bidder Empowered to Sign on Behalf of the Corporation, Partnership or Sole Proprietor



\_\_\_\_\_  
Signature of Bidder

NOTE: If bidder is a corporation, the legal name of the corporation shall be set forth above together with the signature of authorized officers or agents and the document shall bear the corporate seal; if bidder is a partnership, the true name of the firm shall be set forth above together with the signature of the partner or partners authorized to sign contracts on behalf of the partnership; and if bidder is an individual, his or her name and signature shall be placed above.

**BID FORM**

**TO:** San Bernardino International Airport Authority, acting by and through its Governing Board, herein called the "AGENCY."

**FROM:** Estate Design and Construction  
(Proper Name of Bidder)

1. Pursuant to and in compliance with your Notice Inviting Bids and the other documents relating thereto, the undersigned Bidder, having familiarized himself/herself with the terms of the Contract and the Contract Documents, the environmental permit requirements, the local conditions affecting the performance of the Contract and the cost of the work at the place where the work is to be done, hereby proposes and agrees to perform within the time stipulated, the Work of the Contract, including all of its component parts, and the furnishing of all materials and equipment required to be incorporated in and form a permanent part of the work; the furnishing of tools, equipment, supplies, transportation, utilities, facilities, labor, superintendence and services required to perform and complete the work; bonds, insurance and submittals; and including the assumption of all obligations, duties and responsibilities necessary to the successful completion of the Contract, including its acceptance by the AGENCY.
2. ADDENDA: The Contractor shall acknowledge via the PlanetBids website the issuance of all Addenda.
3. BID SCHEDULE ITEMS: See next page.

**BID SCHEDULE ITEMS**

SCOPE OF WORK	QTY	UNIT	UNIT COST	FEE
<i>All line items shall be performed in accordance with the Project Scope and Specifications</i>				
<b>BASE BID</b>				
1. TRAFFIC CONTROL	1	LS	\$ 12,000.00	\$ 12,000.00
2. SIDEWALK PAVEMENT MARKINGS	1,440	SF	\$ 14.40	\$ 20,736.00
3. CONSTRUCT CROSSWALK #1	1	EA	\$ 7,800.00	\$ 7,800.00
4. CONSTRUCT CROSSWALKS #2	1	EA	\$ 3,300.00	\$ 3,300.00
5. CONSTRUCT CROSSWALK #3	1	EA	\$ 4,200.00	\$ 4,200.00
6. DIRECTIONAL SIGNS	1	LS	\$ 6,960.00	\$ 6,960.00
7. NEW CURB DRAIN	1	LS	\$ 8,520.00	\$ 8,520.00
8. NEW ADA COMPLIANT CONCRETE RAMPS	1	LS	\$ 60,720.00	\$ 60,720.00
<b>BASE BID SUBTOTAL:</b>			<b>\$ 124,236.00</b>	
<b>BID ALTERNATE 1</b>				
9. **IN-GROUND SOLAR FLASHING LIGHT SYSTEMS	1	LS	\$ 25,564.00	\$ 25,564.00
<b>BID ALTERNATE SUBTOTAL:</b>			<b>\$ 25,564.00</b>	
<b>GRAND TOTAL:</b>			<b>\$ 149,800.00</b>	

**NOTE: Sidewalk marking SF quantity is an approximated estimate.**

**NOTE: \*\* Indicates possible Bid Alternate Items.**

**INCLUSIONS:**

**The following items are to be made part of the original scope of work, as well as any applicable bid alternates, and must be included in the Contractor's total bid cost.**

- Contractor to provide a dedicated staging area. It is critical to keep the site clean daily as the establishment operates continuously.
- A full submittal package will be required for scope of work items as directed.

**TOTAL AMOUNT OF BASE BID (NOT INCLUDING ALTERNATE ITEMS)**

**\$ 124,236.00**

---

\$USD (TOTAL BID AMOUNT IN NUMBERS)

**One Hundred Twenty-Four Thousand Two Hundred Thirty-Six Dollars**

---

(TOTAL BID AMOUNT WRITTEN)

**TOTAL AMOUNT OF BID (INCLUDING ALTERNATE ITEMS)**

**\$ 149,800.00**

---

\$USD (TOTAL BID AMOUNT IN NUMBERS)

**One Hundred Forty-Nine Thousand Eight Hundred Dollars**

---

(TOTAL BID AMOUNT WRITTEN)

The total of all bid item values listed above must equal the total base bid listed above on Bid Form (written in numbers and words). In the case of a discrepancy between mathematical calculations listed in the bid items and the actual total, the amount shown in Bid Amounts shall govern for the basis of determining low bidder.

The undersigned Bidder agrees to achieve Final Completion of the Work and all Major Milestones within the Contract Time set forth in the Contract Documents.

4. TIME FOR COMPLETION: The entire Project shall be completed within **30 consecutive calendar days**. Bidder acknowledges liability for liquidated damages in the amount as stipulated herein for each calendar day of delay.
5. AGENCY'S RIGHT TO REJECT: It is understood that the AGENCY reserves the right to reject this bid and that the bid shall remain open to acceptance and is irrevocable for a period of **one hundred and twenty (120) days**.
6. PROPOSED SUBCONTRACTORS: The required list of proposed subcontractors is attached hereto. Bidder understands and acknowledges that all subcontractors providing goods and services in excess of \$100,000.00 must be bonded in accordance with the Subletting and Subcontracting Fair Practices Act.
7. NONCOLLUSION AFFIDAVIT: The required notarized Bidder's Noncollusion Affidavit is attached hereto.

8. **CONTRACTOR INFORMATION SHEETS:** The required Contractor Information Sheets are attached hereto.
  
9. **CRIMINAL BACKGROUND CHECK CERTIFICATION:** The required Criminal Background Check Certification will be submitted prior to Contractor commencing work on the project (only if requested) in accordance with the Notice Inviting Bids.
  
10. **FAITHFUL PERFORMANCE & PAYMENT BONDS:** It is understood and agreed that if Bidder is providing goods and services in excess of \$25,000.00 and written notice of the acceptance of this bid is mailed or delivered to the undersigned after the opening of the bid, and within the time this bid is required to remain open, or at any time thereafter before this bid is withdrawn, the undersigned will execute and deliver to the AGENCY a fully executed Form of Agreement (Contract) in the form attached hereto in accordance with the bid as accepted, and that it will also furnish and deliver to the AGENCY three (3) executed copies of a Faithful Performance Bond and a separate Payment Bond as specified, and certificates of insurance, all within ten (10) calendar days after receipt of notification of the acceptance . The performance bond and payment bond must be obtained from sureties listed on the Department of the Treasury's Circular 570 approved list.

Bidder further agrees that the work under the Contract will be commenced by the Bidder, if awarded the Contract, on the date to be stated in the AGENCY's "Notice to Proceed" and will be completed within the time specified in the Contract documents.

11. **PROPER ADDRESS:** Notice of Award of Contract or other correspondence should be addressed to the undersigned at the address stated below.

5701 Buckingham Pkwy, UNIT C, Culver City, CA 90230

---

---

12. **NAME(S) OF PRINCIPALS:** Principals of the Bidder's company are:

Benjamin S. Tvizer, CEO

---

---

---

---

---

(IMPORTANT NOTICE: If Bidder is a corporation, state legal name of corporation, as well as names of the president, secretary treasurer, and general manager thereof; if a partnership, state true name of firm, also names of all individual partners composing firm; if an individual, state names in full.)

13. The undersigned bidder declares that the bidder is licensed in the State of California as required by the Business and Professional Code in accordance with the act providing for registration of Contractors and the documentation of licensure is as follows:

<u>License No.</u>	<u>Classification</u>	<u>Expiration Date</u>
1075658	A	09/30/2027
1075658	B	09/30/2027
1075658	C-36	09/30/2027
1075658	C-39	09/30/2027

If the bidder is a joint venture, each member of the joint venture must include the above information Bidder certifies that the above-mentioned license(s) entitle(s) Bidder to provide the work required by the Contract, that such license will be in full force and effect throughout the duration of work under this Contract, and that any and all subcontractors to be employed for the work will have appropriate licenses.

14. **FORFEITURE OF SECURITY:** In the event the Bidder to whom the Notice of Award of Contract is given fails or refuses to post the required bonds and return executed copies of the Form of Agreement with all required attachments within ten (10) calendar days from the date of the Notice of Award, the AGENCY may declare the Bidder's bid deposit or bond forfeited as liquidated damages.
15. **ASSIGNMENT OF RIGHTS, TITLE AND INTEREST IN CAUSES OF ACTION:** Pursuant to Section 4552 of the Government code, in submitting a bid to the AGENCY, the bidder offers and agrees that if the bid is accepted, it will assign to AGENCY all rights, title, and interest in and to all causes of action it may have under Section 4 of the Clayton Act (15 U.S.C. Section 15) or under the Cartwright Act (Chapter 2 (commencing with Section 16700) of Part 2 of Division 7 of the Business and Professions Code), arising from purchases of goods, materials, or services by the bidder for sale to the purchasing body pursuant to the bid. Such assignment shall be made and become effective at the time the purchasing body tenders final payment to the bidder.
16. **IRCA:** The bidder hereby certifies that it is, and at all times during the performance of work hereunder will be, in full compliance with the provisions of the Immigration Reform and Control Act of 1986 ("IRCA") in the hiring of its employees and the bidder shall indemnify,

hold harmless and defend the AGENCY against any and all actions , proceedings, penalties or claims arising out of the bidder's failure to comply strictly with the IRCA.

17. FINANCIAL STATEMENTS: It is understood and agreed that if requested by the AGENCY, the Bidder will furnish a notarized financial statement, references and other information required by the AGENCY sufficiently comprehensive to permit an appraisal of bidder's ability to perform the work of the Contract.
18. LIQUIDATED DAMAGES: The undersigned hereby warrants that all work shall be completed within **30 consecutive calendar days** from the date specified on the Notice to Proceed issued by the AGENCY. Time is of the essence. The undersigned agrees that failure to complete the work or any scheduled activity within the time set forth herein will result in the imposition of liquidated damages for each consecutive calendar day of delay in the amount of **\$500/calendar day**.
19. CHANGE ORDER REQUESTS: Bidder understands and agrees that all change order requests must be submitted in the form set forth in the Contract Documents. The amount of allowable charges submitted pursuant to a change order shall be limited to the charges allowed by the Conditions of the Contract. Indirect costs, consequential and incidental costs, project management costs, extended home office and field office overhead, administrative costs and profit and other charges not specifically authorized by the Contract Conditions will not be allowed.
20. NOTICE REQUIRED BY DEPARTMENT OF INDUSTRIAL RELATIONS: As of January 1, 2015, the call for bids and contract documents for public improvement project must include the following information:

No contractor or subcontractor may be listed on a bid proposal for a public works project (submitted on or after March 1, 2015) unless registered with the Department of Industrial Relations pursuant to Labor Code section 1725.5 [with limited exceptions from this requirement for bid purposes only under Labor Code section 1771.1(a)].

No contractor or subcontractor may be awarded a contract for public work on a public works project (awarded on or after April 1, 2015) unless registered with the Department of Industrial Relations pursuant to Labor Code section 1725.5.

This project is subject to compliance monitoring and enforcement by the Department of Industrial Relations.

**The following documents must be submitted with this Bid Form.**

1. Bidder's Noncollusion Affidavit
2. Contractor Information Sheets
3. Proposed Subcontractors
4. Bidder References and Responsibility Information

The undersigned declares and certifies under penalty of perjury under the laws of the State of California that the foregoing is true and correct.

**Estate Design and Construction**

---

Name of Corporation, Partnership or Sole Proprietor

5701 Buckingham Pkwy, UNIT C, Culver City, CA 90230 / 310-810-7319

---

Address & Telephone

Benjamin S. Tvizer

---

Proper Name of Bidder Empowered to Sign on Behalf of the Corporation, Partnership or Sole Proprietor



---

Signature of Bidder

NOTE: If bidder is a corporation, the legal name of the corporation shall be set forth above together with the signature of authorized officers or agents and the document shall bear the corporate seal; if bidder is a partnership, the true name of the firm shall be set forth above together with the signature of the partner or partners authorized to sign contracts on behalf of the partnership; and if bidder is an individual, his or her name and signature shall be placed above.

**BID FORM**

**TO:** San Bernardino International Airport Authority, acting by and through its Governing Board, herein called the "AGENCY."

**FROM:** Leonida Builders, Inc.

---

(Proper Name of Bidder)

1. Pursuant to and in compliance with your Notice Inviting Bids and the other documents relating thereto, the undersigned Bidder, having familiarized himself/herself with the terms of the Contract and the Contract Documents, the environmental permit requirements, the local conditions affecting the performance of the Contract and the cost of the work at the place where the work is to be done, hereby proposes and agrees to perform within the time stipulated, the Work of the Contract, including all of its component parts, and the furnishing of all materials and equipment required to be incorporated in and form a permanent part of the work; the furnishing of tools, equipment, supplies, transportation, utilities, facilities, labor, superintendence and services required to perform and complete the work; bonds, insurance and submittals; and including the assumption of all obligations, duties and responsibilities necessary to the successful completion of the Contract, including its acceptance by the AGENCY.
2. ADDENDA: The Contractor shall acknowledge via the PlanetBids website the issuance of all Addenda.
3. BID SCHEDULE ITEMS: See next page.

**BID SCHEDULE ITEMS**

SCOPE OF WORK	QTY	UNIT	UNIT COST	FEE
<i>All line items shall be performed in accordance with the Project Scope and Specifications</i>				
<b>BASE BID</b>				
1. TRAFFIC CONTROL	1	LS	5,000.00	5,000.00
2. SIDEWALK PAVEMENT MARKINGS	1,440	SF	14.00	20,160.00
3. CONSTRUCT CROSSWALK #1	1	EA	18,000.00	18,000.00
4. CONSTRUCT CROSSWALKS #2	1	EA	18,000.00	18,000.00
5. CONSTRUCT CROSSWALK #3	1	EA	18,000.00	18,000.00
6. DIRECTIONAL SIGNS	1	LS	12,600.00	12,600.00
7. NEW CURB DRAIN	1	LS	5,000.00	5,000.00
8. NEW ADA COMPLIANT CONCRETE RAMPS	1	LS	25,000.00	25,000.00
<b>BASE BID SUBTOTAL:</b>			121,760.00	
<b>BID ALTERNATE 1</b>				
9. **IN-GROUND SOLAR FLASHING LIGHT SYSTEMS	1	LS	90,000.00	90,000.00
<b>BID ALTERNATE SUBTOTAL:</b>			90,000.00	
<b>GRAND TOTAL:</b>			211,760.00	

**NOTE: Sidewalk marking SF quantity is an approximated estimate.**

**NOTE: \*\* Indicates possible Bid Alternate Items.**

**INCLUSIONS:**

**The following items are to be made part of the original scope of work, as well as any applicable bid alternates, and must be included in the Contractor's total bid cost.**

- Contractor to provide a dedicated staging area. It is critical to keep the site clean daily as the establishment operates continuously.
- A full submittal package will be required for scope of work items as directed.

**TOTAL AMOUNT OF BASE BID (NOT INCLUDING ALTERNATE ITEMS)**

---

\$USD (TOTAL BID AMOUNT IN NUMBERS)

---

(TOTAL BID AMOUNT WRITTEN)

**TOTAL AMOUNT OF BID (INCLUDING ALTERNATE ITEMS)**

---

\$USD (TOTAL BID AMOUNT IN NUMBERS)

---

(TOTAL BID AMOUNT WRITTEN)

The total of all bid item values listed above must equal the total base bid listed above on Bid Form (written in numbers and words). In the case of a discrepancy between mathematical calculations listed in the bid items and the actual total, the amount shown in Bid Amounts shall govern for the basis of determining low bidder.

The undersigned Bidder agrees to achieve Final Completion of the Work and all Major Milestones within the Contract Time set forth in the Contract Documents.

4. **TIME FOR COMPLETION:** The entire Project shall be completed within **30 consecutive calendar days**. Bidder acknowledges liability for liquidated damages in the amount as stipulated herein for each calendar day of delay.
5. **AGENCY'S RIGHT TO REJECT:** It is understood that the AGENCY reserves the right to reject this bid and that the bid shall remain open to acceptance and is irrevocable for a period of **one hundred and twenty (120) days**.
6. **PROPOSED SUBCONTRACTORS:** The required list of proposed subcontractors is attached hereto. Bidder understands and acknowledges that all subcontractors providing goods and services in excess of \$100,000.00 must be bonded in accordance with the Subletting and Subcontracting Fair Practices Act.
7. **NONCOLLUSION AFFIDAVIT:** The required notarized Bidder's Noncollusion Affidavit is attached hereto.

8. **CONTRACTOR INFORMATION SHEETS:** The required Contractor Information Sheets are attached hereto.
  
9. **CRIMINAL BACKGROUND CHECK CERTIFICATION:** The required Criminal Background Check Certification will be submitted prior to Contractor commencing work on the project (only if requested) in accordance with the Notice Inviting Bids.
  
10. **FAITHFUL PERFORMANCE & PAYMENT BONDS:** It is understood and agreed that if Bidder is providing goods and services in excess of \$25,000.00 and written notice of the acceptance of this bid is mailed or delivered to the undersigned after the opening of the bid, and within the time this bid is required to remain open, or at any time thereafter before this bid is withdrawn, the undersigned will execute and deliver to the AGENCY a fully executed Form of Agreement (Contract) in the form attached hereto in accordance with the bid as accepted, and that it will also furnish and deliver to the AGENCY three (3) executed copies of a Faithful Performance Bond and a separate Payment Bond as specified, and certificates of insurance, all within ten (10) calendar days after receipt of notification of the acceptance . The performance bond and payment bond must be obtained from sureties listed on the Department of the Treasury's Circular 570 approved list.

Bidder further agrees that the work under the Contract will be commenced by the Bidder, if awarded the Contract, on the date to be stated in the AGENCY's "Notice to Proceed" and will be completed within the time specified in the Contract documents.

11. **PROPER ADDRESS:** Notice of Award of Contract or other correspondence should be addressed to the undersigned at the address stated below.

32023 Crown Valley Road, Acton CA 93510

---

---

12. **NAME(S) OF PRINCIPALS:** Principals of the Bidder's company are:

Panagiotis Leonida

---

---

---

---

---



hold harmless and defend the AGENCY against any and all actions , proceedings, penalties or claims arising out of the bidder's failure to comply strictly with the IRCA.

17. FINANCIAL STATEMENTS: It is understood and agreed that if requested by the AGENCY, the Bidder will furnish a notarized financial statement, references and other information required by the AGENCY sufficiently comprehensive to permit an appraisal of bidder's ability to perform the work of the Contract.
18. LIQUIDATED DAMAGES: The undersigned hereby warrants that all work shall be completed within **30 consecutive calendar days** from the date specified on the Notice to Proceed issued by the AGENCY. Time is of the essence. The undersigned agrees that failure to complete the work or any scheduled activity within the time set forth herein will result in the imposition of liquidated damages for each consecutive calendar day of delay in the amount of **\$500/calendar day**.
19. CHANGE ORDER REQUESTS: Bidder understands and agrees that all change order requests must be submitted in the form set forth in the Contract Documents. The amount of allowable charges submitted pursuant to a change order shall be limited to the charges allowed by the Conditions of the Contract. Indirect costs, consequential and incidental costs, project management costs, extended home office and field office overhead, administrative costs and profit and other charges not specifically authorized by the Contract Conditions will not be allowed.
20. NOTICE REQUIRED BY DEPARTMENT OF INDUSTRIAL RELATIONS: As of January 1, 2015, the call for bids and contract documents for public improvement project must include the following information:

No contractor or subcontractor may be listed on a bid proposal for a public works project (submitted on or after March 1, 2015) unless registered with the Department of Industrial Relations pursuant to Labor Code section 1725.5 [with limited exceptions from this requirement for bid purposes only under Labor Code section 1771.1(a)].

No contractor or subcontractor may be awarded a contract for public work on a public works project (awarded on or after April 1, 2015) unless registered with the Department of Industrial Relations pursuant to Labor Code section 1725.5.

This project is subject to compliance monitoring and enforcement by the Department of Industrial Relations.

**The following documents must be submitted with this Bid Form.**

1. Bidder's Noncollusion Affidavit
2. Contractor Information Sheets
3. Proposed Subcontractors
4. Bidder References and Responsibility Information

The undersigned declares and certifies under penalty of perjury under the laws of the State of California that the foregoing is true and correct.

Leonida Builders, Inc.

\_\_\_\_\_  
Name of Corporation, Partnership or Sole Proprietor

32023 Crown Valley Road, Acton CA 93510

\_\_\_\_\_  
Address & Telephone

Panagiotis Leonida

\_\_\_\_\_  
Proper Name of Bidder Empowered to Sign on Behalf of the Corporation, Partnership or Sole Proprietor

\_\_\_\_\_  
Signature of Bidder

NOTE: If bidder is a corporation, the legal name of the corporation shall be set forth above together with the signature of authorized officers or agents and the document shall bear the corporate seal; if bidder is a partnership, the true name of the firm shall be set forth above together with the signature of the partner or partners authorized to sign contracts on behalf of the partnership; and if bidder is an individual, his or her name and signature shall be placed above.



	<p><b>TO: San Bernardino International Airport Authority Commission</b></p> <p><b>DATE: April 22, 2026</b></p> <p><b>ITEM NO: 11</b></p> <p><b>PRESENTER: Jeff Barrow, Director of Development</b></p>
---	--

**SUBJECT: AWARD A CONSTRUCTION CONTRACT TO GEO PAVING AND SEAL COATING, INC. IN AN AMOUNT NOT TO EXCEED \$133,500.50 FOR THE GENERAL AVIATION RAMP (PHASE II) PROJECT**

**SUMMARY**

The award of this construction contract would authorize Geo Paving and Seal Coating, Inc. to construct improvements for the general aviation ramp.

**RECOMMENDED ACTION(S)**

Award a construction contract to Geo Paving and Seal Coating, Inc. in an amount not to exceed \$133,500.50 for the General Aviation Ramp (Phase II) Project; and authorize the Chief Executive Officer to execute all related documents.

**FISCAL IMPACT**

None. In the event that the proposed budget adjustment is approved on today’s agenda, funding for this project will be included in the then adjusted San Bernardino International Airport Authority (SBIAA) Fiscal Year 2025-2026 Budget, Budget Class 555, Repairs and Maintenance, Infrastructure, Project Number - 25s053-01 in the amount \$332,000 of which \$133,510 is allocated for this project.

PREPARED BY:	Griselda Lizarraga
CERTIFIED AS TO AVAILABILITY OF FUNDS:	Mark Cousineau
APPROVED AS TO FORM AND LEGAL CONTENT:	Scott Huber
FINAL APPROVAL:	Michael Burrows

## **BACKGROUND INFORMATION**

On February 25, 2026, the San Bernardino International Airport Authority (SBIAA) Commission authorized Staff to advertise and solicit construction bids for construction of ramp improvements along the general aviation hangars. Project plans and specifications were publicly advertised, in accordance with SBIAA Policies and Procedures.

The proposed improvements consist of resurfacing an 89,150 SF area of damaged asphalt along the general aviation hangars. The damaged asphalt will be cleaned and prepped, followed by the application of fog seal and type II slurry seal products. This project will enhance ramp conditions for SBD tenants and staff. This project aligns with SBIAA's commitment to providing a safe, efficient, and user-friendly experience.

Staff solicited proposals from qualified contractors via PlanetBids. (6) proposals were received, with the full project cost identified below:

- Geo Paving and Seal Coating, Inc.      \$133,500.50
- Roy Allan Slurry Seal, Inc.              \$138,745.00
- Riverside Slurry Seal, Inc.              \$142,905.00
- Union Pavement Services, Inc.         \$144,933.00
- All American Building Services        \$232,127.00
- Estate Design and Construction        \$448,500.00

SBIAA's standard form construction contract will be used for this project.

Staff recommends the Commission approve the above recommended actions.

### **Attachments:**

1. Work Aerial Map
2. Contractor's Proposals

# WORK AERIAL MAP



## BID FORM

**TO:** San Bernardino International Airport Authority, acting by and through its Governing Board, herein called the "AGENCY."

**FROM:** Geo Paving and Seal Coating

---

(Proper Name of Bidder)

1. Pursuant to and in compliance with your Notice Inviting Bids and the other documents relating thereto, the undersigned Bidder, having familiarized himself/herself with the terms of the Contract and the Contract Documents, the environmental permit requirements, the local conditions affecting the performance of the Contract and the cost of the work at the place where the work is to be done, hereby proposes and agrees to perform within the time stipulated, the Work of the Contract, including all of its component parts, and the furnishing of all materials and equipment required to be incorporated in and form a permanent part of the work; the furnishing of tools, equipment, supplies, transportation, utilities, facilities, labor, superintendence and services required to perform and complete the work; bonds, insurance and submittals; and including the assumption of all obligations, duties and responsibilities necessary to the successful completion of the Contract, including its acceptance by the AGENCY.
2. ADDENDA: The Contractor shall acknowledge via the PlanetBids website the issuance of all Addenda.
3. BID SCHEDULE ITEMS: See next page.

**BID SCHEDULE ITEMS**

SCOPE OF WORK	QTY	UNIT	UNIT COST	FEE
<i>All line items shall be performed in accordance with the Project Plans, Details, and Specifications</i>				
<b>BASE BID: YELLOW AREA</b>				
1. MOBILIZATION / DEMOBILIZATION (5% MAXIMUM OF BASE BID)	1	LS		
2. CONSTRUCTION SAFETY AND PHASING PLAN (CSPP)	1	LS		
3. HEAVY WASH EXISTING ASPHALT TO GET RID OF LOOSE GRAVEL, ROCKS, AND ALL OTHER DEBRIS	1	LS		
4. PATCH & FILL ALL HOLES AND CRACKS GREATER THAN 6" DEEP WITH HOT ASPHALT	1	LS		
5. SOAK PREPPED SURFACE WITH THICK COAT OF FOG SEAL (BEFORE SLURRY SEAL APPLICATION)	73,150	SF		
6. APPLY (1) THICK COAT OF TYPE II ROAD SLURRY SEAL	73,150	SF		
7. APPLY FINAL THICK COAT OF FOG SEAL (OVER SLURRY SEAL APPLICATION)	73,150	SF		
8. GRIND ALL ASPHALT-TO-CONCRETE INTERFACE SURFACES; TO ACHIEVE SMOOTH / FLUSH TRANSITIONS	1	LS		
9. REMOVE EXISTING AIRPLANE TIE DOWN AND FILL HOLE PER PAVEMENT REPAIR DETAILS PLAN	1	EA		
<b>BASE BID SUBTOTAL:</b>			109,500	
<b>BID ALTERNATE 1: BLUE AREA</b>				
10. **HEAVY WASH EXISTING ASPHALT TO GET RID OF LOOSE GRAVEL, ROCKS, AND ALL OTHER DEBRIS	1	LS		
11. **PATCH & FILL ALL HOLES AND CRACKS GREATER THAN 6" DEEP WITH HOT ASPHALT	1	LS		

12. **SOAK PREPPED SURFACE WITH THICK COAT OF FOG SEAL (BEFORE SLURRY SEAL APPLICATION)	16,000	SF		
13. **APPLY (1) THICK COAT OF TYPE II ROAD SLURRY SEAL	16,000	SF		
14. **APPLY FINAL THICK COAT OF FOG SEAL (OVER SLURRY SEAL APPLICATION)	16,000	SF		
15. **GRIND ALL ASPHALT-TO-CONCRETE INTERFACE SURFACES; TO ACHIEVE SMOOTH / FLUSH TRANSITIONS	1	LS		
<b>BID ALTERNATE 1 SUBTOTAL:</b>			24,000	
<b>GRAND TOTAL:</b>			133,500	

**NOTE: \*\* Indicates possible Bid Alternate Items.**

**INCLUSIONS:**

**The following items are to be made part of the original scope of work, as well as any applicable bid alternates, and must be included in the Contractor's total bid cost.**

- Contractor to provide a dedicated staging area. It is critical to keep the site clean daily as the establishment operates continuously.
- A full submittal package will be required for scope of work items as directed.

**TOTAL AMOUNT OF BASE BID (NOT INCLUDING ALTERNATE ITEMS)**

109,500

\_\_\_\_\_  
 \$USD (TOTAL BID AMOUNT IN NUMBERS)

One hundred five thousand and five hundred dollars

\_\_\_\_\_  
 (TOTAL BID AMOUNT WRITTEN)

**TOTAL AMOUNT OF BID (INCLUDING ALTERNATE ITEMS)**

133,500

\_\_\_\_\_  
 \$USD (TOTAL BID AMOUNT IN NUMBERS)

One hundred thirty three thousand and five hundred dollars

\_\_\_\_\_  
 (TOTAL BID AMOUNT WRITTEN)

The total of all bid item values listed above must equal the total base bid listed above on Bid Form (written in numbers and words). In the case of a discrepancy between mathematical calculations listed in the bid items and the actual total, the amount shown in Bid Amounts shall govern for the basis of determining low bidder.

The undersigned Bidder agrees to achieve Final Completion of the Work and all Major Milestones within the Contract Time set forth in the Contract Documents.

4. TIME FOR COMPLETION: The entire Project shall be completed within **60 consecutive calendar days**. Bidder acknowledges liability for liquidated damages in the amount as stipulated herein for each calendar day of delay.
5. AGENCY'S RIGHT TO REJECT: It is understood that the AGENCY reserves the right to reject this bid and that the bid shall remain open to acceptance and is irrevocable for a period of **one hundred and twenty (120) days**.
6. PROPOSED SUBCONTRACTORS: The required list of proposed subcontractors is attached hereto. Bidder understands and acknowledges that all subcontractors providing goods and services in excess of \$100,000.00 must be bonded in accordance with the Subletting and Subcontracting Fair Practices Act.
7. NONCOLLUSION AFFIDAVIT: The required notarized Bidder's Noncollusion Affidavit is attached hereto.
8. CONTRACTOR INFORMATION SHEETS: The required Contractor Information Sheets are attached hereto.
9. CRIMINAL BACKGROUND CHECK CERTIFICATION: The required Criminal Background Check Certification will be submitted prior to Contractor commencing work on the project (only if requested) in accordance with the Notice Inviting Bids.
10. FAITHFUL PERFORMANCE & PAYMENT BONDS: It is understood and agreed that if Bidder is providing goods and services in excess of \$25,000.00 and written notice of the acceptance of this bid is mailed or delivered to the undersigned after the opening of the bid, and within the time this bid is required to remain open, or at any time thereafter before this bid is withdrawn, the undersigned will execute and deliver to the AGENCY a fully executed Form of Agreement (Contract) in the form attached hereto in accordance with the bid as accepted, and that it will also furnish and deliver to the AGENCY three (3) executed copies of a Faithful Performance Bond and a separate Payment Bond as specified, and certificates of insurance, all within ten (10) calendar days after receipt of notification of the acceptance . The performance bond and

payment bond must be obtained from sureties listed on the Department of the Treasury's Circular 570 approved list.

Bidder further agrees that the work under the Contract will be commenced by the Bidder, if awarded the Contract, on the date to be stated in the AGENCY's "Notice to Proceed" and will be completed within the time specified in the Contract documents.

11. **PROPER ADDRESS:** Notice of Award of Contract or other correspondence should be addressed to the undersigned at the address stated below.

9650 Business Center Dr. Suite 122 Rancho Cucamonga CA 91730  
 \_\_\_\_\_  
 \_\_\_\_\_

12. **NAME(S) OF PRINCIPALS:** Principals of the Bidder's company are:

Kal Sayegh - Owner  
 \_\_\_\_\_  
 \_\_\_\_\_  
 \_\_\_\_\_  
 \_\_\_\_\_

(IMPORTANT NOTICE: If Bidder is a corporation, state legal name of corporation, as well as names of the president, secretary treasurer, and general manager thereof; if a partnership, state true name of firm, also names of all individual partners composing firm; if an individual, state names in full.)

13. The undersigned bidder declares that the bidder is licensed in the State of California as required by the Business and Professional Code in accordance with the act providing for registration of Contractors and the documentation of licensure is as follows:

<b>License No.</b>	<b>Classification</b>	<b>Expiration Date</b>
<u>1041655</u>	<u>C12</u>	<u>07/31/2026</u>
_____	_____	_____
_____	_____	_____
_____	_____	_____

If the bidder is a joint venture, each member of the joint venture must include the above information Bidder certifies that the above-mentioned license(s) entitle(s) Bidder to provide the work required by the Contract, that such license will be in full force and effect

throughout the duration of work under this Contract, and that any and all subcontractors to be employed for the work will have appropriate licenses.

14. **FORFEITURE OF SECURITY:** In the event the Bidder to whom the Notice of Award of Contract is given fails or refuses to post the required bonds and return executed copies of the Form of Agreement with all required attachments within ten (10) calendar days from the date of the Notice of Award, the AGENCY may declare the Bidder's bid deposit or bond forfeited as liquidated damages.
15. **ASSIGNMENT OF RIGHTS, TITLE AND INTEREST IN CAUSES OF ACTION:** Pursuant to Section 4552 of the Government code, in submitting a bid to the AGENCY, the bidder offers and agrees that if the bid is accepted, it will assign to AGENCY all rights, title, and interest in and to all causes of action it may have under Section 4 of the Clayton Act (15 U.S.C. Section 15) or under the Cartwright Act (Chapter 2 (commencing with Section 16700) of Part 2 of Division 7 of the Business and Professions Code), arising from purchases of goods, materials, or services by the bidder for sale to the purchasing body pursuant to the bid. Such assignment shall be made and become effective at the time the purchasing body tenders final payment to the bidder.
16. **IRCA:** The bidder hereby certifies that it is, and at all times during the performance of work hereunder will be, in full compliance with the provisions of the Immigration Reform and Control Act of 1986 ("IRCA") in the hiring of its employees and the bidder shall indemnify, hold harmless and defend the AGENCY against any and all actions, proceedings, penalties or claims arising out of the bidder's failure to comply strictly with the IRCA.
17. **FINANCIAL STATEMENTS:** It is understood and agreed that if requested by the AGENCY, the Bidder will furnish a notarized financial statement, references and other information required by the AGENCY sufficiently comprehensive to permit an appraisal of bidder's ability to perform the work of the Contract.
18. **LIQUIDATED DAMAGES:** The undersigned hereby warrants that all work shall be completed within **60 consecutive calendar days** from the date specified on the Notice to Proceed issued by the AGENCY. Time is of the essence. The undersigned agrees that failure to complete the work or any scheduled activity within the time set forth herein will result in the imposition of liquidated damages for each consecutive calendar day of delay in the amount of **\$1,000/calendar day**.
19. **CHANGE ORDER REQUESTS:** Bidder understands and agrees that all change order requests must be submitted in the form set forth in the Contract Documents. The amount of allowable charges submitted pursuant to a change order shall be limited to the charges allowed by the Conditions of the Contract. Indirect costs, consequential and incidental

costs, project management costs, extended home office and field office overhead, administrative costs and profit and other charges not specifically authorized by the Contract Conditions will not be allowed.

20. NOTICE REQUIRED BY DEPARTMENT OF INDUSTRIAL RELATIONS: As of January 1, 2015, the call for bids and contract documents for public improvement project must include the following information:

No contractor or subcontractor may be listed on a bid proposal for a public works project (submitted on or after March 1, 2015) unless registered with the Department of Industrial Relations pursuant to Labor Code section 1725.5 [with limited exceptions from this requirement for bid purposes only under Labor Code section 1771.1(a)].

No contractor or subcontractor may be awarded a contract for public work on a public works project (awarded on or after April 1, 2015) unless registered with the Department of Industrial Relations pursuant to Labor Code section 1725.5.

This project is subject to compliance monitoring and enforcement by the Department of Industrial Relations.

**The following documents must be submitted with this Bid Form.**

1. Bidder's Noncollusion Affidavit
2. Contractor Information Sheets
3. Proposed Subcontractors
4. Bidder References and Responsibility Information

The undersigned declares and certifies under penalty of perjury under the laws of the State of California that the foregoing is true and correct.

Geo Paving and Seal Coating

Name of Corporation, Partnership or Sole Proprietor

9650 Business Center Dr. Suite 122 Rancho Cucamonga CA 91730. (951)463-7002

Address & Telephone

Kal Sayegh

Proper Name of Bidder Empowered to Sign on Behalf of the Corporation, Partnership or Sole Proprietor

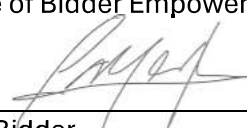
  
Signature of Bidder

SAN BERNARDINO INTERNATIONAL AIRPORT AUTHORITY  
GENERAL AVIATION RAMP (PHASE II) PROJECT

NOTE: If bidder is a corporation, the legal name of the corporation shall be set forth above together with the signature of authorized officers of agents and the document shall bear the corporate seal; if bidder is a partnership, the true name of the firm shall be set forth above together with the signature of the partner or partners authorized to sign contracts on behalf of the partnership; and if bidder is an individual, his or her name and signature shall be placed above.

**BID FORM**

**TO:** San Bernardino International Airport Authority, acting by and through its Governing Board, herein called the "AGENCY."

**FROM:** Roy Allan Slurry Seal, Inc.

(Proper Name of Bidder)

1. Pursuant to and in compliance with your Notice Inviting Bids and the other documents relating thereto, the undersigned Bidder, having familiarized himself/herself with the terms of the Contract and the Contract Documents, the environmental permit requirements, the local conditions affecting the performance of the Contract and the cost of the work at the place where the work is to be done, hereby proposes and agrees to perform within the time stipulated, the Work of the Contract, including all of its component parts, and the furnishing of all materials and equipment required to be incorporated in and form a permanent part of the work; the furnishing of tools, equipment, supplies, transportation, utilities, facilities, labor, superintendence and services required to perform and complete the work; bonds, insurance and submittals; and including the assumption of all obligations, duties and responsibilities necessary to the successful completion of the Contract, including its acceptance by the AGENCY.
2. ADDENDA: The Contractor shall acknowledge via the PlanetBids website the issuance of all Addenda.
3. BID SCHEDULE ITEMS: See next page.

**BID SCHEDULE ITEMS**

SCOPE OF WORK	QTY	UNIT	UNIT COST	FEE
<i>All line items shall be performed in accordance with the Project Plans, Details, and Specifications</i>				
<b>BASE BID: YELLOW AREA</b>				
1. MOBILIZATION / DEMOBILIZATION (5% MAXIMUM OF BASE BID)	1	LS	\$12,500.00	\$12,500.00
2. CONSTRUCTION SAFETY AND PHASING PLAN (CSPP)	1	LS	\$3,500.00	\$3,500.00
3. HEAVY WASH EXISTING ASPHALT TO GET RID OF LOOSE GRAVEL, ROCKS, AND ALL OTHER DEBRIS	1	LS	\$5,064.00	\$5,064.00
4. PATCH & FILL ALL HOLES AND CRACKS GREATER THAN 6" DEEP WITH HOT ASPHALT	1	LS	\$9,851.00	\$9,851.00
5. SOAK PREPPED SURFACE WITH THICK COAT OF FOG SEAL (BEFORE SLURRY SEAL APPLICATION)	73,150	SF	\$.22	\$16,093.00
6. APPLY (1) THICK COAT OF TYPE II ROAD SLURRY SEAL	73,150	SF	\$.56	\$40,964.00
7. APPLY FINAL THICK COAT OF FOG SEAL (OVER SLURRY SEAL APPLICATION)	73,150	SF	\$.22	\$16,093.00
8. GRIND ALL ASPHALT-TO-CONCRETE INTERFACE SURFACES; TO ACHIEVE SMOOTH / FLUSH TRANSITIONS	1	LS	\$5,500.00	\$5,500.00
9. REMOVE EXISTING AIRPLANE TIE DOWN AND FILL HOLE PER PAVEMENT REPAIR DETAILS PLAN	1	EA	\$7,500.00	\$7,500.00
<b>BASE BID SUBTOTAL:</b>			<b>\$117,065.00</b>	
<b>BID ALTERNATE 1: BLUE AREA</b>				
10. **HEAVY WASH EXISTING ASPHALT TO GET RID OF LOOSE GRAVEL, ROCKS, AND ALL OTHER DEBRIS	1	LS	\$1,400.00	\$1,400.00
11. **PATCH & FILL ALL HOLES AND CRACKS GREATER THAN 6" DEEP WITH HOT ASPHALT	1	LS	\$2,780.00	\$2,780.00

SAN BERNARDINO INTERNATIONAL AIRPORT AUTHORITY  
 GENERAL AVIATION RAMP (PHASE II) PROJECT

12. **SOAK PREPPED SURFACE WITH THICK COAT OF FOG SEAL (BEFORE SLURRY SEAL APPLICATION)	16,000	SF	\$ .22	\$3,520.00
13. **APPLY (1) THICK COAT OF TYPE II ROAD SLURRY SEAL	16,000	SF	\$ .56	\$8,960.00
14. **APPLY FINAL THICK COAT OF FOG SEAL (OVER SLURRY SEAL APPLICATION)	16,000	SF	\$ .22	\$3,520.00
15. **GRIND ALL ASPHALT-TO-CONCRETE INTERFACE SURFACES; TO ACHIEVE SMOOTH / FLUSH TRANSITIONS	1	LS	\$1,500.00	\$1,500.00
<b>BID ALTERNATE 1 SUBTOTAL:</b>			<b>\$21,680.00</b>	
<b>GRAND TOTAL:</b>			<b>\$138,745.00</b>	

**NOTE: \*\* Indicates possible Bid Alternate Items.**

**INCLUSIONS:**

**The following items are to be made part of the original scope of work, as well as any applicable bid alternates, and must be included in the Contractor's total bid cost.**

- Contractor to provide a dedicated staging area. It is critical to keep the site clean daily as the establishment operates continuously.
- A full submittal package will be required for scope of work items as directed.

**TOTAL AMOUNT OF BASE BID (NOT INCLUDING ALTERNATE ITEMS)**

**\$117,065.00**

---

\$USD (TOTAL BID AMOUNT IN NUMBERS)

**One Hundred seventeen thousand, sixty five dollars and zero cents.**

---

(TOTAL BID AMOUNT WRITTEN)

**TOTAL AMOUNT OF BID (INCLUDING ALTERNATE ITEMS)**

**\$138,745.00**

---

\$USD (TOTAL BID AMOUNT IN NUMBERS)

**One hundred thirty eight thousand, seven hundred forty five dollars and zero cents.**

---

(TOTAL BID AMOUNT WRITTEN)

The total of all bid item values listed above must equal the total base bid listed above on Bid Form (written in numbers and words). In the case of a discrepancy between mathematical calculations listed in the bid items and the actual total, the amount shown in Bid Amounts shall govern for the basis of determining low bidder.

The undersigned Bidder agrees to achieve Final Completion of the Work and all Major Milestones within the Contract Time set forth in the Contract Documents.

4. **TIME FOR COMPLETION:** The entire Project shall be completed within **60 consecutive calendar days**. Bidder acknowledges liability for liquidated damages in the amount as stipulated herein for each calendar day of delay.
5. **AGENCY'S RIGHT TO REJECT:** It is understood that the AGENCY reserves the right to reject this bid and that the bid shall remain open to acceptance and is irrevocable for a period of **one hundred and twenty (120) days**.
6. **PROPOSED SUBCONTRACTORS:** The required list of proposed subcontractors is attached hereto. Bidder understands and acknowledges that all subcontractors providing goods and services in excess of \$100,000.00 must be bonded in accordance with the Subletting and Subcontracting Fair Practices Act.
7. **NONCOLLUSION AFFIDAVIT:** The required notarized Bidder's Noncollusion Affidavit is attached hereto.
8. **CONTRACTOR INFORMATION SHEETS:** The required Contractor Information Sheets are attached hereto.
9. **CRIMINAL BACKGROUND CHECK CERTIFICATION:** The required Criminal Background Check Certification will be submitted prior to Contractor commencing work on the project (only if requested) in accordance with the Notice Inviting Bids.
10. **FAITHFUL PERFORMANCE & PAYMENT BONDS:** It is understood and agreed that if Bidder is providing goods and services in excess of \$25,000.00 and written notice of the acceptance of this bid is mailed or delivered to the undersigned after the opening of the bid, and within the time this bid is required to remain open, or at any time thereafter before this bid is withdrawn, the undersigned will execute and deliver to the AGENCY a fully executed Form of Agreement (Contract) in the form attached hereto in accordance with the bid as accepted, and that it will also furnish and deliver to the AGENCY three (3) executed copies of a Faithful Performance Bond and a separate Payment Bond as specified, and certificates of insurance, all within ten (10) calendar days after receipt of notification of the acceptance. The performance bond and



- throughout the duration of work under this Contract, and that any and all subcontractors to be employed for the work will have appropriate licenses.
14. **FORFEITURE OF SECURITY:** In the event the Bidder to whom the Notice of Award of Contract is given fails or refuses to post the required bonds and return executed copies of the Form of Agreement with all required attachments within ten (10) calendar days from the date of the Notice of Award, the AGENCY may declare the Bidder's bid deposit or bond forfeited as liquidated damages.
  15. **ASSIGNMENT OF RIGHTS, TITLE AND INTEREST IN CAUSES OF ACTION:** Pursuant to Section 4552 of the Government code, in submitting a bid to the AGENCY, the bidder offers and agrees that if the bid is accepted, it will assign to AGENCY all rights, title, and interest in and to all causes of action it may have under Section 4 of the Clayton Act (15 U.S.C. Section 15) or under the Cartwright Act (Chapter 2 (commencing with Section 16700) of Part 2 of Division 7 of the Business and Professions Code), arising from purchases of goods, materials, or services by the bidder for sale to the purchasing body pursuant to the bid. Such assignment shall be made and become effective at the time the purchasing body tenders final payment to the bidder.
  16. **IRCA:** The bidder hereby certifies that it is, and at all times during the performance of work hereunder will be, in full compliance with the provisions of the Immigration Reform and Control Act of 1986 ("IRCA") in the hiring of its employees and the bidder shall indemnify, hold harmless and defend the AGENCY against any and all actions, proceedings, penalties or claims arising out of the bidder's failure to comply strictly with the IRCA.
  17. **FINANCIAL STATEMENTS:** It is understood and agreed that if requested by the AGENCY, the Bidder will furnish a notarized financial statement, references and other information required by the AGENCY sufficiently comprehensive to permit an appraisal of bidder's ability to perform the work of the Contract.
  18. **LIQUIDATED DAMAGES:** The undersigned hereby warrants that all work shall be completed within **60 consecutive calendar days** from the date specified on the Notice to Proceed issued by the AGENCY. Time is of the essence. The undersigned agrees that failure to complete the work or any scheduled activity within the time set forth herein will result in the imposition of liquidated damages for each consecutive calendar day of delay in the amount of **\$1,000/calendar day**.
  19. **CHANGE ORDER REQUESTS:** Bidder understands and agrees that all change order requests must be submitted in the form set forth in the Contract Documents. The amount of allowable charges submitted pursuant to a change order shall be limited to the charges allowed by the Conditions of the Contract. Indirect costs, consequential and incidental

costs, project management costs, extended home office and field office overhead, administrative costs and profit and other charges not specifically authorized by the Contract Conditions will not be allowed.

20. NOTICE REQUIRED BY DEPARTMENT OF INDUSTRIAL RELATIONS: As of January 1, 2015, the call for bids and contract documents for public improvement project must include the following information:

No contractor or subcontractor may be listed on a bid proposal for a public works project (submitted on or after March 1, 2015) unless registered with the Department of Industrial Relations pursuant to Labor Code section 1725.5 [with limited exceptions from this requirement for bid purposes only under Labor Code section 1771.1(a)].

No contractor or subcontractor may be awarded a contract for public work on a public works project (awarded on or after April 1, 2015) unless registered with the Department of Industrial Relations pursuant to Labor Code section 1725.5.

This project is subject to compliance monitoring and enforcement by the Department of Industrial Relations.

**The following documents must be submitted with this Bid Form.**

1. Bidder's Noncollusion Affidavit
2. Contractor Information Sheets
3. Proposed Subcontractors
4. Bidder References and Responsibility Information

The undersigned declares and certifies under penalty of perjury under the laws of the State of California that the foregoing is true and correct.

**Roy Allan Slurry Seal, Inc.**

Name of Corporation, Partnership or Sole Proprietor

12643 Emmens Way, Santa fe Springs, Ca. 90670 562 864-3363

Address & Telephone

**Lawrence Allan**

Proper Name of Bidder Empowered to Sign on Behalf of the Corporation, Partnership or Sole Proprietor



Signature of Bidder

SAN BERNARDINO INTERNATIONAL AIRPORT AUTHORITY  
GENERAL AVIATION RAMP (PHASE II) PROJECT

**NOTE:** If bidder is a corporation, the legal name of the corporation shall be set forth above together with the signature of authorized officers of agents and the document shall bear the corporate seal; if bidder is a partnership, the true name of the firm shall be set forth above together with the signature of the partner or partners authorized to sign contracts on behalf of the partnership; and if bidder is an individual, his or her name and signature shall be placed above.

**BID FORM**

**TO:** San Bernardino International Airport Authority, acting by and through its Governing Board, herein called the "AGENCY."

**FROM:** Riverside Slurry Seal Inc.  
(Proper Name of Bidder)

1. Pursuant to and in compliance with your Notice Inviting Bids and the other documents relating thereto, the undersigned Bidder, having familiarized himself/herself with the terms of the Contract and the Contract Documents, the environmental permit requirements, the local conditions affecting the performance of the Contract and the cost of the work at the place where the work is to be done, hereby proposes and agrees to perform within the time stipulated, the Work of the Contract, including all of its component parts, and the furnishing of all materials and equipment required to be incorporated in and form a permanent part of the work; the furnishing of tools, equipment, supplies, transportation, utilities, facilities, labor, superintendence and services required to perform and complete the work; bonds, insurance and submittals; and including the assumption of all obligations, duties and responsibilities necessary to the successful completion of the Contract, including its acceptance by the AGENCY.
2. **ADDENDA:** The Contractor shall acknowledge via the PlanetBids website the issuance of all Addenda.
3. **BID SCHEDULE ITEMS:** See next page.

SAN BERNARDINO INTERNATIONAL AIRPORT AUTHORITY  
 GENERAL AVIATION RAMP (PHASE II) PROJECT

**BID SCHEDULE ITEMS**

SCOPE OF WORK	QTY	UNIT	UNIT COST	FEE
<i>All line items shall be performed in accordance with the Project Plans, Details, and Specifications</i>				
<b>BASE BID: YELLOW AREA</b>				
1. MOBILIZATION / DEMOBILIZATION (5% MAXIMUM OF BASE BID)	1	LS	\$ 5,000.00	\$ 5,000.00
2. CONSTRUCTION SAFETY AND PHASING PLAN (CSPP)	1	LS	\$ 10,000.00	\$ 10,000.00
3. HEAVY WASH EXISTING ASPHALT TO GET RID OF LOOSE GRAVEL, ROCKS, AND ALL OTHER DEBRIS	1	LS	\$ 20,000.00	\$ 20,000.00
4. PATCH & FILL ALL HOLES AND CRACKS GREATER THAN 6" DEEP WITH HOT ASPHALT	1	LS	\$ 15,000.00	\$ 15,000.00
5. SOAK PREPPED SURFACE WITH THICK COAT OF FOG SEAL (BEFORE SLURRY SEAL APPLICATION)	73,150	SF	\$ 0.12	\$ 8,778.00
6. APPLY (1) THICK COAT OF TYPE II ROAD SLURRY SEAL	73,150	SF	\$ 0.46	\$ 33,649.00
7. APPLY FINAL THICK COAT OF FOG SEAL (OVER SLURRY SEAL APPLICATION)	73,150	SF	\$ 0.12	\$ 8,778.00
8. GRIND ALL ASPHALT-TO-CONCRETE INTERFACE SURFACES; TO ACHIEVE SMOOTH / FLUSH TRANSITIONS	1	LS	\$ 5,000.00	\$ 5,000.00
9. REMOVE EXISTING AIRPLANE TIE DOWN AND FILL HOLE PER PAVEMENT REPAIR DETAILS PLAN	1	EA	\$ 7,500.00	\$ 7,500.00
<b>BASE BID SUBTOTAL:</b>			\$ 113,705.00	
<b>BID ALTERNATE 1: BLUE AREA</b>				
10. **HEAVY WASH EXISTING ASPHALT TO GET RID OF LOOSE GRAVEL, ROCKS, AND ALL OTHER DEBRIS	1	LS	\$ 5,000.00	\$ 5,000.00
11. **PATCH & FILL ALL HOLES AND CRACKS GREATER THAN 6" DEEP WITH HOT ASPHALT	1	LS	\$ 10,000.00	\$ 10,000.00

SAN BERNARDINO INTERNATIONAL AIRPORT AUTHORITY  
 GENERAL AVIATION RAMP (PHASE II) PROJECT

12. **SOAK PREPPED SURFACE WITH THICK COAT OF FOG SEAL (BEFORE SLURRY SEAL APPLICATION)	16,000	SF	\$ 0.12	\$ 1,920.00
13. **APPLY (1) THICK COAT OF TYPE II ROAD SLURRY SEAL	16,000	SF	\$ 0.46	\$ 7,360.00
14. **APPLY FINAL THICK COAT OF FOG SEAL (OVER SLURRY SEAL APPLICATION)	16,000	SF	\$ 0.12	\$ 1,920.00
15. **GRIND ALL ASPHALT-TO-CONCRETE INTERFACE SURFACES; TO ACHIEVE SMOOTH / FLUSH TRANSITIONS	1	LS	\$ 3,000.00	\$ 3,000.00
<b>BID ALTERNATE 1 SUBTOTAL:</b>			\$ 29,200.00	
<b>GRAND TOTAL:</b>			\$ 142,905.00	

**NOTE: \*\* Indicates possible Bid Alternate Items.**

**INCLUSIONS:**

The following items are to be made part of the original scope of work, as well as any applicable bid alternates, and must be included in the Contractor's total bid cost.

- Contractor to provide a dedicated staging area. It is critical to keep the site clean daily as the establishment operates continuously.
- A full submittal package will be required for scope of work items as directed.

**TOTAL AMOUNT OF BASE BID (NOT INCLUDING ALTERNATE ITEMS)**

\$ 113,705.00

\$USD (TOTAL BID AMOUNT IN NUMBERS)

One Hundred Thirteen Thousand Seven Hundred Five dollars and zero cents  
 (TOTAL BID AMOUNT WRITTEN)

**TOTAL AMOUNT OF BID (INCLUDING ALTERNATE ITEMS)**

\$ 142,905.00

\$USD (TOTAL BID AMOUNT IN NUMBERS)

One Hundred Forty Two Thousand Nine Hundred Five dollars and zero cents  
 (TOTAL BID AMOUNT WRITTEN)

SAN BERNARDINO INTERNATIONAL AIRPORT AUTHORITY  
GENERAL AVIATION RAMP (PHASE II) PROJECT

The total of all bid item values listed above must equal the total base bid listed above on Bid Form (written in numbers and words). In the case of a discrepancy between mathematical calculations listed in the bid items and the actual total, the amount shown in Bid Amounts shall govern for the basis of determining low bidder.

The undersigned Bidder agrees to achieve Final Completion of the Work and all Major Milestones within the Contract Time set forth in the Contract Documents.

4. **TIME FOR COMPLETION**: The entire Project shall be completed within **60 consecutive calendar days**. Bidder acknowledges liability for liquidated damages in the amount as stipulated herein for each calendar day of delay.
5. **AGENCY'S RIGHT TO REJECT**: It is understood that the AGENCY reserves the right to reject this bid and that the bid shall remain open to acceptance and is irrevocable for a period of **one hundred and twenty (120) days**.
6. **PROPOSED SUBCONTRACTORS**: The required list of proposed subcontractors is attached hereto. Bidder understands and acknowledges that all subcontractors providing goods and services in excess of \$100,000.00 must be bonded in accordance with the Subletting and Subcontracting Fair Practices Act.
7. **NONCOLLUSION AFFIDAVIT**: The required notarized Bidder's Noncollusion Affidavit is attached hereto.
8. **CONTRACTOR INFORMATION SHEETS**: The required Contractor Information Sheets are attached hereto.
9. **CRIMINAL BACKGROUND CHECK CERTIFICATION**: The required Criminal Background Check Certification will be submitted prior to Contractor commencing work on the project (only if requested) in accordance with the Notice Inviting Bids.
10. **FAITHFUL PERFORMANCE & PAYMENT BONDS**: It is understood and agreed that if Bidder is providing goods and services in excess of \$25,000.00 and written notice of the acceptance of this bid is mailed or delivered to the undersigned after the opening of the bid, and within the time this bid is required to remain open, or at any time thereafter before this bid is withdrawn, the undersigned will execute and deliver to the AGENCY a fully executed Form of Agreement (Contract) in the form attached hereto in accordance with the bid as accepted, and that it will also furnish and deliver to the AGENCY three (3) executed copies of a Faithful Performance Bond and a separate Payment Bond as specified, and certificates of insurance, all within ten (10) calendar days after receipt of notification of the acceptance . The performance bond and

SAN BERNARDINO INTERNATIONAL AIRPORT AUTHORITY  
 GENERAL AVIATION RAMP (PHASE II) PROJECT

payment bond must be obtained from sureties listed on the Department of the Treasury's Circular 570 approved list.

Bidder further agrees that the work under the Contract will be commenced by the Bidder, if awarded the Contract, on the date to be stated in the AGENCY's "Notice to Proceed" and will be completed within the time specified in the Contract documents.

11. PROPER ADDRESS: Notice of Award of Contract or other correspondence should be addressed to the undersigned at the address stated below.

2395 Mary Street, Riverside, CA 92506

12. NAME(S) OF PRINCIPALS: Principals of the Bidder's company are:

Tyler Skender - President, Treasurer, Secretary

(IMPORTANT NOTICE: If Bidder is a corporation, state legal name of corporation, as well as names of the president, secretary treasurer, and general manager thereof; if a partnership, state true name of firm, also names of all individual partners composing firm; if an individual, state names in full.)

13. The undersigned bidder declares that the bidder is licensed in the State of California as required by the Business and Professional Code in accordance with the act providing for registration of Contractors and the documentation of licensure is as follows:

<u>License No.</u>	<u>Classification</u>	<u>Expiration Date</u>
<u>1115560</u>	<u>A, C-32</u>	<u>1/31/2028</u>
_____	_____	_____
_____	_____	_____
_____	_____	_____

If the bidder is a joint venture, each member of the joint venture must include the above information Bidder certifies that the above-mentioned license(s) entitle(s) Bidder to provide the work required by the Contract, that such license will be in full force and effect

throughout the duration of work under this Contract, and that any and all subcontractors to be employed for the work will have appropriate licenses.

14. **FORFEITURE OF SECURITY:** In the event the Bidder to whom the Notice of Award of Contract is given fails or refuses to post the required bonds and return executed copies of the Form of Agreement with all required attachments within ten (10) calendar days from the date of the Notice of Award, the AGENCY may declare the Bidder's bid deposit or bond forfeited as liquidated damages.
15. **ASSIGNMENT OF RIGHTS, TITLE AND INTEREST IN CAUSES OF ACTION:** Pursuant to Section 4552 of the Government code, in submitting a bid to the AGENCY, the bidder offers and agrees that if the bid is accepted, it will assign to AGENCY all rights, title, and interest in and to all causes of action it may have under Section 4 of the Clayton Act (15 U.S.C. Section 15) or under the Cartwright Act (Chapter 2 (commencing with Section 16700) of Part 2 of Division 7 of the Business and Professions Code), arising from purchases of goods, materials, or services by the bidder for sale to the purchasing body pursuant to the bid. Such assignment shall be made and become effective at the time the purchasing body tenders final payment to the bidder.
16. **IRCA:** The bidder hereby certifies that it is, and at all times during the performance of work hereunder will be, in full compliance with the provisions of the Immigration Reform and Control Act of 1986 ("IRCA") in the hiring of its employees and the bidder shall indemnify, hold harmless and defend the AGENCY against any and all actions, proceedings, penalties or claims arising out of the bidder's failure to comply strictly with the IRCA.
17. **FINANCIAL STATEMENTS:** It is understood and agreed that if requested by the AGENCY, the Bidder will furnish a notarized financial statement, references and other information required by the AGENCY sufficiently comprehensive to permit an appraisal of bidder's ability to perform the work of the Contract.
18. **LIQUIDATED DAMAGES:** The undersigned hereby warrants that all work shall be completed within **60 consecutive calendar days** from the date specified on the Notice to Proceed issued by the AGENCY. Time is of the essence. The undersigned agrees that failure to complete the work or any scheduled activity within the time set forth herein will result in the imposition of liquidated damages for each consecutive calendar day of delay in the amount of **\$1,000/calendar day**.
19. **CHANGE ORDER REQUESTS:** Bidder understands and agrees that all change order requests must be submitted in the form set forth in the Contract Documents. The amount of allowable charges submitted pursuant to a change order shall be limited to the charges allowed by the Conditions of the Contract. Indirect costs, consequential and incidental

SAN BERNARDINO INTERNATIONAL AIRPORT AUTHORITY  
GENERAL AVIATION RAMP (PHASE II) PROJECT

costs, project management costs, extended home office and field office overhead, administrative costs and profit and other charges not specifically authorized by the Contract Conditions will not be allowed.

20. NOTICE REQUIRED BY DEPARTMENT OF INDUSTRIAL RELATIONS: As of January 1, 2015, the call for bids and contract documents for public improvement project must include the following information:

No contractor or subcontractor may be listed on a bid proposal for a public works project (submitted on or after March 1, 2015) unless registered with the Department of Industrial Relations pursuant to Labor Code section 1725.5 [with limited exceptions from this requirement for bid purposes only under Labor Code section 1771.1(a)].

No contractor or subcontractor may be awarded a contract for public work on a public works project (awarded on or after April 1, 2015) unless registered with the Department of Industrial Relations pursuant to Labor Code section 1725.5.

This project is subject to compliance monitoring and enforcement by the Department of Industrial Relations.

**The following documents must be submitted with this Bid Form.**

1. Bidder's Noncollusion Affidavit
2. Contractor Information Sheets
3. Proposed Subcontractors
4. Bidder References and Responsibility Information

The undersigned declares and certifies under penalty of perjury under the laws of the State of California that the foregoing is true and correct.

Riverside Slurry Seal Inc

Name of Corporation, Partnership or Sole Proprietor

2395 Mary Street, Riverside, CA 92506 (909) 228 3740

Address & Telephone

Tyler Skender

Proper Name of Bidder Empowered to Sign on Behalf of the Corporation, Partnership or Sole Proprietor

  
Signature of Bidder

SAN BERNARDINO INTERNATIONAL AIRPORT AUTHORITY  
GENERAL AVIATION RAMP (PHASE II) PROJECT

NOTE: If bidder is a corporation, the legal name of the corporation shall be set forth above together with the signature of authorized officers of agents and the document shall bear the corporate seal; if bidder is a partnership, the true name of the firm shall be set forth above together with the signature of the partner or partners authorized to sign contracts on behalf of the partnership; and if bidder is an individual, his or her name and signature shall be placed above.

**BID FORM**

**TO:** San Bernardino International Airport Authority, acting by and through its Governing Board, herein called the "AGENCY."

**FROM:** Union Pavement Services, Inc.

(Proper Name of Bidder)

1. Pursuant to and in compliance with your Notice Inviting Bids and the other documents relating thereto, the undersigned Bidder, having familiarized himself/herself with the terms of the Contract and the Contract Documents, the environmental permit requirements, the local conditions affecting the performance of the Contract and the cost of the work at the place where the work is to be done, hereby proposes and agrees to perform within the time stipulated, the Work of the Contract, including all of its component parts, and the furnishing of all materials and equipment required to be incorporated in and form a permanent part of the work; the furnishing of tools, equipment, supplies, transportation, utilities, facilities, labor, superintendence and services required to perform and complete the work; bonds, insurance and submittals; and including the assumption of all obligations, duties and responsibilities necessary to the successful completion of the Contract, including its acceptance by the AGENCY.
2. ADDENDA: The Contractor shall acknowledge via the PlanetBids website the issuance of all Addenda.
3. BID SCHEDULE ITEMS: See next page.

**BID SCHEDULE ITEMS**

SCOPE OF WORK	QTY	UNIT	UNIT COST	FEE
<i>All line items shall be performed in accordance with the Project Plans, Details, and Specifications</i>				
<b>BASE BID: YELLOW AREA</b>				
1. MOBILIZATION / DEMOBILIZATION (5% MAXIMUM OF BASE BID)	1	LS	\$4,000.00	\$4,000.00
2. CONSTRUCTION SAFETY AND PHASING PLAN (CSPP)	1	LS	\$3,000.00	\$3,000.00
3. HEAVY WASH EXISTING ASPHALT TO GET RID OF LOOSE GRAVEL, ROCKS, AND ALL OTHER DEBRIS	1	LS	\$25,000.00	\$25,000.00
4. PATCH & FILL ALL HOLES AND CRACKS GREATER THAN 6" DEEP WITH HOT ASPHALT	1	LS	\$7,500.00	\$7,500.00
5. SOAK PREPPED SURFACE WITH THICK COAT OF FOG SEAL (BEFORE SLURRY SEAL APPLICATION)	73,150	SF	\$0.08	\$5,852.00
6. APPLY (1) THICK COAT OF TYPE II ROAD SLURRY SEAL	73,150	SF	\$0.86	\$62,909.00
7. APPLY FINAL THICK COAT OF FOG SEAL (OVER SLURRY SEAL APPLICATION)	73,150	SF	\$0.08	\$5,852.00
8. GRIND ALL ASPHALT-TO-CONCRETE INTERFACE SURFACES; TO ACHIEVE SMOOTH / FLUSH TRANSITIONS	1	LS	\$5,000.00	\$5,000.00
9. REMOVE EXISTING AIRPLANE TIE DOWN AND FILL HOLE PER PAVEMENT REPAIR DETAILS PLAN	1	EA	\$5,000.00	\$5,000.00
<b>BASE BID SUBTOTAL:</b>			<b>\$124,113.00</b>	
<b>BID ALTERNATE 1: BLUE AREA</b>				
10. **HEAVY WASH EXISTING ASPHALT TO GET RID OF LOOSE GRAVEL, ROCKS, AND ALL OTHER DEBRIS	1	LS	\$2,000.00	\$2,000.00
11. **PATCH & FILL ALL HOLES AND CRACKS GREATER THAN 6" DEEP WITH HOT ASPHALT	1	LS	\$1,500.00	\$1,500.00

12. **SOAK PREPPED SURFACE WITH THICK COAT OF FOG SEAL (BEFORE SLURRY SEAL APPLICATION)	16,000	SF	\$0.08	\$1,280.00
13. **APPLY (1) THICK COAT OF TYPE II ROAD SLURRY SEAL	16,000	SF	\$0.86	\$13,760.00
14. **APPLY FINAL THICK COAT OF FOG SEAL (OVER SLURRY SEAL APPLICATION)	16,000	SF	\$0.08	\$1,280.00
15. **GRIND ALL ASPHALT-TO-CONCRETE INTERFACE SURFACES; TO ACHIEVE SMOOTH / FLUSH TRANSITIONS	1	LS	\$1,000.00	\$1,000.00
<b>BID ALTERNATE 1 SUBTOTAL:</b>			<b>\$20,820.00</b>	
<b>GRAND TOTAL:</b>			<b>\$144,933.00</b>	

**NOTE: \*\* Indicates possible Bid Alternate Items.**

**INCLUSIONS:**

**The following items are to be made part of the original scope of work, as well as any applicable bid alternates, and must be included in the Contractor's total bid cost.**

- Contractor to provide a dedicated staging area. It is critical to keep the site clean daily as the establishment operates continuously.
- A full submittal package will be required for scope of work items as directed.

**TOTAL AMOUNT OF BASE BID (NOT INCLUDING ALTERNATE ITEMS)**

\$124,113.00

\_\_\_\_\_  
 \$USD (TOTAL BID AMOUNT IN NUMBERS)

One Hundred Twenty Four Thousand, One Hundred Thirteen Dollars and Zero Cents  
 \_\_\_\_\_  
 (TOTAL BID AMOUNT WRITTEN)

**TOTAL AMOUNT OF BID (INCLUDING ALTERNATE ITEMS)**

\$144,933.00

\_\_\_\_\_  
 \$USD (TOTAL BID AMOUNT IN NUMBERS)

One Hundred Forty Four Thousand, Nine Hundred Thirty Three Dollars and Zero Cents  
 \_\_\_\_\_  
 (TOTAL BID AMOUNT WRITTEN)

SAN BERNARDINO INTERNATIONAL AIRPORT AUTHORITY  
GENERAL AVIATION RAMP (PHASE II) PROJECT

The total of all bid item values listed above must equal the total base bid listed above on Bid Form (written in numbers and words). In the case of a discrepancy between mathematical calculations listed in the bid items and the actual total, the amount shown in Bid Amounts shall govern for the basis of determining low bidder.

The undersigned Bidder agrees to achieve Final Completion of the Work and all Major Milestones within the Contract Time set forth in the Contract Documents.

4. **TIME FOR COMPLETION**: The entire Project shall be completed within **60 consecutive calendar days**. Bidder acknowledges liability for liquidated damages in the amount as stipulated herein for each calendar day of delay.
5. **AGENCY'S RIGHT TO REJECT**: It is understood that the AGENCY reserves the right to reject this bid and that the bid shall remain open to acceptance and is irrevocable for a period of **one hundred and twenty (120) days**.
6. **PROPOSED SUBCONTRACTORS**: The required list of proposed subcontractors is attached hereto. Bidder understands and acknowledges that all subcontractors providing goods and services in excess of \$100,000.00 must be bonded in accordance with the Subletting and Subcontracting Fair Practices Act.
7. **NONCOLLUSION AFFIDAVIT**: The required notarized Bidder's Noncollusion Affidavit is attached hereto.
8. **CONTRACTOR INFORMATION SHEETS**: The required Contractor Information Sheets are attached hereto.
9. **CRIMINAL BACKGROUND CHECK CERTIFICATION**: The required Criminal Background Check Certification will be submitted prior to Contractor commencing work on the project (only if requested) in accordance with the Notice Inviting Bids.
10. **FAITHFUL PERFORMANCE & PAYMENT BONDS**: It is understood and agreed that if Bidder is providing goods and services in excess of \$25,000.00 and written notice of the acceptance of this bid is mailed or delivered to the undersigned after the opening of the bid, and within the time this bid is required to remain open, or at any time thereafter before this bid is withdrawn, the undersigned will execute and deliver to the AGENCY a fully executed Form of Agreement (Contract) in the form attached hereto in accordance with the bid as accepted, and that it will also furnish and deliver to the AGENCY three (3) executed copies of a Faithful Performance Bond and a separate Payment Bond as specified, and certificates of insurance, all within ten (10) calendar days after receipt of notification of the acceptance . The performance bond and



throughout the duration of work under this Contract, and that any and all subcontractors to be employed for the work will have appropriate licenses.

14. **FORFEITURE OF SECURITY:** In the event the Bidder to whom the Notice of Award of Contract is given fails or refuses to post the required bonds and return executed copies of the Form of Agreement with all required attachments within ten (10) calendar days from the date of the Notice of Award, the AGENCY may declare the Bidder's bid deposit or bond forfeited as liquidated damages.
15. **ASSIGNMENT OF RIGHTS, TITLE AND INTEREST IN CAUSES OF ACTION:** Pursuant to Section 4552 of the Government code, in submitting a bid to the AGENCY, the bidder offers and agrees that if the bid is accepted, it will assign to AGENCY all rights, title, and interest in and to all causes of action it may have under Section 4 of the Clayton Act (15 U.S.C. Section 15) or under the Cartwright Act (Chapter 2 (commencing with Section 16700) of Part 2 of Division 7 of the Business and Professions Code), arising from purchases of goods, materials, or services by the bidder for sale to the purchasing body pursuant to the bid. Such assignment shall be made and become effective at the time the purchasing body tenders final payment to the bidder.
16. **IRCA:** The bidder hereby certifies that it is, and at all times during the performance of work hereunder will be, in full compliance with the provisions of the Immigration Reform and Control Act of 1986 ("IRCA") in the hiring of its employees and the bidder shall indemnify, hold harmless and defend the AGENCY against any and all actions, proceedings, penalties or claims arising out of the bidder's failure to comply strictly with the IRCA.
17. **FINANCIAL STATEMENTS:** It is understood and agreed that if requested by the AGENCY, the Bidder will furnish a notarized financial statement, references and other information required by the AGENCY sufficiently comprehensive to permit an appraisal of bidder's ability to perform the work of the Contract.
18. **LIQUIDATED DAMAGES:** The undersigned hereby warrants that all work shall be completed within **60 consecutive calendar days** from the date specified on the Notice to Proceed issued by the AGENCY. Time is of the essence. The undersigned agrees that failure to complete the work or any scheduled activity within the time set forth herein will result in the imposition of liquidated damages for each consecutive calendar day of delay in the amount of **\$1,000/calendar day**.
19. **CHANGE ORDER REQUESTS:** Bidder understands and agrees that all change order requests must be submitted in the form set forth in the Contract Documents. The amount of allowable charges submitted pursuant to a change order shall be limited to the charges allowed by the Conditions of the Contract. Indirect costs, consequential and incidental

SAN BERNARDINO INTERNATIONAL AIRPORT AUTHORITY  
GENERAL AVIATION RAMP (PHASE II) PROJECT

costs, project management costs, extended home office and field office overhead, administrative costs and profit and other charges not specifically authorized by the Contract Conditions will not be allowed.

20. NOTICE REQUIRED BY DEPARTMENT OF INDUSTRIAL RELATIONS: As of January 1, 2015, the call for bids and contract documents for public improvement project must include the following information:

No contractor or subcontractor may be listed on a bid proposal for a public works project (submitted on or after March 1, 2015) unless registered with the Department of Industrial Relations pursuant to Labor Code section 1725.5 [with limited exceptions from this requirement for bid purposes only under Labor Code section 1771.1(a)].

No contractor or subcontractor may be awarded a contract for public work on a public works project (awarded on or after April 1, 2015) unless registered with the Department of Industrial Relations pursuant to Labor Code section 1725.5.

This project is subject to compliance monitoring and enforcement by the Department of Industrial Relations.

**The following documents must be submitted with this Bid Form.**

1. Bidder's Noncollusion Affidavit
2. Contractor Information Sheets
3. Proposed Subcontractors
4. Bidder References and Responsibility Information

The undersigned declares and certifies under penalty of perjury under the laws of the State of California that the foregoing is true and correct.

Union Pavement Services, Inc.

\_\_\_\_\_  
Name of Corporation, Partnership or Sole Proprietor

2904 Rubidoux Blvd., Suite A, Jurupa Valley, CA 92509 (951) 410-4858

\_\_\_\_\_  
Address & Telephone

Doug Ford - Vice President

\_\_\_\_\_  
Proper Name of Bidder Empowered to Sign on Behalf of the Corporation, Partnership or Sole Proprietor

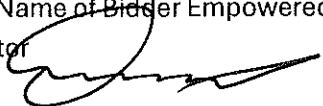
  
\_\_\_\_\_  
Signature of Bidder

SAN BERNARDINO INTERNATIONAL AIRPORT AUTHORITY  
GENERAL AVIATION RAMP (PHASE II) PROJECT

NOTE: If bidder is a corporation, the legal name of the corporation shall be set forth above together with the signature of authorized officers of agents and the document shall bear the corporate seal; if bidder is a partnership, the true name of the firm shall be set forth above together with the signature of the partner or partners authorized to sign contracts on behalf of the partnership; and if bidder is an individual, his or her name and signature shall be placed above.

**BID FORM**

**TO:** San Bernardino International Airport Authority, acting by and through its Governing Board, herein called the "AGENCY."

**FROM:** All American Building Services

\_\_\_\_\_

(Proper Name of Bidder)

1. Pursuant to and in compliance with your Notice Inviting Bids and the other documents relating thereto, the undersigned Bidder, having familiarized himself/herself with the terms of the Contract and the Contract Documents, the environmental permit requirements, the local conditions affecting the performance of the Contract and the cost of the work at the place where the work is to be done, hereby proposes and agrees to perform within the time stipulated, the Work of the Contract, including all of its component parts, and the furnishing of all materials and equipment required to be incorporated in and form a permanent part of the work; the furnishing of tools, equipment, supplies, transportation, utilities, facilities, labor, superintendence and services required to perform and complete the work; bonds, insurance and submittals; and including the assumption of all obligations, duties and responsibilities necessary to the successful completion of the Contract, including its acceptance by the AGENCY.
2. ADDENDA: The Contractor shall acknowledge via the PlanetBids website the issuance of all Addenda.
3. BID SCHEDULE ITEMS: See next page.

**BID SCHEDULE ITEMS**

SCOPE OF WORK	QTY	UNIT	UNIT COST	FEE
<i>All line items shall be performed in accordance with the Project Plans, Details, and Specifications</i>				
<b>BASE BID: YELLOW AREA</b>				
1. MOBILIZATION / DEMOBILIZATION (5% MAXIMUM OF BASE BID)	1	LS	6500	6500
2. CONSTRUCTION SAFETY AND PHASING PLAN (CSPP)	1	LS	4300	4300
3. HEAVY WASH EXISTING ASPHALT TO GET RID OF LOOSE GRAVEL, ROCKS, AND ALL OTHER DEBRIS	1	LS	6500	6500
4. PATCH & FILL ALL HOLES AND CRACKS GREATER THAN 6" DEEP WITH HOT ASPHALT	1	LS	23,000	23,000
5. SOAK PREPPED SURFACE WITH THICK COAT OF FOG SEAL (BEFORE SLURRY SEAL APPLICATION)	73,150	SF	0.25	18,287.50
6. APPLY (1) THICK COAT OF TYPE II ROAD SLURRY SEAL	73,150	SF	0.95	69,492.50
7. APPLY FINAL THICK COAT OF FOG SEAL (OVER SLURRY SEAL APPLICATION)	73,150	SF	0.18	13,167
8. GRIND ALL ASPHALT-TO-CONCRETE INTERFACE SURFACES; TO ACHIEVE SMOOTH / FLUSH TRANSITIONS	1	LS	22,000	22,000
9. REMOVE EXISTING AIRPLANE TIE DOWN AND FILL HOLE PER PAVEMENT REPAIR DETAILS PLAN	1	EA	2500	2500
<b>BASE BID SUBTOTAL:</b>			165,747	
<b>BID ALTERNATE 1: BLUE AREA</b>				
10. **HEAVY WASH EXISTING ASPHALT TO GET RID OF LOOSE GRAVEL, ROCKS, AND ALL OTHER DEBRIS	1	LS	8,500	8500
11. **PATCH & FILL ALL HOLES AND CRACKS GREATER THAN 6" DEEP WITH HOT ASPHALT	1	LS	16,000	16,000

12. **SOAK PREPPED SURFACE WITH THICK COAT OF FOG SEAL (BEFORE SLURRY SEAL APPLICATION)	16,000	SF	0.25	4,000
13. **APPLY (1) THICK COAT OF TYPE II ROAD SLURRY SEAL	16,000	SF	1.50	24,000
14. **APPLY FINAL THICK COAT OF FOG SEAL (OVER SLURRY SEAL APPLICATION)	16,000	SF	0.18	2880
15. **GRIND ALL ASPHALT-TO-CONCRETE INTERFACE SURFACES; TO ACHIEVE SMOOTH / FLUSH TRANSITIONS	1	LS	11,000	11,000
<b>BID ALTERNATE 1 SUBTOTAL:</b>			66,380	
<b>GRAND TOTAL:</b>			232,127	

**NOTE: \*\* Indicates possible Bid Alternate Items.**

**INCLUSIONS:**

**The following items are to be made part of the original scope of work, as well as any applicable bid alternates, and must be included in the Contractor's total bid cost.**

- Contractor to provide a dedicated staging area. It is critical to keep the site clean daily as the establishment operates continuously.
- A full submittal package will be required for scope of work items as directed.

**TOTAL AMOUNT OF BASE BID (NOT INCLUDING ALTERNATE ITEMS)**

165,747

---

\$USD (TOTAL BID AMOUNT IN NUMBERS)

One Hundred Sixty Five Thousand Seven Hundred forty Seven

---

(TOTAL BID AMOUNT WRITTEN)

**TOTAL AMOUNT OF BID (INCLUDING ALTERNATE ITEMS)**

232,127

---

\$USD (TOTAL BID AMOUNT IN NUMBERS)

Two Hundred Thirty Two Thousand One Hundred Twenty Seven

---

(TOTAL BID AMOUNT WRITTEN)

The total of all bid item values listed above must equal the total base bid listed above on Bid Form (written in numbers and words). In the case of a discrepancy between mathematical calculations listed in the bid items and the actual total, the amount shown in Bid Amounts shall govern for the basis of determining low bidder.

The undersigned Bidder agrees to achieve Final Completion of the Work and all Major Milestones within the Contract Time set forth in the Contract Documents.

4. TIME FOR COMPLETION: The entire Project shall be completed within **60 consecutive calendar days**. Bidder acknowledges liability for liquidated damages in the amount as stipulated herein for each calendar day of delay.
5. AGENCY'S RIGHT TO REJECT: It is understood that the AGENCY reserves the right to reject this bid and that the bid shall remain open to acceptance and is irrevocable for a period of **one hundred and twenty (120) days**.
6. PROPOSED SUBCONTRACTORS: The required list of proposed subcontractors is attached hereto. Bidder understands and acknowledges that all subcontractors providing goods and services in excess of \$100,000.00 must be bonded in accordance with the Subletting and Subcontracting Fair Practices Act.
7. NONCOLLUSION AFFIDAVIT: The required notarized Bidder's Noncollusion Affidavit is attached hereto.
8. CONTRACTOR INFORMATION SHEETS: The required Contractor Information Sheets are attached hereto.
9. CRIMINAL BACKGROUND CHECK CERTIFICATION: The required Criminal Background Check Certification will be submitted prior to Contractor commencing work on the project (only if requested) in accordance with the Notice Inviting Bids.
10. FAITHFUL PERFORMANCE & PAYMENT BONDS: It is understood and agreed that if Bidder is providing goods and services in excess of \$25,000.00 and written notice of the acceptance of this bid is mailed or delivered to the undersigned after the opening of the bid, and within the time this bid is required to remain open, or at any time thereafter before this bid is withdrawn, the undersigned will execute and deliver to the AGENCY a fully executed Form of Agreement (Contract) in the form attached hereto in accordance with the bid as accepted, and that it will also furnish and deliver to the AGENCY three (3) executed copies of a Faithful Performance Bond and a separate Payment Bond as specified, and certificates of insurance, all within ten (10) calendar days after receipt of notification of the acceptance . The performance bond and



throughout the duration of work under this Contract, and that any and all subcontractors to be employed for the work will have appropriate licenses.

14. **FORFEITURE OF SECURITY:** In the event the Bidder to whom the Notice of Award of Contract is given fails or refuses to post the required bonds and return executed copies of the Form of Agreement with all required attachments within ten (10) calendar days from the date of the Notice of Award, the AGENCY may declare the Bidder's bid deposit or bond forfeited as liquidated damages. 25,600
15. **ASSIGNMENT OF RIGHTS, TITLE AND INTEREST IN CAUSES OF ACTION:** Pursuant to Section 4552 of the Government code, in submitting a bid to the AGENCY, the bidder offers and agrees that if the bid is accepted, it will assign to AGENCY all rights, title, and interest in and to all causes of action it may have under Section 4 of the Clayton Act (15 U.S.C. Section 15) or under the Cartwright Act (Chapter 2 (commencing with Section 16700) of Part 2 of Division 7 of the Business and Professions Code), arising from purchases of goods, materials, or services by the bidder for sale to the purchasing body pursuant to the bid. Such assignment shall be made and become effective at the time the purchasing body tenders final payment to the bidder.
16. **IRCA:** The bidder hereby certifies that it is, and at all times during the performance of work hereunder will be, in full compliance with the provisions of the Immigration Reform and Control Act of 1986 ("IRCA") in the hiring of its employees and the bidder shall indemnify, hold harmless and defend the AGENCY against any and all actions, proceedings, penalties or claims arising out of the bidder's failure to comply strictly with the IRCA.
17. **FINANCIAL STATEMENTS:** It is understood and agreed that if requested by the AGENCY, the Bidder will furnish a notarized financial statement, references and other information required by the AGENCY sufficiently comprehensive to permit an appraisal of bidder's ability to perform the work of the Contract.
18. **LIQUIDATED DAMAGES:** The undersigned hereby warrants that all work shall be completed within **60 consecutive calendar days** from the date specified on the Notice to Proceed issued by the AGENCY. Time is of the essence. The undersigned agrees that failure to complete the work or any scheduled activity within the time set forth herein will result in the imposition of liquidated damages for each consecutive calendar day of delay in the amount of **\$1,000/calendar day**.
19. **CHANGE ORDER REQUESTS:** Bidder understands and agrees that all change order requests must be submitted in the form set forth in the Contract Documents. The amount of allowable charges submitted pursuant to a change order shall be limited to the charges allowed by the Conditions of the Contract. Indirect costs, consequential and incidental

costs, project management costs, extended home office and field office overhead, administrative costs and profit and other charges not specifically authorized by the Contract Conditions will not be allowed.

20. NOTICE REQUIRED BY DEPARTMENT OF INDUSTRIAL RELATIONS: As of January 1, 2015, the call for bids and contract documents for public improvement project must include the following information:

No contractor or subcontractor may be listed on a bid proposal for a public works project (submitted on or after March 1, 2015) unless registered with the Department of Industrial Relations pursuant to Labor Code section 1725.5 [with limited exceptions from this requirement for bid purposes only under Labor Code section 1771.1(a)].

No contractor or subcontractor may be awarded a contract for public work on a public works project (awarded on or after April 1, 2015) unless registered with the Department of Industrial Relations pursuant to Labor Code section 1725.5.

This project is subject to compliance monitoring and enforcement by the Department of Industrial Relations.

**The following documents must be submitted with this Bid Form.**

1. Bidder's Noncollusion Affidavit
2. Contractor Information Sheets
3. Proposed Subcontractors
4. Bidder References and Responsibility Information

The undersigned declares and certifies under penalty of perjury under the laws of the State of California that the foregoing is true and correct.

All American Building Services

---

Name of Corporation, Partnership or Sole Proprietor

PO BOX 802586 SANTA CLARITA, CA 91380

---

Address & Telephone

Anthony Innabi

---

Proper Name of Bidder Empowered to Sign on Behalf of the Corporation, Partnership or Sole Proprietor

*Anthony Innabi*

---

Signature of Bidder

SAN BERNARDINO INTERNATIONAL AIRPORT AUTHORITY  
GENERAL AVIATION RAMP (PHASE II) PROJECT

NOTE: If bidder is a corporation, the legal name of the corporation shall be set forth above together with the signature of authorized officers of agents and the document shall bear the corporate seal; if bidder is a partnership, the true name of the firm shall be set forth above together with the signature of the partner or partners authorized to sign contracts on behalf of the partnership; and if bidder is an individual, his or her name and signature shall be placed above.

## BID FORM

**TO:** San Bernardino International Airport Authority, acting by and through its Governing Board, herein called the "AGENCY."

**FROM:** Estate Design and Construction

(Proper Name of Bidder)

1. Pursuant to and in compliance with your Notice Inviting Bids and the other documents relating thereto, the undersigned Bidder, having familiarized himself/herself with the terms of the Contract and the Contract Documents, the environmental permit requirements, the local conditions affecting the performance of the Contract and the cost of the work at the place where the work is to be done, hereby proposes and agrees to perform within the time stipulated, the Work of the Contract, including all of its component parts, and the furnishing of all materials and equipment required to be incorporated in and form a permanent part of the work; the furnishing of tools, equipment, supplies, transportation, utilities, facilities, labor, superintendence and services required to perform and complete the work; bonds, insurance and submittals; and including the assumption of all obligations, duties and responsibilities necessary to the successful completion of the Contract, including its acceptance by the AGENCY.
2. ADDENDA: The Contractor shall acknowledge via the PlanetBids website the issuance of all Addenda.
3. BID SCHEDULE ITEMS: See next page.

**BID SCHEDULE ITEMS**

SCOPE OF WORK	QTY	UNIT	UNIT COST	FEE
<i>All line items shall be performed in accordance with the Project Plans, Details, and Specifications</i>				
<b>BASE BID: YELLOW AREA</b>				
1. MOBILIZATION / DEMOBILIZATION (5% MAXIMUM OF BASE BID)	1	LS	\$ 22,200.00	\$ 22,200.00
2. CONSTRUCTION SAFETY AND PHASING PLAN (CSPP)	1	LS	\$ 24,000.00	\$ 24,000.00
3. HEAVY WASH EXISTING ASPHALT TO GET RID OF LOOSE GRAVEL, ROCKS, AND ALL OTHER DEBRIS	1	LS	\$ 18,450.00	\$ 18,450.00
4. PATCH & FILL ALL HOLES AND CRACKS GREATER THAN 6" DEEP WITH HOT ASPHALT	1	LS	\$ 48,000.00	\$ 48,000.00
5. SOAK PREPPED SURFACE WITH THICK COAT OF FOG SEAL (BEFORE SLURRY SEAL APPLICATION)	73,150	SF	\$ 0.46	\$ 33,356.40
6. APPLY (1) THICK COAT OF TYPE II ROAD SLURRY SEAL	73,150	SF	\$ 2.16	\$ 158,004.00
7. APPLY FINAL THICK COAT OF FOG SEAL (OVER SLURRY SEAL APPLICATION)	73,150	SF	\$ 0.38	\$ 28,089.60
8. GRIND ALL ASPHALT-TO-CONCRETE INTERFACE SURFACES; TO ACHIEVE SMOOTH / FLUSH TRANSITIONS	1	LS	\$ 24,000.00	\$ 24,000.00
9. REMOVE EXISTING AIRPLANE TIE DOWN AND FILL HOLE PER PAVEMENT REPAIR DETAILS PLAN	1	EA	\$ 7,800.00	\$ 7,800.00
<b>BASE BID SUBTOTAL:</b>			<b>\$ 363,900.00</b>	
<b>BID ALTERNATE 1: BLUE AREA</b>				
10. **HEAVY WASH EXISTING ASPHALT TO GET RID OF LOOSE GRAVEL, ROCKS, AND ALL OTHER DEBRIS	1	LS	\$ 9,000.00	\$ 9,000.00
11. **PATCH & FILL ALL HOLES AND CRACKS GREATER THAN 6" DEEP WITH HOT ASPHALT	1	LS	\$ 18,000.00	\$ 18,000.00

12. **SOAK PREPPED SURFACE WITH THICK COAT OF FOG SEAL (BEFORE SLURRY SEAL APPLICATION)	16,000	SF	\$ 0.46	\$ 7,296.00
13. **APPLY (1) THICK COAT OF TYPE II ROAD SLURRY SEAL	16,000	SF	\$ 2.16	\$ 34,560.00
14. **APPLY FINAL THICK COAT OF FOG SEAL (OVER SLURRY SEAL APPLICATION)	16,000	SF	\$ 0.38	\$ 6,144.00
15. **GRIND ALL ASPHALT-TO-CONCRETE INTERFACE SURFACES; TO ACHIEVE SMOOTH / FLUSH TRANSITIONS	1	LS	\$ 9,600.00	\$ 9,600.00
<b>BID ALTERNATE 1 SUBTOTAL:</b>			<b>\$ 84,600.00</b>	
<b>GRAND TOTAL:</b>			<b>\$ 448,500.00</b>	

**NOTE: \*\* Indicates possible Bid Alternate Items.**

**INCLUSIONS:**

**The following items are to be made part of the original scope of work, as well as any applicable bid alternates, and must be included in the Contractor's total bid cost.**

- Contractor to provide a dedicated staging area. It is critical to keep the site clean daily as the establishment operates continuously.
- A full submittal package will be required for scope of work items as directed.

**TOTAL AMOUNT OF BASE BID (NOT INCLUDING ALTERNATE ITEMS)**

**\$ 363,900.00**

\$USD (TOTAL BID AMOUNT IN NUMBERS)

**Three Hundred Sixty-Three Thousand Nine Hundred Dollars**

(TOTAL BID AMOUNT WRITTEN)

**TOTAL AMOUNT OF BID (INCLUDING ALTERNATE ITEMS)**

**\$ 448,500.00**

\$USD (TOTAL BID AMOUNT IN NUMBERS)

**Four Hundred Forty-Eight Thousand Five Hundred Dollars**

(TOTAL BID AMOUNT WRITTEN)

The total of all bid item values listed above must equal the total base bid listed above on Bid Form (written in numbers and words). In the case of a discrepancy between mathematical calculations listed in the bid items and the actual total, the amount shown in Bid Amounts shall govern for the basis of determining low bidder.

The undersigned Bidder agrees to achieve Final Completion of the Work and all Major Milestones within the Contract Time set forth in the Contract Documents.

4. **TIME FOR COMPLETION**: The entire Project shall be completed within **60 consecutive calendar days**. Bidder acknowledges liability for liquidated damages in the amount as stipulated herein for each calendar day of delay.
5. **AGENCY'S RIGHT TO REJECT**: It is understood that the AGENCY reserves the right to reject this bid and that the bid shall remain open to acceptance and is irrevocable for a period of **one hundred and twenty (120) days**.
6. **PROPOSED SUBCONTRACTORS**: The required list of proposed subcontractors is attached hereto. Bidder understands and acknowledges that all subcontractors providing goods and services in excess of \$100,000.00 must be bonded in accordance with the Subletting and Subcontracting Fair Practices Act.
7. **NONCOLLUSION AFFIDAVIT**: The required notarized Bidder's Noncollusion Affidavit is attached hereto.
8. **CONTRACTOR INFORMATION SHEETS**: The required Contractor Information Sheets are attached hereto.
9. **CRIMINAL BACKGROUND CHECK CERTIFICATION**: The required Criminal Background Check Certification will be submitted prior to Contractor commencing work on the project (only if requested) in accordance with the Notice Inviting Bids.
10. **FAITHFUL PERFORMANCE & PAYMENT BONDS**: It is understood and agreed that if Bidder is providing goods and services in excess of \$25,000.00 and written notice of the acceptance of this bid is mailed or delivered to the undersigned after the opening of the bid, and within the time this bid is required to remain open, or at any time thereafter before this bid is withdrawn, the undersigned will execute and deliver to the AGENCY a fully executed Form of Agreement (Contract) in the form attached hereto in accordance with the bid as accepted, and that it will also furnish and deliver to the AGENCY three (3) executed copies of a Faithful Performance Bond and a separate Payment Bond as specified, and certificates of insurance, all within ten (10) calendar days after receipt of notification of the acceptance . The performance bond and

payment bond must be obtained from sureties listed on the Department of the Treasury's Circular 570 approved list.

Bidder further agrees that the work under the Contract will be commenced by the Bidder, if awarded the Contract, on the date to be stated in the AGENCY's "Notice to Proceed" and will be completed within the time specified in the Contract documents.

11. **PROPER ADDRESS:** Notice of Award of Contract or other correspondence should be addressed to the undersigned at the address stated below.

Benjamin S. Tvizer

5701 Buckingham Pkwy, UNIT C, Culver City, CA 90230

12. **NAME(S) OF PRINCIPALS:** Principals of the Bidder's company are:

Estate Design and Construction

President: Benjamin S. Tvizer

(IMPORTANT NOTICE: If Bidder is a corporation, state legal name of corporation, as well as names of the president, secretary treasurer, and general manager thereof; if a partnership, state true name of firm, also names of all individual partners composing firm; if an individual, state names in full.)

13. The undersigned bidder declares that the bidder is licensed in the State of California as required by the Business and Professional Code in accordance with the act providing for registration of Contractors and the documentation of licensure is as follows:

<b>License No.</b>	<b>Classification</b>	<b>Expiration Date</b>
<u>1075658</u>	<u>A</u>	<u>06/30/2026</u>
<u>1075658</u>	<u>B</u>	<u>06/30/2026</u>
<u>1075658</u>	<u>C-36</u>	<u>06/30/2026</u>
<u>1075658</u>	<u>C-39</u>	<u>06/30/2026</u>

If the bidder is a joint venture, each member of the joint venture must include the above information Bidder certifies that the above-mentioned license(s) entitle(s) Bidder to provide the work required by the Contract, that such license will be in full force and effect

throughout the duration of work under this Contract, and that any and all subcontractors to be employed for the work will have appropriate licenses.

14. **FORFEITURE OF SECURITY:** In the event the Bidder to whom the Notice of Award of Contract is given fails or refuses to post the required bonds and return executed copies of the Form of Agreement with all required attachments within ten (10) calendar days from the date of the Notice of Award, the AGENCY may declare the Bidder's bid deposit or bond forfeited as liquidated damages.
15. **ASSIGNMENT OF RIGHTS, TITLE AND INTEREST IN CAUSES OF ACTION:** Pursuant to Section 4552 of the Government code, in submitting a bid to the AGENCY, the bidder offers and agrees that if the bid is accepted, it will assign to AGENCY all rights, title, and interest in and to all causes of action it may have under Section 4 of the Clayton Act (15 U.S.C. Section 15) or under the Cartwright Act (Chapter 2 (commencing with Section 16700) of Part 2 of Division 7 of the Business and Professions Code), arising from purchases of goods, materials, or services by the bidder for sale to the purchasing body pursuant to the bid. Such assignment shall be made and become effective at the time the purchasing body tenders final payment to the bidder.
16. **IRCA:** The bidder hereby certifies that it is, and at all times during the performance of work hereunder will be, in full compliance with the provisions of the Immigration Reform and Control Act of 1986 ("IRCA") in the hiring of its employees and the bidder shall indemnify, hold harmless and defend the AGENCY against any and all actions, proceedings, penalties or claims arising out of the bidder's failure to comply strictly with the IRCA.
17. **FINANCIAL STATEMENTS:** It is understood and agreed that if requested by the AGENCY, the Bidder will furnish a notarized financial statement, references and other information required by the AGENCY sufficiently comprehensive to permit an appraisal of bidder's ability to perform the work of the Contract.
18. **LIQUIDATED DAMAGES:** The undersigned hereby warrants that all work shall be completed within **60 consecutive calendar days** from the date specified on the Notice to Proceed issued by the AGENCY. Time is of the essence. The undersigned agrees that failure to complete the work or any scheduled activity within the time set forth herein will result in the imposition of liquidated damages for each consecutive calendar day of delay in the amount of **\$1,000/calendar day**.
19. **CHANGE ORDER REQUESTS:** Bidder understands and agrees that all change order requests must be submitted in the form set forth in the Contract Documents. The amount of allowable charges submitted pursuant to a change order shall be limited to the charges allowed by the Conditions of the Contract. Indirect costs, consequential and incidental

costs, project management costs, extended home office and field office overhead, administrative costs and profit and other charges not specifically authorized by the Contract Conditions will not be allowed.

20. NOTICE REQUIRED BY DEPARTMENT OF INDUSTRIAL RELATIONS: As of January 1, 2015, the call for bids and contract documents for public improvement project must include the following information:

No contractor or subcontractor may be listed on a bid proposal for a public works project (submitted on or after March 1, 2015) unless registered with the Department of Industrial Relations pursuant to Labor Code section 1725.5 [with limited exceptions from this requirement for bid purposes only under Labor Code section 1771.1(a)].

No contractor or subcontractor may be awarded a contract for public work on a public works project (awarded on or after April 1, 2015) unless registered with the Department of Industrial Relations pursuant to Labor Code section 1725.5.

This project is subject to compliance monitoring and enforcement by the Department of Industrial Relations.

**The following documents must be submitted with this Bid Form.**

1. Bidder's Noncollusion Affidavit
2. Contractor Information Sheets
3. Proposed Subcontractors
4. Bidder References and Responsibility Information

The undersigned declares and certifies under penalty of perjury under the laws of the State of California that the foregoing is true and correct.

Estate Design and Construction

Name of Corporation, Partnership or Sole Proprietor

5701 Buckingham Pkwy, UNIT C, Culver City, CA 90230 / 310-810-7319

Address & Telephone

Benjamin S. Tvizer

Proper Name of Bidder Empowered to Sign on Behalf of the Corporation, Partnership or Sole Proprietor

  
Signature of Bidder



SAN BERNARDINO INTERNATIONAL AIRPORT AUTHORITY  
GENERAL AVIATION RAMP (PHASE II) PROJECT

NOTE: If bidder is a corporation, the legal name of the corporation shall be set forth above together with the signature of authorized officers of agents and the document shall bear the corporate seal; if bidder is a partnership, the true name of the firm shall be set forth above together with the signature of the partner or partners authorized to sign contracts on behalf of the partnership; and if bidder is an individual, his or her name and signature shall be placed above.

	<p><b>TO: San Bernardino International Airport Authority Commission</b></p> <p><b>DATE: April 22, 2026</b></p> <p><b>ITEM NO: 12</b></p> <p><b>PRESENTER: Jeff Barrow, Director of Development</b></p>
---	--

**SUBJECT: APPROVE CHANGE ORDER NO. 1 WITH LEONIDA BUILDERS, INC. FOR \$19,550 FOR A TOTAL CONTRACT AMOUNT OF \$507,550 FOR ADDITIONAL WORK RELATED TO THE RE-BID AIRFIELD CANOPIES & UNDERGROUND SERVICE PIT PROJECT**

**SUMMARY**

This Change Order directs the contractor to perform additional work items for the Re-Bid Airfield Canopies & Underground Service Pit Project.

**RECOMMENDED ACTION(S)**

Approve Change Order No. 1 with Leonida Builders, Inc. for an amount not to exceed \$19,550 for a total contract amount of \$507,550 for additional work related to Re-Bid Airfield Canopies & Underground Service Pit Project.

**FISCAL IMPACT**

None. In the event that the proposed budget adjustment is approved on today’s agenda, funding for this project will be included in the then adjusted San Bernardino International Airport Authority (SBIAA) Fiscal Year 2025-2026 Budget, in Budget Class 63 as a Capital Improvement Project, Project Number 25s050-01 – Airfield Canopy and Service Pit for \$520,000 of which \$19,550 and \$507,550 are allocated to Change Order No. 1 and total contract, respectively.

PREPARED BY:	Griselda Lizarraga
CERTIFIED AS TO AVAILABILITY OF FUNDS:	Mark Cousineau
APPROVED AS TO FORM AND LEGAL CONTENT:	Scott Huber
FINAL APPROVAL:	Michael Burrows

## **BACKGROUND INFORMATION**

On January 28, 2026, the San Bernardino International Airport Authority (SBIAA) approved a construction contract with Leonida Builders, Inc. for the Re-Bid Airfield Canopies & Underground Service Pit Project.

During construction activities, it was determined additional work items were required for the successful completion of the project. Additional scope of work includes demolition and removal of existing concrete bollards and sidewalk segment, followed by concrete restoration. Work also includes installation of a waterproofing system at the service pit, placement of new low-voltage conduit, and construction of a new catch basin.

Leonida Builders, Inc. contract and proposed Change Order No. 1:

Original Contract	\$488,000.00
<u>Change Order No. 1</u>	<u>\$19,550.00</u>
New Contract Amount	\$507,550.00

Staff recommends the Board approve the above recommended actions.

### **Attachments:**

1. Change Order No. 1



**San Bernardino International Airport Authority**

1601 E 3<sup>rd</sup> Street

San Bernardino, CA 92408

Phone: (909) 382-4100 Fax: (909) 382-4106

**Change Order 1 to Contract:** Re-Bid Airfield Canopies & Underground Service Pit Project, dated January 29, 2026, by and between: San Bernardino International Airport Authority (Agency), and Leonida Builders, Inc. (Contractor), the Contractor is hereby directed to make the following change in contract work:

ITEM	DESCRIPTION OF CHANGES	TYPE	AMOUNT
01	Remove Bollards and Fix Concrete (4' x 4' Area)	Add	\$2,200.00
02	Remove Sidewalk (20' x 10' Area) and Dispose Material	Add	\$9,800.00
03	Remove Bollards and Repair Concrete	Add	\$1,400.00
04	Waterproof Service Pit Walls (Material & Labor)	Add	\$3,250.00
05	New Catch Basin	Add	\$2,900.00
<b>Total Cost for Change Order 1:</b>		<b>Add</b>	<b>\$19,550.00</b>

**Original Contract Amount: \$488,000.00**

**Executed Change Order 1: \$19,550.00**

**New Contract Amount: \$507,550.00**

**ACCEPTANCE:**

Contractor accepts the terms and conditions stated above as full and final settlement of any and all claims arising from this Change Order and acknowledges that the compensation (time and cost) set forth in the Change Order comprises the total compensation due for the work or change defined in the Change Order, including all impact on any unchanged work. By signing the Change Order, the Contractor acknowledges and agrees that the stipulated compensation includes payment for all Work contained in the Change Order, plus all payment for the interruption of schedules, extended overhead costs, delay, and all impact, ripple effect or cumulative impact on all other Work under this Contract. The signing of the Change Order acknowledges full mutual accord and satisfaction for the change, and that the time and/or cost under the Change Order constitute the total equitable adjustment owed the Contractor as a result of the change. The Contractor agrees to waive all rights, without exception or reservation of any kind whatsoever, to file any further claim or request for equitable adjustment of any type, for any reasonably foreseeable cause that shall arise out of or as a result of this Change Order or the impact of this Change Order on the remainder of the Work under this contract. Contractor agrees to perform the above described work in accordance with the above terms and in compliance with applicable Sections of the Contract Documents. This Change Order is hereby agreed to, accepted and approved, all in accordance with the General Conditions of the Contract Documents.

Accepted by Contractor: \_\_\_\_\_

Date: 4/15/2026

Approved by Agency: \_\_\_\_\_

Date: \_\_\_\_\_

# LEONIDA BUILDERS INC.

32023 Crown Valley Road  
 Acton, CA 93510  
 Licensed and Insured

TEL: (951)532-7717

FAX: (951)566-4022

# PROPOSED CHANGE ORDER

DIR NO: 1001081351  
 LICENSE NO. 896772  
 Classifications: A, B, & C-8

PROJECT NAME: **Re-Bid Airfield Canopies & Underground Service Pit Project**  
 OWNER: **San Bernardino Int'l Airport Authority**

CHANGE ORDER NO: **26009-1.1**  
 DATE: **2/25/2026**

Item No.	Task	Description	Labor				Material					Equipment					
			QTY	Unit	Unit Price	Total	Description	QTY	Units	Unit Price	Total	Equipment	QTY	Unit	Rate	Total	
1	Remove Bollards	Remove Bollards and fix concrete (4'x4' Area)	1	LS	\$2,200.00	\$ 2,200.00											\$ -
2	Remove Sidewalk	Remove Sidewalk Only (20'x10' Area) and Dispose material	1	LS	\$9,800.00	\$ 9,800.00											\$ -
3		Remove Bollards and Repair Concrete	1	LS	\$1,400.00	\$ 1,400.00											\$ -
4		Waterproof Service Pit Walls (Material & Labor)	1	LS	\$3,250.00	\$ 3,250.00											\$ -
5		New Catch Basin	1	LS	\$2,900.00	\$ 2,900.00											\$ -
6						\$ -											\$ -
7						\$ -											\$ -
8						\$ -											\$ -
9						\$ -											\$ -
10						\$ -											\$ -
11						\$ -											\$ -
12						\$ -											\$ -
13						\$ -											\$ -
14						\$ -											\$ -
15						\$ -											\$ -
ADDITIONAL WORKING DAYS: <b>3 Working Days</b>			Labor Total				\$ 19,550.00	Material Total				\$ -	Equipment Total				\$ -
			Labor 15% Mark-up					Material 15% Markup					Equipment 15% Markup				
			Labor Subtotal				\$ 19,550.00	Material Subtotal				\$ -	Equipment Subtotal				\$ -
Notes: Change order for additional Bollard and Sidewalk Removal. Per our observation there seems to be a second pour, please note this proposal is only based on if the concrete is a cold joint. We are not responsible for the concrete below sidewalk. Sidewalk removal is only for 6" depth. If additional depth is required a seperate change order to follow.												Labor Subtotal		\$	19,550.00		
Exclusions:												Material Subtotal		\$	-		
												Equipment Subtotal		\$	-		
												Bond 3%					
<b>X</b>												<b>Total</b>		<b>\$</b>	<b>19,550.00</b>		
Date Approved:																	

	<p><b>TO: San Bernardino International Airport Authority Commission</b></p> <p><b>DATE: April 22, 2026</b></p> <p><b>ITEM NO: 13</b></p> <p><b>PRESENTER: Michael Burrows, Chief Executive Officer</b></p>
---	--

**SUBJECT: CONSIDER AND DISCUSS A REPORT ON THE GREEN ENERGY ELEMENT UPDATE**

**SUMMARY**

In 2020, the San Bernardino International Airport Authority (SBIAA) Commission adopted a 5-Year Green Energy Element. Staff has been coordinating with affected agencies and utilities and has prepared a new 5-Year Update and web page.

**RECOMMENDED ACTION(S)**

Consider and Discuss a Report on the Green Energy Element Update.

**FISCAL IMPACT**

None.

PREPARED BY:	Jillian Ubaldo
CERTIFIED AS TO AVAILABILITY OF FUNDS:	N/A
APPROVED AS TO FORM AND LEGAL CONTENT:	Scott Huber
FINAL APPROVAL:	Michael Burrows

## **BACKGROUND INFORMATION**

A presentation and discussion will be provided at the time of the meeting.

### **Attachments:**

1. PowerPoint
2. 2026 Green Energy Element Update

# Green Energy Element

## IMPLEMENTATION UPDATE

- GREEN ENERGY ELEMENT OVERVIEW
- PROJECT UPDATES
- LEADING ON HYDROGEN PRODUCTION



# GREEN ENERGY ELEMENT

Addressing where we started and where we are are going.

Untapped potential.  
Unrivalled opportunity.  
Unequaled Determination to be different.



# Our Approach

THE PURPOSE OF THE GREEN ENERGY ELEMENT IS TO GUIDE THE DEVELOPMENT, ENHANCEMENTS, AND ULTIMATELY THE CONTINUED IMPLEMENTATION OF ACTIONS THAT WILL REDUCE THE AIRPORT'S GREEN HOUSE GAS EMISSIONS.



# OUR GREEN MODEL

## THE LIST:

- Identify & inventory SBD's emissions sources.
- Provide projections for potential future emissions from stationary sources, based on anticipated growth.
- Provide clear guidance for airport staff, when and how to implement key provisions of the plan.
- Recommend strategies, measures, and actions to achieve additional GHG reductions.
- Demonstrate SBD's commitment to comply with State GHG reduction efforts.
- Define a strategy for turning this plan into action and transparently tracking and reporting progress toward the GHG reduction goals.
- Convert applicable airport vehicles to zero-emission vehicles, including maintenance, passenger, fuel, and support vehicles.
- Review all on-site generators of GHGs for alternative, less-polluting fuels.
- Identify strategies to offset aircraft APU idling and emission capturing.
- Review real estate opportunities at the airport that can accommodate solar installation (battery & hydrogen manufacturing and storage where possible including a Micro-Grid).
- Review landscaping plans to offset carbon output by installing drought tolerant plants, shrubs, and trees where feasible.

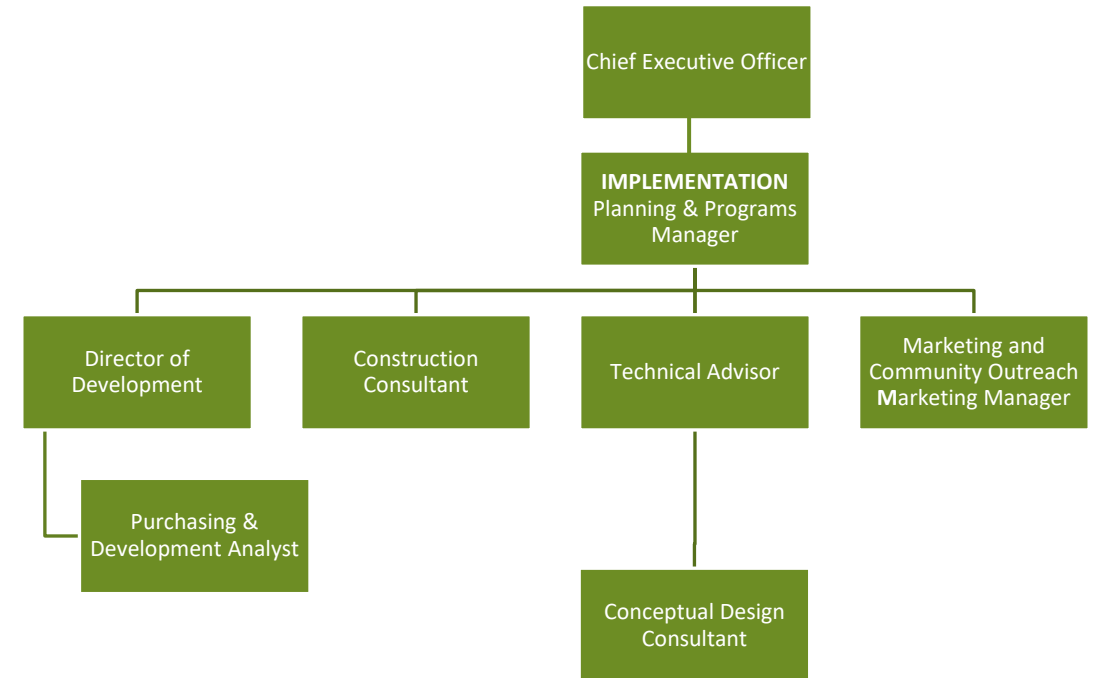

# AIRPORT ENERGY SITUATION

## CURRENT POWER USAGE

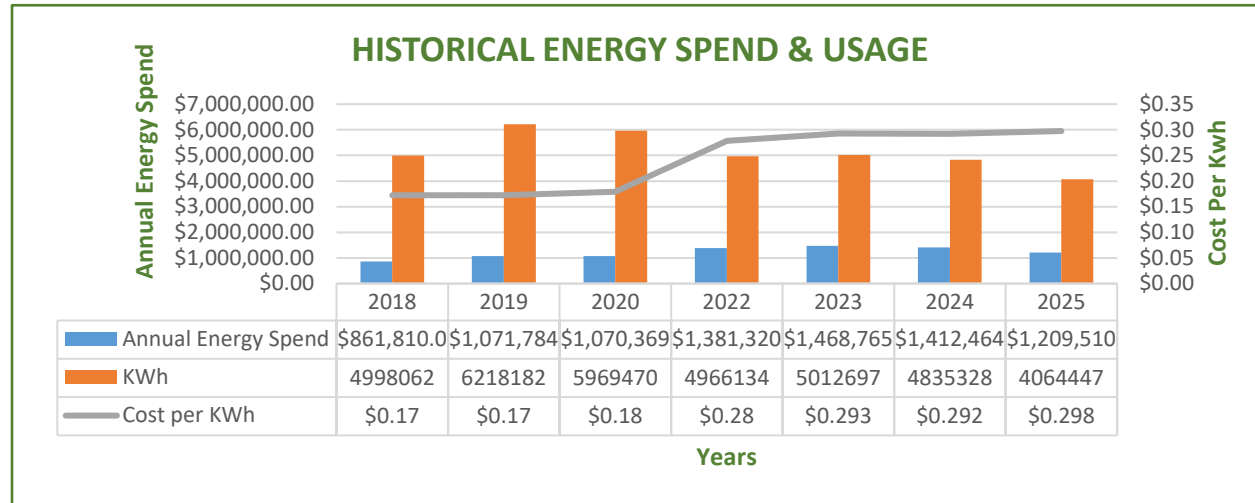

## CURRENT INSTALLED RENEWABLE

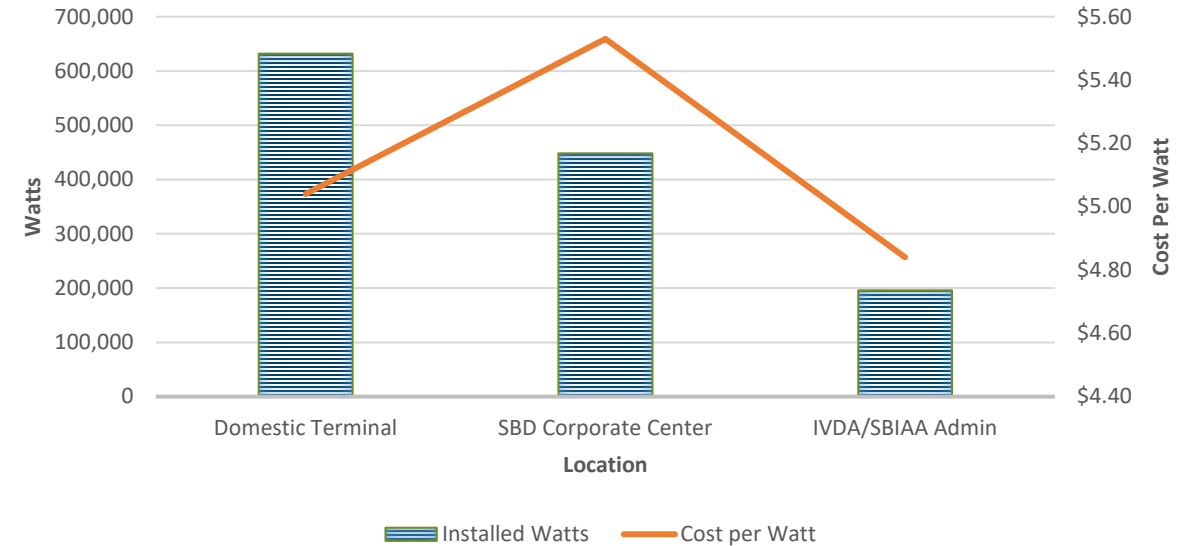

Locations	Installed Watts	Cost Per Watt	Install Date
Domestic Terminal	632,000	\$5.04	2010
SBD Corporate Center	448,000	\$5.53	2011
IVDA/SBIAA Admin	196,000	\$4.84	2010

# SCE “Make Ready” Program & EV Acquisitions

---

## EV CHARGING STATIONS



# The Future of Mobility Is Electric



*If fully utilized the 134 charging ports will offset over 9,628,821 kg of CO2 over a 10-year period*



#	EV Location(s)	Available Parking Spaces	Approved EV Stations	Installed EV Stations	% To Parking Spaces
1	Administration	210	19	19	100%
2	Landfill	50	8	8	100%
3	Luxivair SBD	120	24	24	100%
4	Domestic Terminal	169	20	20	100%
5	Corporate Center	213	25	25	100%
6	Commissary/Innovation	376	38	38	100%
	<b>Total</b>	<b>1138</b>	<b>134</b>	<b>134</b>	<b>100%</b>

**Currently installed Level 2 charging stations through the SC Charge Ready program**



# WORKING THE FUTURE

## Project Score Card

Project	Category	Start Date	Completion Date	Status
Hydrogen Manufacturing Facility	Renewable	Mar-26	Jan-28	In Works
Micro Grid	Renewable	Apr-26	Jan-28	In Works
3-Megawatt Solar Project	Renewable	Feb-2027	Nov-27	In Works

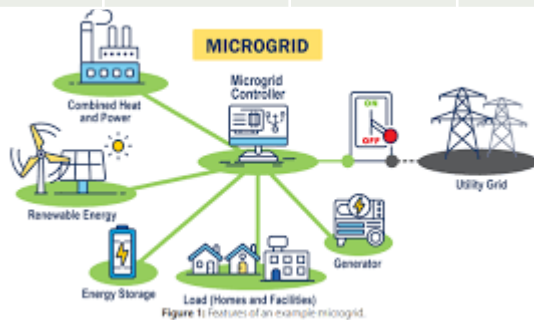
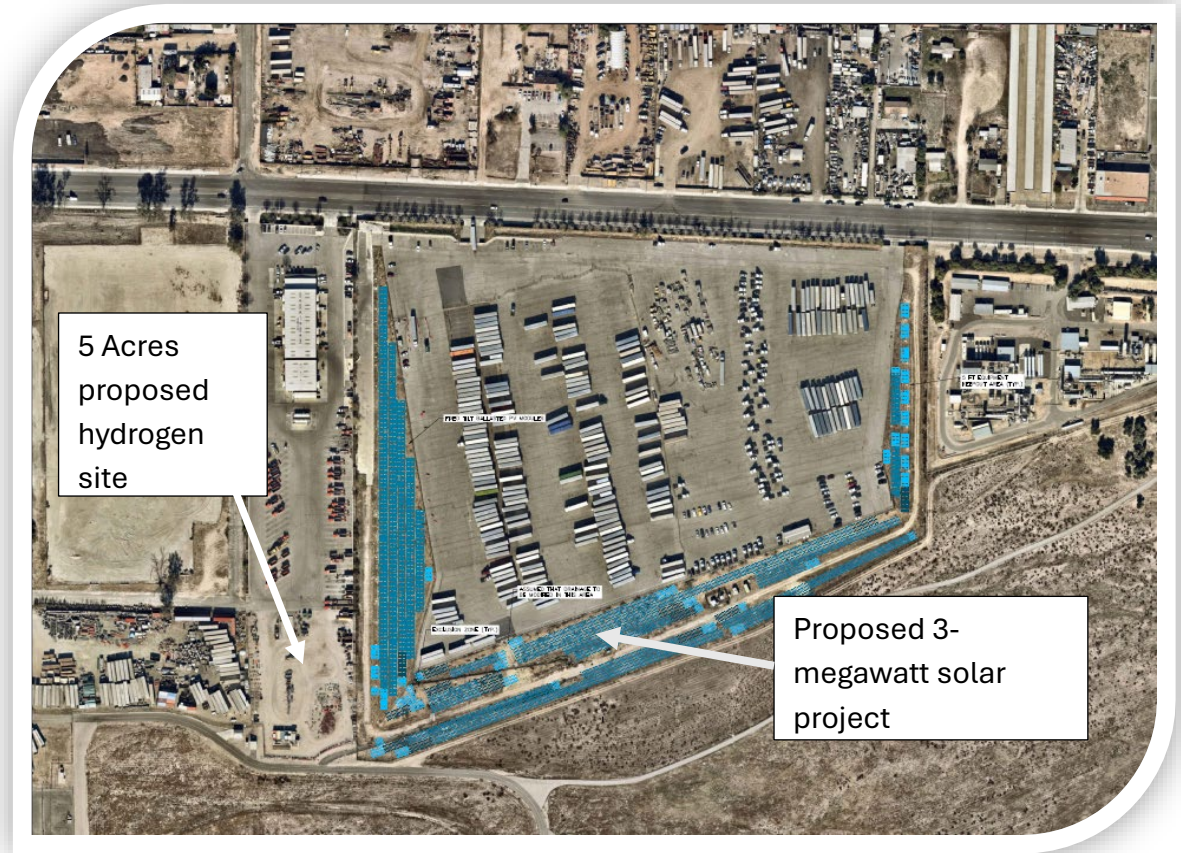

Figure 1: Features of an example microgrid.





San Bernardino International Airport is committed to operating responsibly today while protecting the resources that support tomorrow's travelers, communities, and environment. Through our sustainability program, the Green Energy Element, we are advancing initiatives that reduce environmental impact, enhance operational efficiency, and support long-term economic and community well-being.

From energy efficiency to wildlife stewardship, sustainability is integrated into how we plan, build, and operate. By working collaboratively with tenants, partners, and stakeholders, we aim to create a resilient airport that supports safe, efficient air travel while being a responsible neighbor and environmental steward.

Our sustainability program reflects a long-term commitment to innovation, accountability, and continuous improvement—ensuring our airport remains a vital asset for generations to come.



### Renewable Energy



#### EV Charging Stations

The airport leveraged Edison's EV Charge Ready program to expand electric vehicle charging across its campus. By offsetting infrastructure costs, the program enabled installations for employees, passengers, and fleet vehicles, helping the airport reduce emissions, support clean transportation, and advance its sustainability goals.

STATUS: Completed 2025

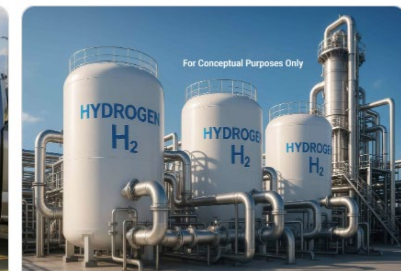

#### Hydrogen Production

The Hydrogen Production and Distribution Facility is designed to produce multiple hydrogen types to meet regional energy and industrial needs. It integrates advanced production, purification, storage, and logistics systems to ensure safe and reliable supply through various delivery pathways, supporting the transition to low-carbon energy.

STATUS: Planned

<https://flysbd.com/corporate/green-energy-element/>

Implementing the “Green Energy Element” is and has been an exciting process with multiple benefits not only for the airport, but also for our community and to our planet!

More to come, we are only getting starting on the journey!!

**QUESTIONS?**



2026

# Green Energy Element



Untapped potential.  
Unrivalled opportunity.  
Unequalled Determination to be  
Different.

Prepared by:

Allawos & Company, LLC  
Global Management Consulting Services

Michael Allawos  
President  
1297 E. Route 66  
Glendora, CA 91740  
(626) 335-5015 | O  
(626) 824-4546 | C

For: San Bernardino International Airport Authority 156



## Statement of Purpose

The Green Energy Element, San Bernardino International Airport's Sustainability Program, is committed to advancing a resilient, efficient, and environmentally responsible airport that supports both regional growth and global climate goals. This initiative seeks to integrate innovative energy solutions that reduce greenhouse gas emissions, optimize resource consumption, and promote long-term environmental stewardship.

Our purpose is to transition airport operations toward clean, renewable energy sources while enhancing operational efficiency and reliability. By investing in solar energy systems, energy-efficient infrastructure, and emerging green technologies, the program aims to significantly reduce the airport's carbon footprint and dependence on non-renewable resources. These efforts align with state and federal sustainability targets while reinforcing the airport's role as a forward-thinking leader in sustainability.

In response to State and Federal sustainability goals, San Bernardino International Airport compiled a GHG emissions inventory and an evaluation of reduction measures that could be adopted. The airport has committed to undertaking the following actions that will reduce GHG emissions associated with its regional (or county-wide) activities:

- Prepare a baseline (2025) GHG emissions inventory for the airport.
- Prepare future (2026, and 2030) GHG emissions forecasts.
- Develop general GHG reduction plans.
- Develop consistent baseline information for use in development of Green Energy Element plan (GEE) for identifying and meeting GHG reduction goals as well as new CARB requirements for airport.

In addition, the Green Energy Element prioritizes collaboration with stakeholders, including local communities, government agencies, and private partners, to foster innovation and shared accountability.

Ultimately, this initiative reflects a commitment to environmental responsibility, economic vitality, and community well-being. By embedding sustainability into its core operations, San Bernardino International Airport strives to serve as a model for sustainable airport development and a catalyst for a cleaner, more energy-efficient future.

Table of Contents

Statement of Purpose .....2

Section 1: Executive Summary.....5

    1.1. Airport Profile .....5

    1.2. Purpose of the Green Energy Element.....5

    1.3. State Mandates Local GHG Emissions Target and Guidelines .....5

    1.4. Emissions Inventory and Forcast.....6

    1.5. Monitoring and Reporting Progress .....6

    1.6. Our Green Model .....7

    1.7. Updating The GHG Inventory and the GEE.....7

    1.8. Financial Model.....7

    1.9. Communication Strategy .....7

    1.10. Management and Operations .....8

    1.11. Summary .....8

Section 2: Emissions Inventory .....9

    2.1. Emissions Overview.....9

    2.2. Methodology .....9

    2.3. Emissions Inventory .....9

    2.4. Emissions Sector for the San Bernardino County .....10

    2.5. Current Airport Vehicle and Equipment (subject to change) Proposed to be Converted to Zero Emissions .....11

    2.6. Current Power Usage at the Airport .....13

    2.7. Renewable Energy Installed.....13

Section 3: Climate Action Strategies .....14

    3.1 Climate Action Strategies .....14

    3.2 Building Energy Efficiency .....14

    3.3 Open-Space Solar Solutions .....15

    3.4 EV Charging Stations .....15

    3.5 Urban Tree, Shrub Planting for Shade and Energy Saving, Carbon Offset .....15

    3.6 On Road.....15

    3.8 Off Road .....15

    3.9 Solid Waste.....16

    3.10 Hydrogen .....16

Section 4: Implementation .....17

    4.1 Implementation .....17

    4.2 Renewable Energy.....17

    4.3 Green Building .....17

    4.4 Energy Efficiency .....17

    4.5 Transportation .....17

    4.6 Water Conservation .....18

    4.7 Landscaping .....18

    4.8 Modified Mixed Use.....18

    4.9 Solid Waste Measures .....19

    4.10 Project Score Card .....19

Section 5: Financial Model.....20

    5.1 Overview of the Financial Model .....20

5.2	Financial Performance Review (historical review).....	20
5.3	Cash Flow.....	20
5.4	Financial Model (Breakeven Calculations) .....	21
5.5	Assumptions .....	21
5.6	Capital Requirements .....	21
<b>Section 6: Management &amp; Operations .....</b>		<b>22</b>
6.1	Management and Operations .....	22
6.2	Management Team .....	22
6.3	Staffing .....	22
6.4	Supply Chain Management .....	22
6.5	Hours of Operation.....	23
6.6	Legal Issues .....	23
6.7	Professional/Advisory Team .....	25
<b>Section 7: Public Participation .....</b>		<b>26</b>
7.1	Public Participation .....	26
7.2	Community Outreach .....	26
<b>Section 8: List of Acronyms.....</b>		<b>27</b>
8.1	List of Acronyms.....	27
<b>Section 9: References &amp; Citations .....</b>		<b>29</b>

## Section 1: Executive Summary

### 1.1. Airport Profile

Conveniently located in the heart of the Inland Empire, close to major freeways, and just 60 miles from Los Angeles, San Bernardino International Airport is strategically positioned to meet growing aviation needs including: cargo, business, general, and commercial aviation by providing competitive rates for aviation companies and local businesses looking to stretch their wings and expand their horizons. With extensive stretches of pristine runway and acres of prime land available for aviation development, San Bernardino International Airport is ready to help our community and region reach new destinations.

### 1.2. Purpose of the Green Energy Element

San Bernardino International Airport's Green Energy Element is dedicated to advancing sustainability and responsible development by reducing environmental impact, increasing energy efficiency, and investing in renewable energy solutions. Through innovative practices and strategic partnerships, the airport aims to lower emissions, conserve resources, and support a cleaner, healthier future for the surrounding community while maintaining safe and efficient operations.

### 1.3. State Mandates Local GHG Emissions Target and Guidelines

California is the first state in America to embrace the challenge of greenhouse gases, with legislation and a comprehensive cap-and-invest program. California legislature passed a number of laws; AB 32 (2006): Reduce GHG emissions to 1990 levels by 2020 (achieved); SB 32 (2016): Reduce GHG emissions 40% below 1990 levels by 2030; Executive Order S-3-05: Reduce emissions 80% below 1990 levels by 2050; SB 100 (2018): Achieve 100% clean electricity by 2045; Renewable Portfolio Standard: 60% renewable electricity by 2030; Carbon Neutrality Goal: Statewide carbon neutrality by 2045. These laws establish limits on greenhouse gas (GHG) emissions for reduction of state-wide emissions. In 2016, California met this goal. The California Assembly and Senate expanded AB 32 with SB 32, mandating a further 40% reduction in GHG emissions from 1990 levels by 2030.

California strengthened its climate framework by extending the cap-and-trade program (now cap-and-invest) through 2030 under AB 398. CARB's 2017 SB 32 Scoping Plan provided a clear, cost-effective roadmap for achieving the state's greenhouse gas reduction goals. Complementary legislation, including SB 100 and SB 350, accelerated clean energy procurement by establishing renewable portfolio standards of 30 percent by 2020 and 60 percent by 2045. AB 2514 supported these efforts by requiring utilities to invest in grid-scale energy storage, enabling greater use of renewable resources. At the same time, AB 617 and SB 535 prioritized environmental justice by directing protections and investments toward vulnerable and disadvantaged communities. Successfully meeting these goals will depend on broad participation and collaboration across all sectors.

The GEE reflects guidelines established in the 2025-2026 Scoping Plan prepared by the California Air Resources Board (CARB). The Scoping Plan, designed to implement the State's GHG emission targets set in Executive Order S-3-05 and, recommends that local governments target a cap of 6 MTCO<sub>2</sub>e (metric tons carbon dioxide equivalent) per capita per year in 2030 and 2 MTCO<sub>2</sub>e per capita per year in 2050 in their CAPs (climate action plans), or in this case our GEE. For perspective, the average per capita CO<sub>2</sub>e for America in 2018 was 16.6 metric tons.

### 1.4. Emissions Inventory and Forecast

The 2020-2030 emissions inventory, and 2030 emissions forecasts in the table below cover direct GHG emissions from sources within the boundaries of SBD and the City of San Bernardino. Indirect emissions associated with the consumption of energy (such as electricity, with no endpoint emissions) that is generated outside the borders of the airport are also included in the table.

The airport’s Business Plan includes closely integrated land use and transportation systems programs, designed to foster a more sustainable community. The table below shows the 2020-2023 emissions inventory and 2030 emissions forecasts, reflecting pre-planned State actions and incorporating results of the traffic forecasts conducted for the Business Plan, as well as additional reductions from other programs contained in the Business Plan.

The table shows that SBD will work towards its targets for 2030 without any additional measures beyond those already included in the Business Plan.

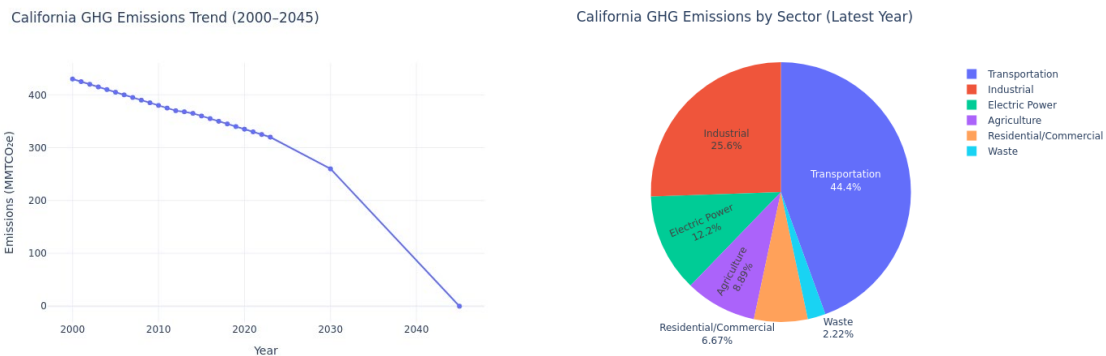

**SOURCE:**

- Historical Emissions (2000–2023): Derived from CARB’s official GHG inventory, which tracks statewide emissions in million metric tons of CO<sub>2</sub> equivalent (MMTCO<sub>2</sub>e).
- Forecast to 2030: Based on CARB’s Scoping Plan pathway to meet the 2030 target of 40% below 1990 levels (260 MMTCO<sub>2</sub>e).
- 2045 Target: California’s statutory goal of carbon neutrality by 2045.
- Sector Breakdown: Percentages reflect CARB’s latest inventory for major sectors:
  - Transportation (40%)
  - Industrial (23%)
  - Electric Power (11%)
  - Agriculture (8%)
  - Residential/Commercial (6%)
  - Waste (2%).

### 1.5. Monitoring and Reporting Progress

The airport periodically monitors and reports emissions as a matter of State and Federal requirements. This monitoring report includes information on the status of the Federal- and State-Level emissions reductions measures. By following our carbon emissions reduction plan will ensure compliance with carbon reduction goals and mandates.

### 1.6. Our Green Model

The Green Energy Element is designed to identify the primary sources of the Airport's emissions and guide the development and implementation of effective actions to reduce greenhouse gas emissions across all operations.

The GEE has been designed to support the following functions:

- Identify & describe SBD's emissions sources.
- Provide projections for future emissions, based on growth.
- Provide clear guidance to airport staff, when and how to implement key provisions of the plan.
- Recommend strategies, measures, and actions to achieve GHG reductions.
- Demonstrate SBD's commitment to comply with State GHG reduction efforts.
- Define a strategy for turning this plan into action and transparently tracking and reporting progress toward the GHG reduction goals.
- Develop strategies for reducing solid waste to landfills.
- Convert all airport vehicles to zero-emission vehicles, including maintenance, passenger, fuel, and support vehicles. Review all on-site generators of GHGs for alternative, less-polluting fuels.
- Find strategies to eliminate aircraft APU idling and emission capturing.
- Review all real estate at the airport that will accommodate solar installation (battery & hydrogen manufacturing and storage where possible).
- Review landscaping plans to offset carbon output by installing plants, shrubs, and trees.

### 1.7. Updating The GHG Inventory and the GEE

The Airport will update the GHG inventory periodically. If an updated inventory reveals that SBD is not making adequate progress toward meeting the GHG target, or that new technologies and programs emerge that warrant inclusion in the GEE, the Airport will adjust the GEE by modifying, adding, and/or replacing policies in the Business Plan or elsewhere, or incorporating optional measure(s) to further reduce emissions.

### 1.8. Financial Model

SBD will implement the Green Energy Element in a fiscally reasonable and responsible manner by seeking out grant opportunities from Southern California Air Quality Management District (AQMD) as well as other State and federal agencies including SCE to help offset the cost of building such solutions that meet our aggressive goals. Long term savings and meeting the goal of reducing ongoing airport operation costs, will further our enthusiasm for "greening" our operations.

### 1.9. Communication Strategy

Residents and business leaders may participate in the GEE through participation in the airport workshops or through comments at publicly held meetings. Community members can provide valuable input that may be used in selecting methods for GHG reductions. Outreach efforts may include online surveys, community open houses, community workshops, presentations, group activities, and online comments. Information about the GEE Plan is available on the airport's website to provide the public with information on past and upcoming events, as well as links to documents and reports. The information gathered from these meetings and surveys may be used to formulate the GEE Plan policies upon which the GHG reduction strategies and actions are derived. As the airport shares information, community members will provide feedback, both positive and constructive. By committing to a continuous dialogue, sharing up-to-date



information, and increasing opportunities for well-paying jobs, this program will ensure that the San Bernardino International Airport remains a good neighbor and community partner

**1.10. Management and Operations**

Airport personnel are responsible for implementing the Green Energy Element, and coordinating with tenants, contractors, and external partners to carry out reduction strategies. Staff integrates sustainability practices into daily operations, capital projects, and maintenance activities, ensuring consistency across all departments. Ongoing training and collaboration help build internal capacity and accountability, while designated staff monitor performance, report on progress, and recommend adjustments to improve outcomes.

**1.11. Summary**

SBD is confident in our plans moving forward to meet the objectives and initiatives laid out within this “Green Energy Element” plan.

Section 2: Emissions Inventory

**2.1. Emissions Overview**

The SBD Emissions Inventory identifies the major sources and the overall magnitude of greenhouse gas (GHG) emissions in and around the airport, pursuant to Sections 15183.5(b)(1)(A) and 15183.5(b)(1)(C) of the state CEQA Guidelines. As part of the Green Energy Element (GEE) preparation effort, this 2020 GHG inventory was prepared to provide a recent measure of emissions and is summarized in this chapter.

The inventory follows the standards developed by the International Council for Local Environmental Initiatives (ICLEI) for community GHG inventories. The inventory methodology is described first, followed by inputs and results.

**2.2. Methodology**

The emissions inventory covers direct GHG emissions from sources within the boundaries of the City of San Bernardino and to an extent the San Bernardino International Airport, including fuel combusted and solid waste generated within the city. Indirect emissions associated with the consumption of energy (such as electricity, with no end point emissions) that is generated outside the borders of the city and the airport are also included. The emissions inventory tallies emissions from ten sectors:

- Residential (adjacent to the Airport).
- Commercial.
- Industrial.
- Transportation.
- Solid waste.
- Water.
- Wastewater.
- Off-Road Equipment.
- Public Lighting; and
- Agriculture.

**2.3. Emissions Inventory**

The closest air pollutant monitoring stations to the general study area are identified in the table below, along with a tabulation of recent monitoring data for O<sub>3</sub>, PM<sub>2.5</sub>, and oxides of nitrogen (NO<sub>x</sub>) from the California Air Resources Board (CARB) and the U.S. EPA.

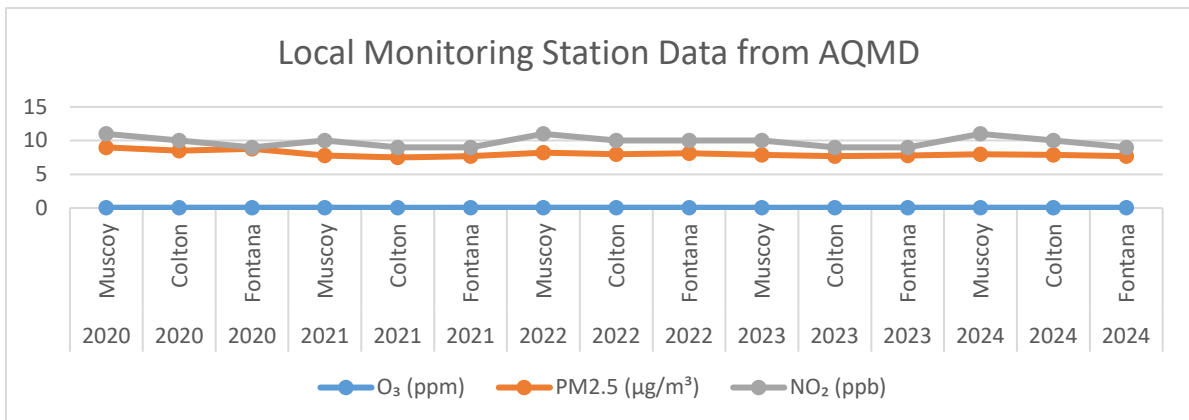

SOURCE: [www.EPA.gov](http://www.EPA.gov)

## 2.4. Emissions Sector for the San Bernardino County

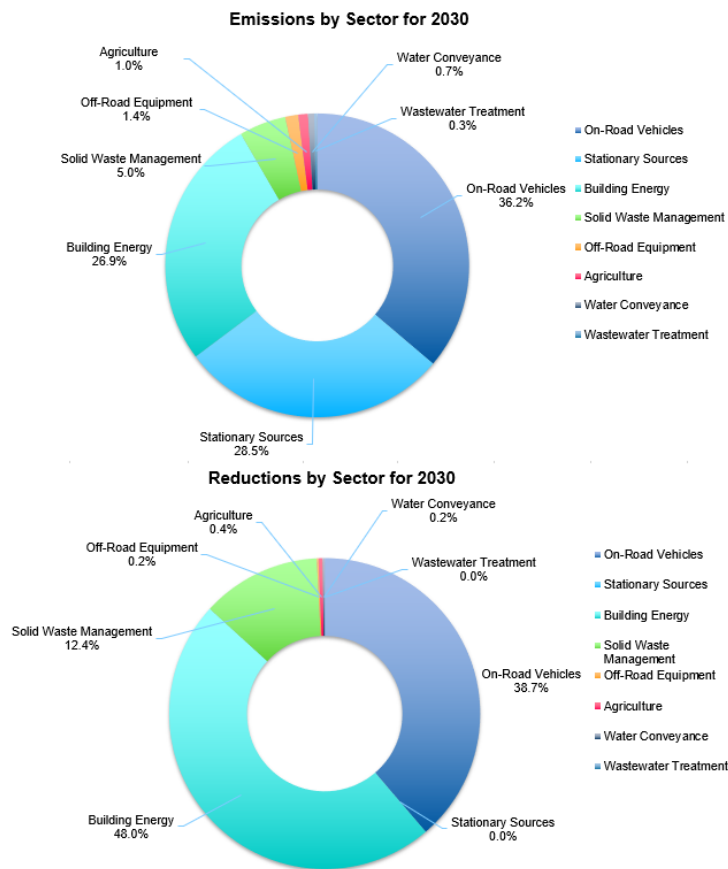
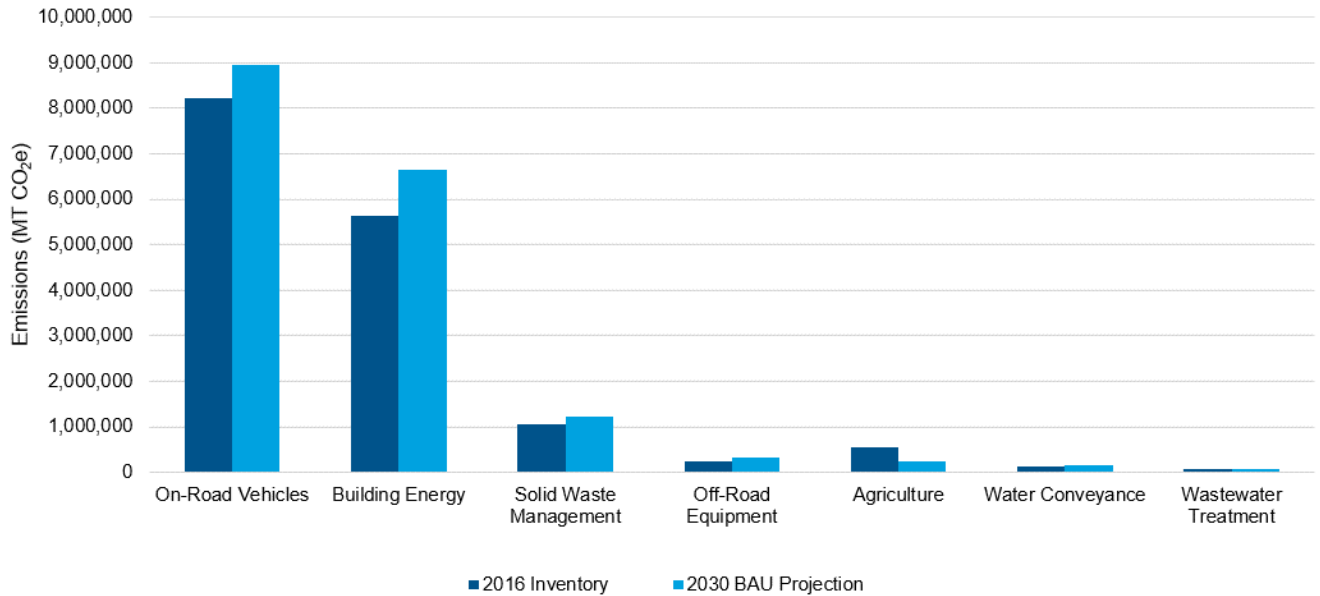

SOURCE: [Regional Greenhouse Gas Reduction Plan \(2021\) - SBCTA](#)

2.5. Current Airport Vehicle and Equipment (subject to change) Proposed to be Converted to Zero Emissions

Year	Make	Model	Replacement
<b>Administration</b>			
2005	Ford	Starcraft E-450 Mini Bus	
2008	Ford	Dodge Sprinter 12 Passenger Van	
2008	Ford	Escape	
2008	Ford	Escape	
<b>Airport Maintenance - Maintenance, Fleet, Grounds</b>			
1978	GMC	Sierra Flatbed/Rail Truck	
1982	Green	Green Forklift	
1983	John	John Deere Road Grader	
2001	GMC	Sierra ¾ Ton CNG	
1985	International	1-1/2 Ton Truck s1600 Flatbed	
1988	Chevrolet	350 Tommy/Lift	
1989	Bobcat	Bobcat	
1990	Case	Case Frontend Loader	
2001	Ford	F-450 Heavy Duty Dump Truck	
2001	GMC	C250 Utility Irrigation Truck	
2005	Chevrolet	2500HD Utility Truck	
2005	Ford	F-150 4X4 Truck	
2006	Chevrolet	Silverado (Fueller)	
2007	Ford	F-150 Pickup Truck	
2007	Ford	F-150 Pickup Truck	
2007	Ford	F-150 Pickup Truck	
2007	NPR	Nite- Hawk (Isuzu) Sweeper	
2008	Ford	F-250 Utility Truck	
2008	Ford	F-250 Utility Truck	
2009	Ford	Escape MAINT1	
2009	Ford	Escape SCH1	
2009	Ford	Ford Escape	
2016	Ford	Ford Transit #31	
2017	Ford	F-150 Pickup truck	
2018	Ford	Ford Transit #32	
2018	Ford	Ford Transit #33	
2007	John Deere	Tractor/Backhoe/Loader	
2008	Dodge	12 Passenger / Cargo Van	
1986	Vermier	Trailer / Backhoe/Loader	
<b>ARFF Vehicle</b>			
1988	Oshkosh	ARFF Vehicle	
1995	Oshkosh	ARFF Vehicle	
1989	Ford	F-350 Fire Truck	
2000		ARFF Airport Crash Truck R9	
<b>Airport Generators</b>			
	Emergency Gen	Emergency Gen. 40HP, 120/208,104AMP	
	Emergency Gen	Emergency Gen. 200HP, 120/208,520AMP	
	Emergency Gen	Emergency Gen. 1000HP, 277/480,1127AMP	

	Emergency Gen	Emergency Gen.600HP, 2400, 183AMP	
	Emergency Gen	Emergency Gen. 30HP, 120/240,87AMP	
	Emergency Gen	Emergency Gen. 40HP, 120/208,104AMP	
Airport Security			
2010	Ford	Crown Victoria	
2005	Ford	Crown Victoria	
2006	Ford	Crown Victoria	
2001	Ford	Crown Victoria	
2015	Ford	Taurus	
2015	Ford	Taurus	
2015	Ford	Taurus	
2017	Ford	Explorer	
2017	Ford	Explorer	
2018	Ford	Explorer	
2018	Ford	Explorer	
Luxivair SBD			
1989	Wollard	TC-886-DL Belt Loader	
1987	Wollard	TC-886 Belt Loader	
1981	GMC	Red Dye Diesel 1100-Gal Fuel Truck	
1982	Mark	Lift	
1988	Ford	Fuel Truck 2,500 Avgas	
1992	Ford	F-350 White Stair truck	
1999	Chevrolet	Suburban	
2003	Chevy	Silverado C1500	
2007	American LaFrance	American LaFrance Fueler 10,000 Jet A	
2007	American LaFrance	Fueler Truck 10,000 Jet A	
2008	International	International 4000 Series Fueler 3,000 Jet A	
2008	Isuzu	NPR Fueler Avgas 1000k	
2009	International	7000 Series Fueler 5,000 Jet A	
2015	Volkswagen	2015 Volkswagen Crew Car Executive	
2021	Lincoln	2021 Lincoln Aviator	
2017	Lincoln	Lincoln Navigator	
2007	Isuzu	NPR	
1999	GM	Suburban	
2003	GM	Silverado	
2021	Lincoln	2021 Lincoln Navigator	
	Gem Cart	Gem Cart (6 pax)	
2018	SkyMark	SkyMark Jet A Fueler 10K	
2018	SkyMark	SkyMark Jet Fueler 10k	
2019	SkyMark	SkyMark Jet Fueler 10k Jet A	
2023	SkyMark	SkyMark Jet Fueler 10K Jet A	
2022	SkyMark	SkyMark Jet Fueler 15K Jet A	
2022	SkyMark	SkyMark Jet Fueler 15K Jet A	
2017	TLD	TMX 150-16 Tug	

2021	TLD	ABS—580-E Stair Truck	
2023	TLD	JST-30-E Tug	
2021	TLD	LSP-900-V-E Lav Truck	
1989	BT345	GTG-362 Tug	
1990	Hobart	TC-886-DL Belt Loader	
		K-Loader 40000 lbs. capacity	

2.6. Current Power Usage at the Airport

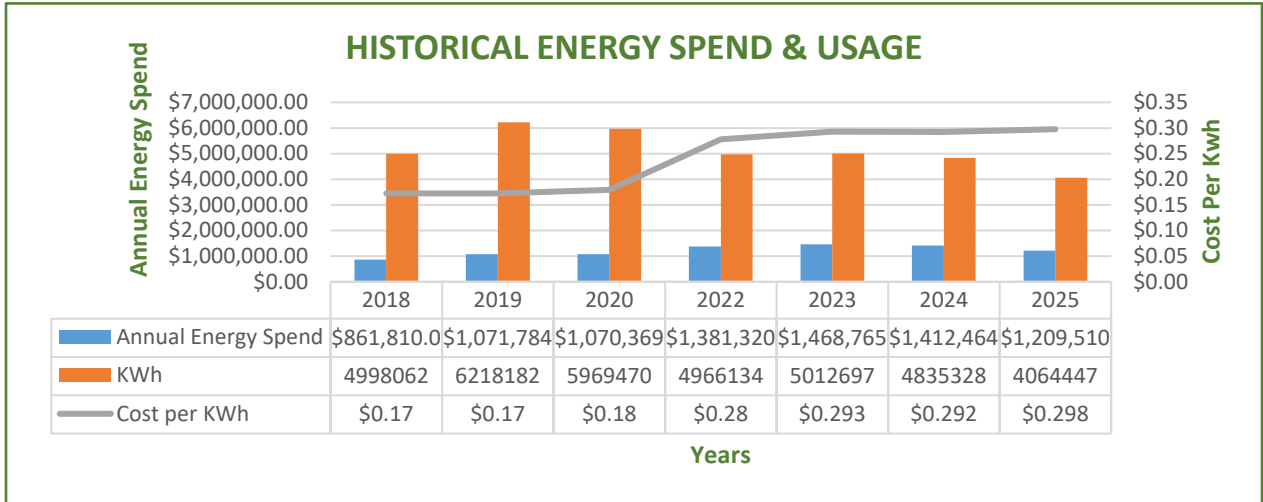

2.7. Renewable Energy Installed

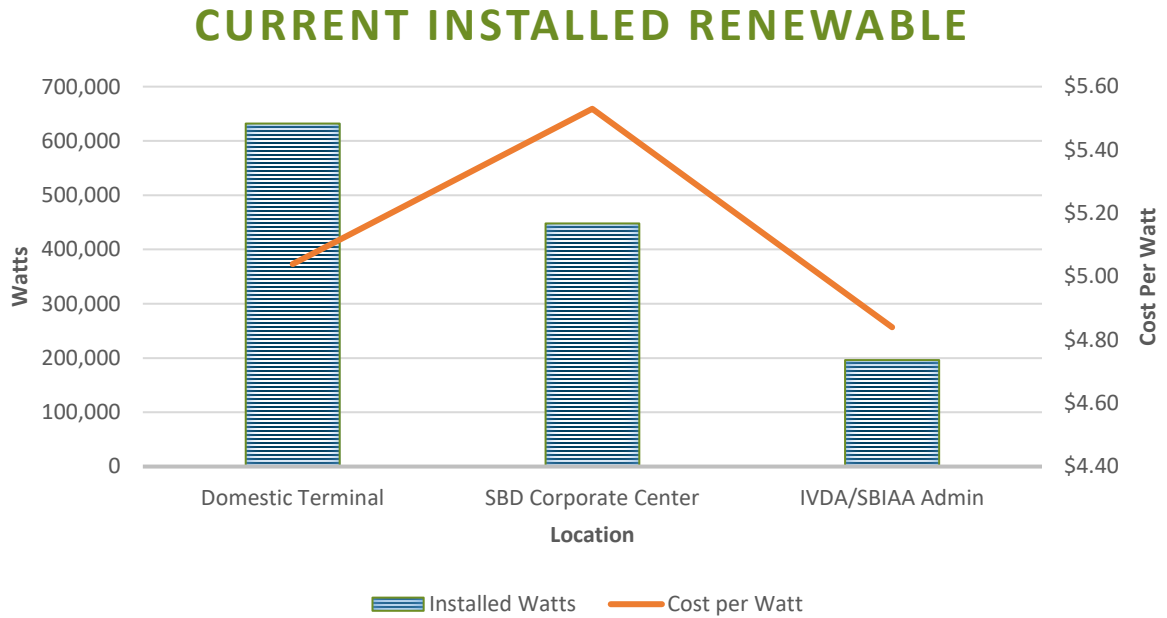

Locations	Installed Watts	Cost Per Watt	Install Date
Domestic Terminal	632,000	\$5.04	2010
SBD Corporate Center	448,000	\$5.53	2011
IVDA/SBIAA Admin	196,000	\$4.84	2010

## Section 3: Climate Action Strategies

### 3.1 Climate Action Strategies

This section summarizes key programs that support SBD’s sustainability measures. In addition to state level measures, the airport selected a variety of measures across nearly all sectors, including a Sustainability Performance Standard for new development. The airport’s business plan includes programs that broadly support energy efficiency and sustainability.

### 3.2 Building Energy Efficiency

- **Conserve Energy:**
  - Reduce electricity use by 10% as an example for other businesses to follow.
  - Consider enrollment in:
    - Community Energy Efficiency Program (CEEP), which provides incentives for builders who attain energy savings 30% above the National Model Energy Code.
    - Energy Star Program, which is sponsored by the United States Department of Energy and the Environmental Protection Agency and encourages superior energy efficiency by residents and businesses.
    - CA State’s Energy Efficiency and Demand Reduction Program, which offers rebates and incentives to agencies and developers who reduce energy consumption and use energy efficient fixtures and energy-saving design elements.
  - Require energy audits of existing public structures and encourage audits of private structures, identifying levels of existing energy use and potential conservation measures.
  - Investigate energy-efficient retrofitting of existing buildings throughout the airport.
  - Consider programs that award incentives to projects that install energy conservation measures, including technical assistance and possible low-interest loans for surrounding business.
  - Educate staff and surrounding partners regarding the need for energy conservation, environmental stewardship, and sustainability techniques, and about systems and standards that are currently available for achieving greater energy and resource efficiency, such as the U.S. Green Building Council’s LEED standards for buildings.
- **Lighting Efficiency:** Encourage and promote the use of energy-efficient (U.S. Department of Energy “Energy Star®” or equivalent) lighting fixtures, light bulbs, and compact fluorescent bulbs in residences, commercial, and public buildings, as well as in traffic signals and signs where feasible.
- **All Electric Buildings:** Encourage energy-efficient retrofitting of existing buildings throughout the Airport.
- **Renewable Energy:** Encourage increased use of passive and active solar design in existing and new developments: (e.g., orienting buildings to maximize exposure to cooling effects of prevailing winds, day lighting design, natural ventilation, space planning, thermal massing and locating landscaping and landscape structures to shade buildings).
- **Solar Energy for Warehouse Space:** Encourage increased use of passive and active solar design in existing and new development (e.g., orienting buildings to maximize exposure to cooling effects of

prevailing winds, day lighting design, natural ventilation, space planning, thermal massing and locating landscaping and landscape structures to shade buildings).

- **Renewable Energy:** Existing Commercial/Industrial: Encourage increased use of passive and active solar design in existing and new development (e.g., orienting buildings to maximize exposure to cooling effects of prevailing winds, daylighting design, natural ventilation, space planning, thermal massing and locating landscaping and landscape structures to shade buildings).
- **Rooftop Gardens:** Consider planting gardens on rooftops to add cooling shade, to capture and recycle rainwater and to provide additional ecosystems for wildlife and/or food for people.

### 3.3 Open-Space Solar Solutions

Open space identification: Encourage and identify open space locations that will support the use of solar energy capture and conversion with the appropriate battery or other means of storage for use by the airport or other related entities of the airport.

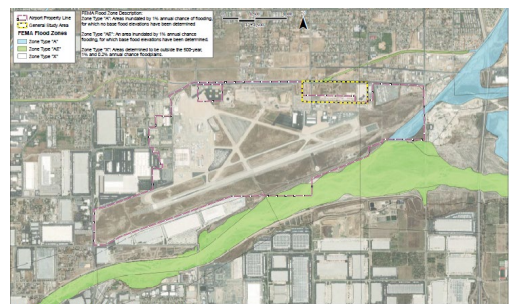

### 3.4 EV Charging Stations

Six Charging station locations: Encourage and identify convenient locations for EV charging stations in and around airport facilities. These charging stations may be used for all vehicles owned by or in support of the airport. In total the airport has installed 134 charging stations.



### 3.5 Urban Tree, Shrub Planting for Shade and Energy Saving, Carbon Offset

Conserve scarce energy resources: Encourage increased use of landscaping to offset carbon emissions with the planting of drought tolerant trees and shrubs designs in existing and new development.

### 3.6 On Road

Alternatively Fueled Transit Fleets: Replace all GHG-producing vehicles (e.g. passenger, maintenance, busses, waste, and re-fueling) with electric.



### 3.8 Off Road

Replacing traditional off road ground support vehicles (Stair trucks, Waste haulers, and Tugs) from traditional fuels with electric support vehicles is both convenient and plant safe.





### 3.9 Solid Waste

**Waste Diversion:** Continue to reduce the amount of solid waste that must be disposed of in area landfills and be consistent with the County Solid Waste Management Plan and State law.

### 3.10 Hydrogen

Hydrogen can and is an important solution for global and local pollution reductions. The airport has been working diligently on exploring the manufacturing of hydrogen on-site in support of internal and external needs. The airport understands and takes the responsibility seriously to be a good regional partner for sustainable energy solutions. 2026 is planned for the launching of a new regional hydrogen production facility at the airport.

## Section 4: Implementation

### 4.1 Implementation

In addition to the potential programmatic measures contained in this Green Energy Element, the following is a non-exclusive list of potential additional measures that can be applied at the project level to reduce greenhouse gas emissions. It should be noted that these measures are not essential for the airport to meet its GHG reduction targets but are presented here for information purposes. Sources for additional potential measures include those listed in CAPCOA's "CEQA and Climate Change, Evaluating and Addressing Greenhouse Gas Emissions from Projects Subject to the California Environmental Quality Act (January 2008)"; the Attorney General's "Addressing Climate Change at the Project Level"; OPR's "CEQA and Climate Change: Addressing Climate Change Through California Environmental Quality Act (CEQA)"; and SANBAG's "Regional Greenhouse Gas Reduction Plan (2014)".

### 4.2 Renewable Energy

- Provide onsite renewable energy system(s). Nonpolluting renewable energy sources include solar with onsite storage, through battery, hydrogen, or other means.
- Including in new buildings, facilities to support the use of low/zero carbon fueled vehicles, such as the charging of electric vehicles from green electricity sources.
- Provide solar water heaters.

### 4.3 Green Building

- Meet recognized green building and energy efficiency standards such as LEED and ENERGY STAR.
- Incorporate materials which are resource efficient, recycled, with long life cycles and manufactured in an environmentally friendly way.

### 4.4 Energy Efficiency

- Exceed Building Code (Title 24) mandatory efficiency requirements by 15% or more.
- Install light colored "cool" roofs (e.g., Energy Star roofing) or other highly efficient roofing materials.
- Install a vegetated ("green") roof that covers at least 50% of roof area.
- Design projects to maximize solar orientation (i.e., 75% or more building face north or south; include roof overhangs that block high summer sun, but not lower winter sun, from penetrating south-facing windows.
- Plant trees and vegetation near structures to shade buildings and reduce energy requirements for heating/cooling.
- Install energy-reducing ceiling/whole-house fans.
- Install energy efficient lighting (e.g., light emitting diodes (LEDs), heating and cooling systems, appliances, equipment, and control systems. (e.g., Energy Star)
- Install energy-reducing programmable thermostats that automatically adjust temperature.

### 4.5 Transportation

- Develop commuting reduction plans that encourage employees who commute alone to consider alternative transportation modes.
- Explore creating an online ridesharing program that matches potential carpoolers immediately through email.
- Provide Zero-Emission shuttle service or public transit incentives such as transit passes to decrease work-related auto trips as well as passenger trips.

- Provide “end-of-trip” facilities including showers, lockers, and changing space (nonresidential projects).
- Incorporate public transit into project design.
- Incorporate bicycle lanes, routes and facilities into street systems, new subdivisions, and large developments.
- Provide amenities for non-motorized transportation, such as secure and convenient bicycle parking.
- Provide plentiful short- and long-term bicycle parking facilities (non-residential projects).
- Create pedestrian (and/or bicycle) access network that internally links all uses and connects to all existing/planned external streets and pedestrian (and/or bicycle) facilities contiguous with the project site.
- Provide a parking lot design that includes clearly marked and shaded pedestrian pathways between transit facilities and building entrances.
- Convert all vehicles to Zero-Emission including but not limited, maintenance, shuttle, waste haulers, and fuel (electric and or Hydrogen).
- Provide parking for EVs/CNG vehicles.
- Install EV charging facilities.
- UAS systems integration for airport and surrounding use will be incorporated to reduce miles traveled.

#### 4.6 Water Conservation

- Install water-efficient fixtures and appliances such as low-flow fixtures, dual flush toilets, and other water-efficient appliances.
- Install water-efficient irrigation systems and devices, such as soil moisture-based irrigation controls and use water-efficient irrigation methods.
- Implement low-impact development practices that maintain the existing hydrology of the site to manage storm water and protect the environment.
- Incorporate recycled/reclaimed water for landscape irrigation and other non-potable water use needs (purple pipe).
- Incorporate rain barrels (with the support of vector control) and gray water systems for landscape irrigation.

#### 4.7 Landscaping

- Install native and drought-tolerant plant materials into landscapes.
- Incorporate into landscapes: drought resistant native trees, trees with low emissions (low carbon turnover), and high carbon sequestration potential.
- Provide parking lot areas with 50% tree cover within 10 years of construction, in particular low emitting, low maintenance, native drought resistant trees. This greatly reduces the urban heat island effect.
- Convert where possible all landscaping and facility maintenance equipment to zero-emissions.

#### 4.8 Modified Mixed Use

- Promote mixed-use development projects. These are predominantly characterized by properties on which various uses, such as office, commercial, institutional, but not residential, are combined in a single building or on a single site in an integrated development project with functional interrelationships and a coherent physical design; or projects that have at least two of the following on site and/or offsite within one-half mile, and retail development, office, transit, park, or open space.

- Provide on-site shops, commercial, and services for employees, as permitted by zoning and development standards.

#### 4.9 Solid Waste Measures

- Reuse and recycle construction and demolition waste (including, but not limited to, soil, vegetation, concrete, lumber, metal, and cardboard).
- Provide interior and exterior storage areas for recyclable and green waste and adequate recycling containers located in public areas.
- Provide education and publicity about reducing waste and available recycling services.

#### 4.10 Project Score Card

- INTERNAL USE: SBD will list and track all GEE projects that have been identified that meet the goals of this Green Energy Element plan with costs, estimated and actual completion dates, as well as responsible parties to complete the task(s).

Project Score Card				
Project	Category	Start Date	Completion Date	Status
Hydrogen Manufacturing Facility	Renewable	Mar-26	Jan-28	In Works
Micro Grid	Renewable	Apr-26	Jan-28	In Works
3-Megawatt Solar Project	Renewable	Feb-2027	Nov-27	In Works

Section 5: Financial Model

**5.1 Overview of the Financial Model**

This section provides an overview of the financial model, historical data, and capital required, for implementing the GEE, as well as forecast information and the cash investment plan. SBD is relying on historical project costs to provide a foundation to fiscally move forward from in a responsible manner.

SBD is focusing its fundraising efforts on implementing our Green Energy Element on applying for grants at both at the Federal and State levels. Possible funding sources include: SCAQMD, CRC AB2766, CARB for CAP & Invest funds, and Clean Transportation Funding. Southern California Edison is also a valuable partner for additional services and funding opportunities such as the “Charge Ready” and “Charge Ready Transport” programs that has paid for infrastructure for EV charging.



#	EV Location(s)	Available Parking Spaces	Approved EV Stations	Installed EV Stations	% To Parking Spaces
1	Administration	210	19	19	100%
2	Landfill	50	8	8	100%
3	Luxivair SBD	120	24	24	100%
4	Domestic Terminal	169	20	20	100%
5	Corporate Center	213	25	25	100%
6	Commissary/Innovation	376	38	38	100%
	<b>Total</b>	<b>1138</b>	<b>134</b>	<b>134</b>	<b>100%</b>

**Currently installed level 2 EV charging stations through the SCE Charge Ready program.**

The initiative was and continues to eventually make our program(s) self-funded once certain infrastructure is put into place, creating positive cash flows for other green solutions, as well as ongoing maintenance.

**5.2 Financial Performance Review (historical review)**

💰 SBD has installed solar facilities at its airport offices and have found that over several years the system has been a net positive in cash flow, thus paying for its initial installation.

**5.3 Cash Flow**

As SBD rolls out the GEE, identifying site-specific plans as well as overall goals, we will have a better idea of the cash flow requirements to build and maintain these systems.





#### 5.4 Financial Model (Breakeven Calculations)

Our financial model takes into account the revenue, minus cost of goods/mitigation efforts, and expenses, with a forecasted profit based on a “best-case scenario”. This will give us a good indication of how the financial model of the GEE will work. SBD’s goal is simply not too break-even, but to make this element a profit center, while reducing our carbon footprint.

#### 5.5 Assumptions

Our assumptions are being validated that SBD is being successful in raising the required funds needed to implement our Green Energy Element over time.

#### 5.6 Capital Requirements

Currently SBD is moving through the RFQ process for selected projects to establish an updated baseline requirement for capital. It is anticipated that the ongoing projects required to implement the Green Energy Element will need tens of millions of dollars in funding. Seed funding won from various governmental agencies, is expected to launch this Element into a self-funded plan.

## Section 6: Management & Operations

### 6.1 Management and Operations

SBD is a lean operation, with highly qualified personnel that are motivated to provide the best service for their internal and external customers.

Please see an abbreviated listing of management and operational staff that will help implement this Green Energy Element below.

### 6.2 Management Team

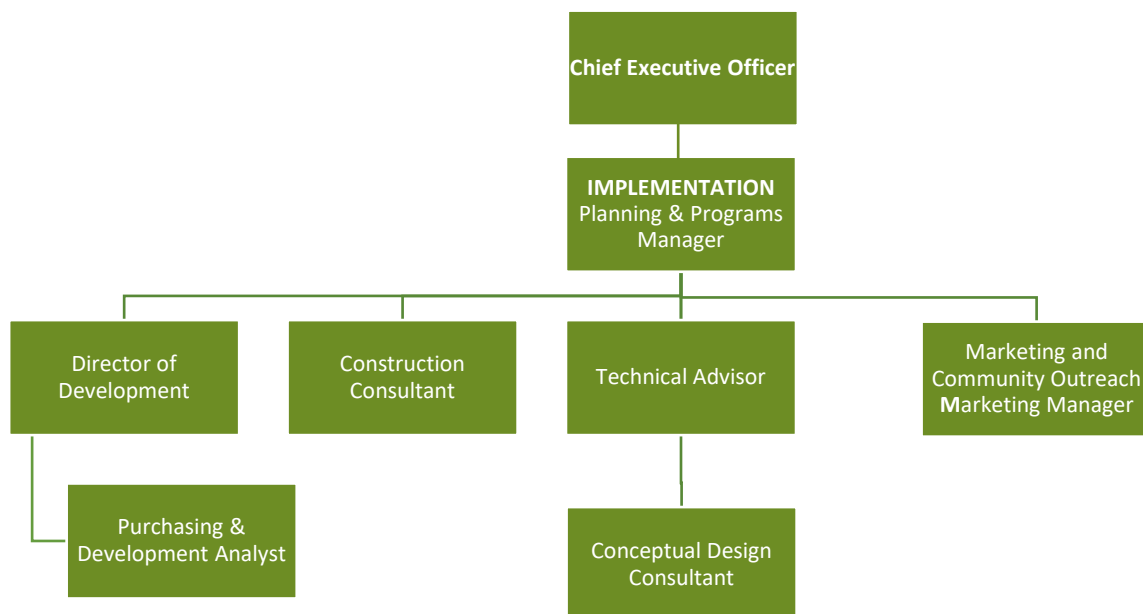

### 6.3 Staffing

Staff for the Green Energy Element plan involve the executive management, project management, purchasing, and our maintenance facilities personnel. All our staff are highly experienced in these, and similar types of activities.

Most of the buildouts will be by means of outsourcing to independent contractors via the competitive bidding process, and P3's (public private) allowing staff to play the role of project oversight.

### 6.4 Supply Chain Management

Since most of the implementation of this Green Energy Element will be performed by independent contractors, our supply chain will be at a minimum. However, we will utilize the following major supply chains:



- |  |  |
|--|--|
| <ol style="list-style-type: none"> <li>1. Raw material acquisition</li> <li>2. Product Development, Design, Multi-phase pre-fabrication, etc.</li> <li>3. Manufacturing</li> <li>4. Tracking systems</li> <li>5. Shipping</li> </ol> | <ol style="list-style-type: none"> <li>6. Brokerage/Jobber</li> <li>7. Warehousing</li> <li>8. Shipping to Wholesalers</li> <li>9. Retail Broker</li> <li>10. Retail Sales</li> <li>11. Back-up suppliers</li> </ol> |
|--|--|

### Location/Facilities

San Bernardino International Airport Authority  
1601 E. Third Street  
San Bernardino, CA 92408

### 6.5 Hours of Operation

As an international airport, we operate around the clock, 24/7.

### 6.6 Legal Issues

Legal issues concerning this Green Energy Element include, but are not limited to the following:

- Licensing/bonding.
- Business licensing for contractors and sub-contractors.
- City, County, State, or Federal requirements.
- Permits.
- Environmental regulations.

- Zoning or building codes.
- Insurance coverage.
- Unions.

#### Relationship with the California Environmental Quality Act.

The California Environmental Quality Act (CEQA) is a statute that requires local agencies to identify significant environmental impacts of their actions and avoid or mitigate those impacts, if feasible. In 2007, California’s lawmakers enacted SB 97, which expressly recognizes the need to analyze GHG emissions as part of the CEQA process. SB 97 required the Governor’s Office of Planning and Research (OPR) to develop recommended amendments to address GHG emissions as an environmental effect.

In 2010, OPR’s amendments to the CEQA guidelines addressing GHG emissions became effective. Lead agencies are now obligated to describe, calculate, or estimate the amount of GHG emissions resulting from a project, by using a model or methodology to quantify GHG emissions resulting from a project or relying on a qualitative analysis or performance-based standards. The lead agency should determine whether a project’s GHG emissions significantly affect the environment by considering whether the project’s emissions, as compared to the existing environmental setting, exceeds a threshold of significance that the lead agency determines applies to the project, and the extent to which the project complies with the regulations or requirements adopted to implement a statewide, regional, or local plan for the reduction or mitigation of GHG emissions. In addition, the lead agency is required to impose feasible mitigation to eliminate or substantially reduce significant effects. The airport is also regulated by the Federal Government including NEPA (National Environment Policy Act.) requirements.

5 15183.5(b) of CEQA Guidelines states, “Plans for the Reduction of Greenhouse Gas Emissions. Public agencies may choose to analyze and mitigate significant greenhouse gas emissions in a plan for the reduction of greenhouse gas emissions or similar document. A plan to reduce greenhouse gas emissions may be used in a cumulative impacts analysis as set forth below. Pursuant to sections 15064(h)(3) and 15130(d), a lead agency may determine that a project’s incremental contribution to a cumulative effect is not cumulatively considerable if the project complies with the requirements in a previously adopted plan or mitigation program under specified circumstances.”

The GEE will help the airport with compliance with CEQA Guidelines Section 15183.5(b): Tiering and Streamlining the Analysis of Greenhouse Gas Emissions<sup>5</sup>, which became effective in 2010.

The required elements of a CAP, or in our case GEE, as cited in the guidelines, state that a plan for the reduction of GHG emissions should:

- Quantify greenhouse gas emissions, both existing and projected over a specified time-period, resulting from activities within a defined geographic area.
- Establish a level, based on substantial evidence, below which the contribution to greenhouse gas emissions from activities covered by the plan would not be cumulatively considerable.
- Identify and analyze the greenhouse gas emissions resulting from specific actions or categories of actions anticipated within the geographic area.
- Specify measures or a group of measures, including performance standards, that substantial evidence demonstrates, if implemented on a project-by-project basis, would collectively achieve the specified emissions level.
- Establish a mechanism to monitor the plan’s progress toward achieving the level and to require amendment if the plan is not achieving specified levels; and

- Be adopted in a public process following environmental review.

The GEE intends to fulfill these requirements. The GEE also contains a Project Review Score Card, which allows for streamlined review of GHG emissions for projects that demonstrate consistency with the GEE, as described in CEQA Guidelines Section 15183.5(b).

#### 6.7 Professional/Advisory Team

##### Management Consultant

Allawos & Company, LLC.

Michael Allawos

1297 E. Route 66

Glendora, CA 91740

Office line: (626) 335-5015

Cell Phone: (626) 824-4546

[michael.allawos@allawosandcompany.com](mailto:michael.allawos@allawosandcompany.com)

[www.allawosandcompany.com](http://www.allawosandcompany.com)



Cole Huber LLP

Scott Huber

3401 Centrelake Drive, Suite 670

Ontario, CA 91761

[shuber@colehuber.com](mailto:shuber@colehuber.com)

(909) 230-4209



Tom Dodson, Environmental Consultant

Tom Dodson & Associates

2150 N. Arrowhead Ave.

San Bernardino, CA 92405

[tda@tdaenv.com](mailto:tda@tdaenv.com)

(909)882-3612

## Section 7: Public Participation

### 7.1 Public Participation

Residents in and around the San Bernardino International Airport have played an important role in our operations and in raising concerns over possible environmental issues. Through the Green Energy Element Plan (GEE), our community will continue to help us progress into a cleaner future. Community members have and will continue to provide important input on points of change they would like to see at the airport. Community support is vital to the success of this GEE, and therefore community members will need to take an active role in providing input on the GEE and monitoring its success over time.

### 7.2 Community Outreach

A variety of outreach tools will allow residents and community members who wish to participate to do so in a comfortable manner. Updates on the GEE can and will be shared with the public the Airport's website and when applicable, through roadshow presentations to the Chamber of Commerce, the partner Cities of the IVDA / SBDA, community-based service clubs, and General Plan Educational Programs that will be made available. Community workshops may include presentations, surveys, group activities, and comments.

#### Leaders In Energy Summit

Leaders in Energy Summit is dedicated to fostering insightful discussions, invaluable networking opportunities, and groundbreaking ideas within the energy sector. Our mission is to bring together industry leaders, innovators, and enthusiasts to explore the future of sustainable energy in the Inland Empire. We invite thought leaders, experts, and changemakers to contribute their insights and be part of this dynamic summit. Our summits focus on critical topics such as:

- Department of Energy Initiatives
- Hydrogen Development and Advancements
- Grid Resiliency/Battery Storage
- Energy Equity and Access
- Public Utilities Commission
- Drone Technology

Section 8: List of Acronyms

8.1 List of Acronyms

AB	Assembly Bill
APS	Alternate Plan Strategy
BAU	Business as usual
BRT	Bus Rapid Transit
BTA	Bicycle Transportation Account
BTP	Bicycle Transportation Plan
CACP	Clean Air Climate Protection
CAFÉ	Corporate Average Fleet Fuel Economy
CAP	Climate Action Plan
CAPCOA	California Air Pollution Control Officers Association
CARB	California Air Resources Board
CCAP	Center for Clean Air Policy
CCAR	California Climate Action Registry
CEC	California Energy Commission
CEQA	California Environmental Quality Act
CFCs	Chlorofluorocarbons
CH <sub>4</sub>	Methane
CIWMB	California Integrated Waste Management Board
CO <sub>2</sub>	Carbon Dioxide
CPUC	California Public Utilities Commission
CSU	California State University
CWIB	California Workforce Investment Board
EIR	Environmental Impact Report
EMFAC2007	California Air Resource Board Emission Factors Model
EO	Executive Order
EPA	Environmental Protection Agency
FCAA	Federal Clean Air Act
FEMA	Federal Emergency Management Agency
GCJC	Green Collar Jobs Council
GHG	Greenhouse Gas
GVW	Gross vehicle weight
GWP	Global Warming Potential
H <sub>2</sub> O	Water, or Water Vapor
HCFCs	Hydrochlorofluorocarbons
HFCs	Hydrofluorocarbons
ICLEI	International Council for Local Environmental Initiatives
IPCC	International Panel on Climate Change
LCFS	Low Carbon Fuel Standard
LEED	Leadership in Energy and Environmental Design
LVW	loaded vehicle weight
MMT	Million metric tons
MPOs	Metropolitan Planning Organizations
MPG	Miles per gallon

MRF	Material Recovery Facility
MSEP	Metrolink Service Expansion Program
MSL	Mean seal level
MT	Metric tons
MTCO <sub>2</sub> eq	Metric tons of carbon dioxide equivalents
MWD	Metropolitan Water District
N <sub>2</sub> O	Nitrous Oxide
NF <sub>3</sub>	nitrogen trifluoride
O <sub>3</sub>	Ozone
OAL	Office of Administrative Law
OPR	Office of Planning and Research
PFCs	Perfluorocarbons
PPM	Parts per million
PPT	Parts per trillion
RPS	Renewable Portfolio Standard
SB	Senate Bill
SCAG	Southern California Association of Governments
SCAQMD	South Coast Air Quality Management District
SCE	Southern California Edison
SF <sub>6</sub>	Sulfur hexafluoride
SCS	Sustainable Communities Strategy
Tg	Teragram
UAS	Unmanned Aircraft Systems
UNFCCC	United Nations Framework Convention on Climate Change
VHFHSZ	Very High Fire Hazard Severity Zones
VMT	Vehicle miles traveled
VTI	Victoria Transport Institute

## Section 9: References & Citations

- [The Intergovernmental Panel on Climate Change is the leading international body for the assessment of climate change:](#)
- [The National Aeronautics and Space Administration \(NASA\) has documented recent impacts and future trends of climate change](#)
- [The U.S. Environmental Protection Agency \(U.S. EPA\) has information of climate change, and its effects:](#)
- [Cal-Adapt, a product of the Public Interest Energy Research \(PIER\) program, funded by the California Energy Commission, provides California-specific climate change research, including interactive climate tools](#)
- [U.S. Environmental Protection Agency \(EPA\) – Climate Change](#)
- [Cool California – Calculator for Households & Individual](#)
- [NOAA Climate Data From Ice Cores](#)
- [Cool Climate Network Carbon Calculator](#)
- [Nature Conservancy - What is your carbon footprint? | Carbon Footprint Calculator](#)
- [Global Footprint Network Carbon Footprint Calculator](#)
- [California Air Pollution Control Officers Association \(CAPCOA\). 2008. CEQA and Climate Change, Evaluating and Addressing Greenhouse Gas Emissions from Projects Subject to the California Environmental Quality Act. Available:](#)
- [California Air Resources Board \(CARB\). 2015. EMFAC2014 Web Database.](#)
- [Educational Resources | California Air Resources Board](#)
- [CARB. 2007. Off-Road Motor Vehicles.](#)
- [California Department of Justice, Office of the Attorney General. 2010. Addressing Climate Change at the Project Level.](#)
- [Commission. 2015. Impact Analysis 2016 Update to the California Energy Efficiency Standards for Residential and Nonresidential Buildings.](#)
- [California Governor’s Office of Planning and Research. 2008. CEQA and Climate Change: Addressing Climate Change Through California Environmental Quality Act.](#)
- [California Public Utilities Commission. 2011. California’s Long-Term Energy Efficiency Strategic Plan. “Chapter 13: Lighting.”](#)
- [Cal-Recycle. 2017. Jurisdiction Diversion/Disposal Rate Summary](#)

	<p><b>TO: San Bernardino International Airport Authority Commission</b></p> <p><b>DATE: April 22, 2026</b></p> <p><b>ITEM NO: 14</b></p> <p><b>PRESENTER: Michael Burrows, Chief Executive Officer</b></p>
---	--

**SUBJECT: CONDUCT BUSINESS PLAN UPDATE WORKSHOP**

**SUMMARY**

An oral report and PowerPoint presentation will be provided at the time of meeting. Commissioner feedback and direction will be requested during the workshop.

**RECOMMENDED ACTION(S)**

Conduct a San Bernardino International Airport Authority (SBIAA) Business Plan workshop and provided feedback and direction to Staff as appropriate, in reference to the prior workshops held on October 22, 2025, December 18, 2025, January 28, 2026, February 25, 2026, and March 25, 2026. The draft final Business Plan update is attached for consideration and review.

**FISCAL IMPACT**

None.

PREPARED BY:	Michael Burrows
CERTIFIED AS TO AVAILABILITY OF FUNDS:	N/A
APPROVED AS TO FORM AND LEGAL CONTENT:	Scott Huber
FINAL APPROVAL:	Michael Burrows

**BACKGROUND INFORMATION**

In 2009, the Inland Valley Development Agency (IVDA) and San Bernardino International Airport Authority (SBIAA) adopted its first Strategic Plan which operated on a five-year and ten-year outlook. In 2015, the SBIAA Commission adopted a new Strategic Plan which centered on revised initiatives, goals, and priorities. These were focused on Priority Projects and Programs for SBD International Airport. Staff have provided annual updates to the Board since the inception of the Strategic Plan. The most recent update was in 2020 wherein the plan was modified to reflect SBIAA Business Plan priorities. Reports on the status of the Action Plan (a subset of the Strategic Plan) are provided monthly.

Staff have been in the process of finalizing the upcoming fiscal year update and story map, which has been presented most recently with the annual budget process. The current SBIAA Business Plan is programmed for an update in 2026. Reports and workshops on core elements of the pending Business Plan Update were held on October 22, 2025, December 18, 2025, January 25, 2026, February 25, 2026, and March 25, 2026.

**Attachments:**

1. PowerPoint Presentation



## San Bernardino International Airport

### Business Plan Update – March 2026 Volume 5

# Impacts of Base Closure



## Economic Impact (1990 – 2010):

- Loss of 15,458 Jobs
- \$1.5 Billion in Annual Payroll
- \$1.9 Billion Loss of Output (Economic Activity)
- About 3% of the 2009 SB Total GDP

## Physical Impact:

- Environmental Clean-up (Federal & Local)
- Replacement of All Utility Systems
- Replacement of All Major Roadways
- Abatement & Demolition of Over 125 buildings

## Phase III Analysis (2020-2026):

- 2024 Update
- 18,693 Direct Jobs
- Over \$5 Billion in Total Economic Output

# Governance Structure

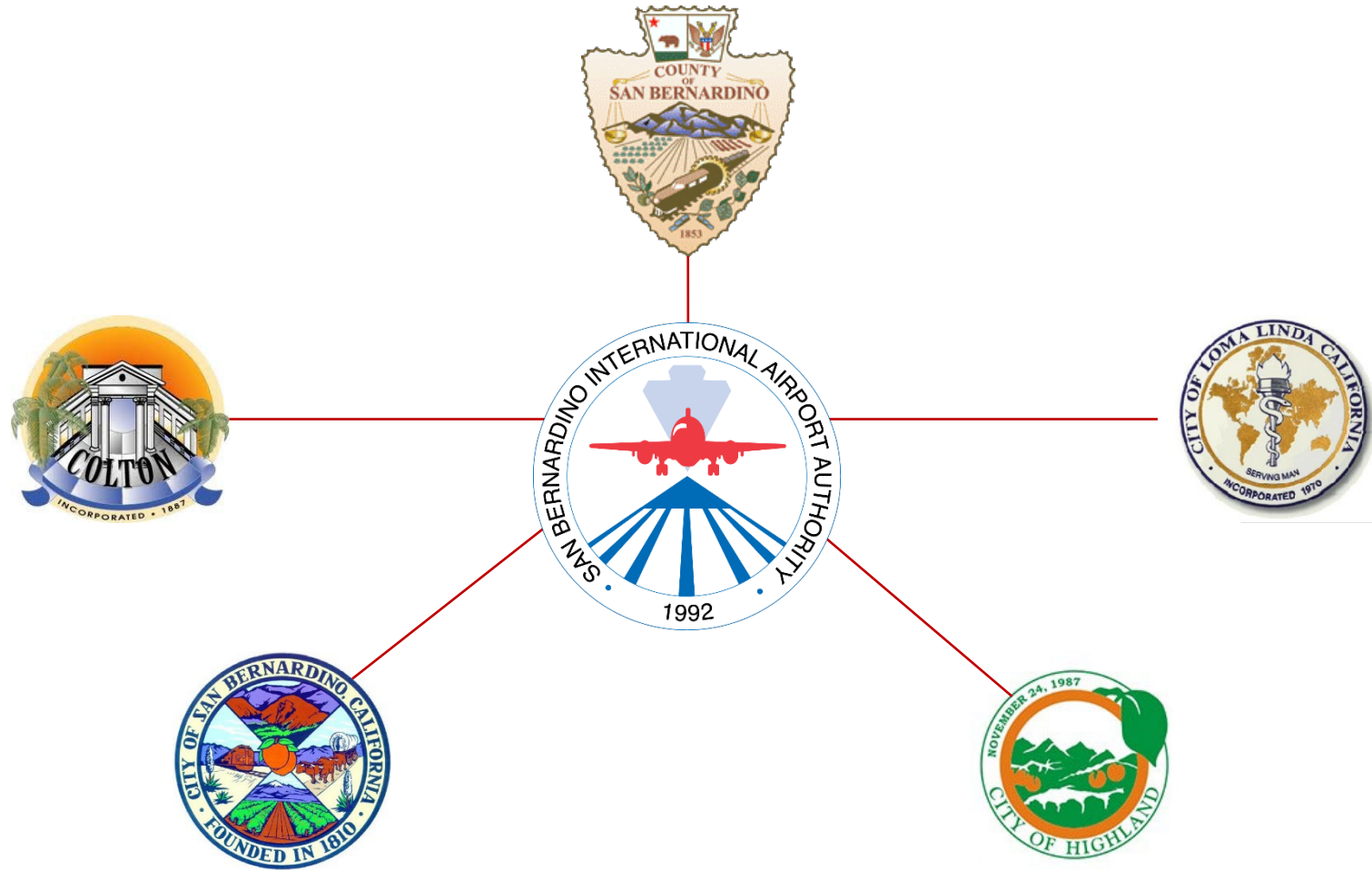

# Leadership Through the Years

- Marshall Julian, Deputy Executive Director – 1992
- William Bopf, Executive Director – 1992
- Trevor Van Horn, Executive Director – 1993 to 1994
- Jim Monger, Airport Director – 1994 to 1997
- William Bopf, Executive Director – 1997 to 1998
- Alex Estrada, Interim Executive Director – 1998
- James W. Gourley, Executive Director – 1998 to 2000
- T. Milford Harrison, Interim Director then made Executive Director – 2000 to 2002
- Donald L. Rogers, Transition Management Team (2003), Interim Executive Director (2004-2009), Executive Director (2010-2011) – 2003 to 2011
- Michael Burrows, Acting Executive Director (2014-2015), Executive Director (2015-2020), Chief Executive Officer (2020-current) – 2014 to current



William  
L. Bopf



A.J.  
Wilson



T. Milford  
Harrison



Michael  
Burrows

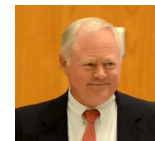

Donald L.  
Rogers

# Business Plan Workshop

## Airport Facts:

- 1) SBD is comprised of over 1,300 acres of FAA regulated land and facilities.
- 2) Since 1997, it has been an FAA Part-139 certificated Airport. Deed covenants and FAA grant assurances require and compel compliance with FAA land use covenants.
  - This includes a restriction requiring that most properties be used for aeronautical purposes
  - Lease transactions Only – No sale of Airport property
  - All revenues generated from Airport property must be used for on-airport purposes – No diversion of Airport revenues
- 3) SBIAA serves as the “Airport Sponsor,” and while in compliance, is eligible for FAA grants.
  - FAA grants are primarily through the Airport Improvement Program (AIP) and can only be used for non-capital projects that improve airport infrastructure, safety, capacity, or security of nonexclusive use facilities
  - Eligibility determined through air cargo and commercial passenger service activity levels
- 4) SBD is also subject to a State of California, Department of Aeronautics Operating Permit.
- 5) SBD operates under a public utility model and generates revenue from leases, fuel sales, and Airport use fees and charges.
- 6) No local taxes are collected or used to fund or operate the Airport.

# Planning Process



2010-2015 Plan

2015-2020 Plan

2020-2025 Plan

Update

# Establishing Priorities

## **Draft Business Plan Update – common themes from Members:**

- 1) Priority Projects:
  - ▶ SBD International Airport
  - ▶ Luxivair SBD
- 2) Align with Resources
- 3) Annual Updates

# Establishing Priorities

- ▶ Diversify revenue streams and sources (aviation, non-aviation, inter-governmental)
  - ▶ Increase revenues by a minimum of 5% per year
  - ▶ Add new customers to Luxivair SBD by a minimum of 10% per year
- ▶ Maintain infrastructure & development support
- ▶ Increase application rate for federal grants (U.S. DOC, U.S. DOT)
- ▶ Implement new airport workforce development programs
- ▶ Implement a new airport capital improvement plan
- ▶ Expand private investment and employment in and at the Airport

# What Do We Consider Results?

- ▶ San Bernardino International Airport is a public airport. It operates under a public utility business model. It serves to ensure compliance with FAA, Military Base Reuse, and General Airport Obligations.
- ▶ It seeks to consistently increase Airport business activity, including aircraft operations, enplanements, fuel sales, and airport services, thus providing investment at the Airport.
- ▶ Airport activity should maximize opportunities for the flying public while achieving fair, non-discriminatory, and equitable revenue returns to support the airport utility over the long run.
- ▶ To accomplish this, SBIAA must create an Airport business environment which supports further investment and employment opportunities for the benefit of the airport, its customers, stakeholders, region, and the National Air Transportation System.
- ▶ SBIAA seeks to ensure that inter-governmental and community support to the San Bernardino International Airport is provided as appropriate.
- ▶ SBIAA should consistently deliver quality airport planning, infrastructure development, community development, and environmental programs, projects, and initiatives.
- ▶ SBIAA seeks to realize its potential to provide high quality, higher wage producing employment opportunities for its member agencies and the communities they serve.
- ▶ Overall business attraction and retention across market segments: MRO, GA, Corporate, Air Cargo, and Commercial Passenger.
- ▶ Transforming the Airport into a best-in-class facility and operation.

# Key Issues

## ▶ Near-term

- ▶ Ever-changing business and regulatory environment
- ▶ Constrained resources
- ▶ Aging infrastructure
- ▶ U.S. Customs – expansion of services
- ▶ Environmental issues

## ▶ Long-term

- ▶ Need to leverage federal and state funding opportunities by working collaboratively and regionally with SBIAA members and stakeholders
- ▶ Programs must be self-funding and sustainable, promoting and advancing regional attributes, goals, and objectives

# Financial Plan

a flight plan for SBIAA...

- ▶ The Plan - Proposed 5-Year and 10-Year Roadmap for the SBIAA
- ▶ Designed to enhance SBIAA strengths and core competencies while minimizing the expenditure of time and resources on non-essential or obsolete programs
- ▶ Focused on business development, retention and customer service—some tenets are uncharted territory for the airport
- ▶ Detailed program schedules are included in the appendices



# Airport Revenues

## Sources of Funds:

- 1) Lease Revenues – Pursuant to Federal Property Transfers
- 2) Luxivair Business Activity – Sale of Fuel, Goods, and Services
- 3) Grant Funds – Predominantly U.S. Department of Transportation, FAA
- 4) Advertising & Parking Fees – Domestic & International Terminals
- 5) Operating Fees – Licenses, Permits, Fees, and Charges (Filming)
- 6) U.S. Customs – Need to Leverage Staff and Equipment Capabilities; Expand services

# New Employment – Direct Jobs

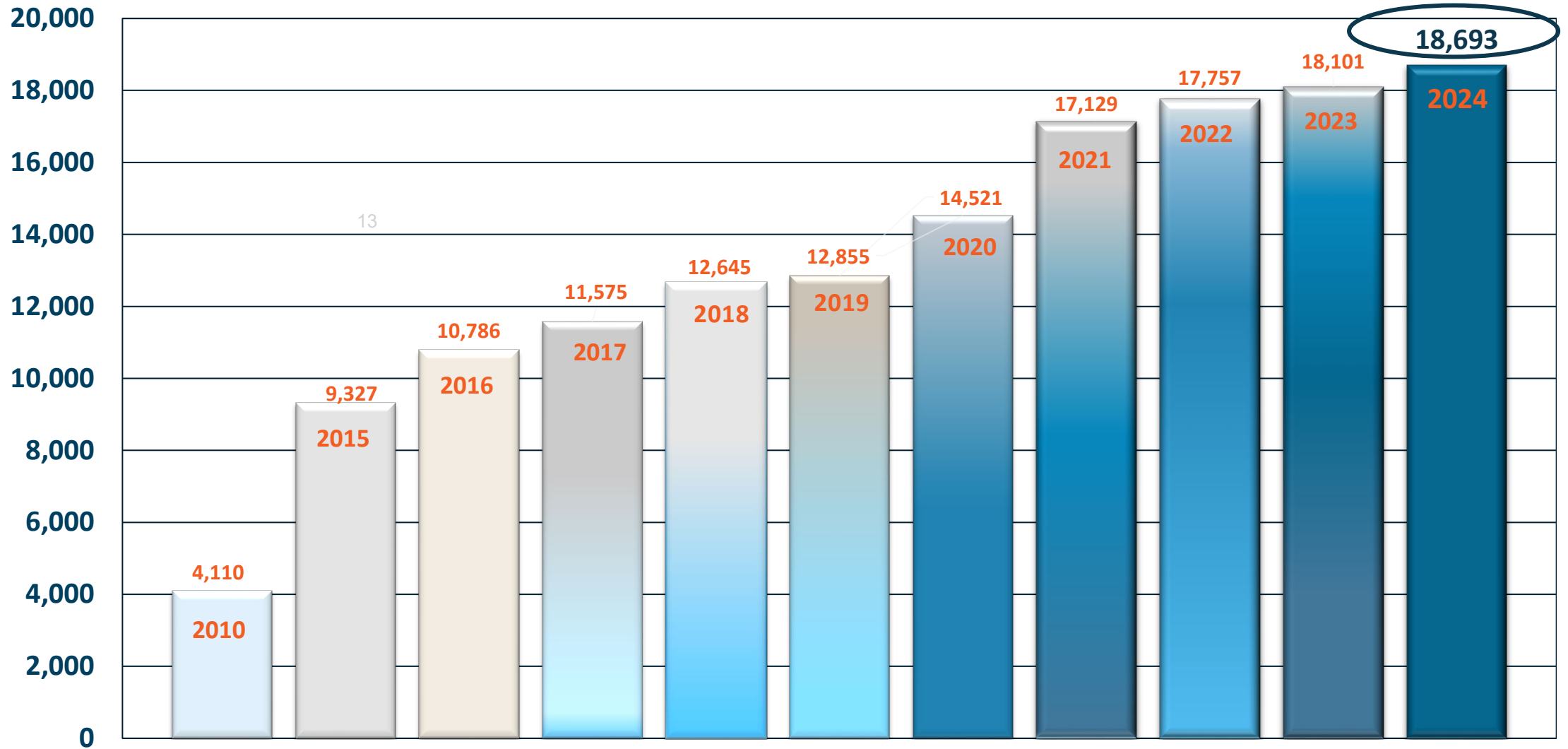

# IMPLAN Analysis 2024

As of 2024, the IVDA project base reuse area has reached a milestone of creating and retaining 18,693 direct jobs. The "IMPLAN - 2024 IVDA Analysis" chart showcases the economic impact of the IVDA project area.

Impact	Employment	Labor Income	Value Added	Output
1 - Direct	18,693.00	\$768,423,999.66	\$2,209,641,595.05	\$3,701,554,712.64
2 - Indirect	5,878.22	\$320,225,903.77	\$472,167,349.09	\$889,263,604.18
3 - Induced	2,751.48	\$142,308,620.85	\$284,819,713.49	\$455,465,358.07
Totals	27,322.70	\$1,230,958,524.28	\$2,966,628,657.62	\$5,046,283,674.89

Display Code	Display Description	Industry Total Output	Impact Output	Percentage of Total Industry Output
1 413	Retail - Nonstore retailers	\$3,311,431,251.62	\$2,445,925,538.82	73.86%
2 414	Air transportation	\$510,295,383.74	\$336,267,914.37	65.90%
3 470	Office administrative services	\$560,659,450.91	\$62,126,353.82	11.08%
4 422	Warehousing and storage	\$8,990,741,959.97	\$856,606,452.62	9.53%
5 462	Management consulting services	\$952,064,232.82	\$82,805,266.98	8.70%
6 465	Advertising, public relations, and related services	\$293,090,785.84	\$18,008,639.34	6.14%
7 420	Scenic and sightseeing transportation and support activities for transportation	\$1,144,406,181.85	\$60,850,782.18	5.32%
8 423	Newspaper publishers	\$19,386,649.71	\$840,182.72	4.33%
9 431	Radio and television broadcasting	\$286,891,372.77	\$11,886,242.28	4.14%
10 526	Postal service	\$270,198,341.84	\$11,042,367.36	4.09%

Top 10 Job Industries

# Aviation Business Partners at SBD - 2026



# Green Energy Element

Re-Imagined in 2020 and implemented in 2021. SBD was early adopter of EV and solar in 2010. SBD's Green Energy Element is going strong.

Acquisition of additional all-electric ground support equipment (tugs, stair truck, lavatory cart, Ford Lightning trucks, hybrid security vehicles, etc.).

10 fleet vehicles upgraded to electric/hybrid.

130 EV Chargers installed throughout the airport and business park under the SCE Charge Ready program with Charge Point – completed in 2024.

Program is aligned with the IVDA UAS Center at SBD, now a focus site for emerging aerospace technologies with SBD based OEM companies.



**Charge Ready**  
How It Works

**ZERO-EMISSION TECHNOLOGY INVENTORY**  
SELECT A VEHICLE PLATFORM TO EXPLORE

SELECT A REGION

SELECT A VEHICLE MANUFACTURER

REPORTED VEHICLE AVAILABILITY THROUGH 2023

Available 2020 2021 2022 2023

# Business Plan Structure

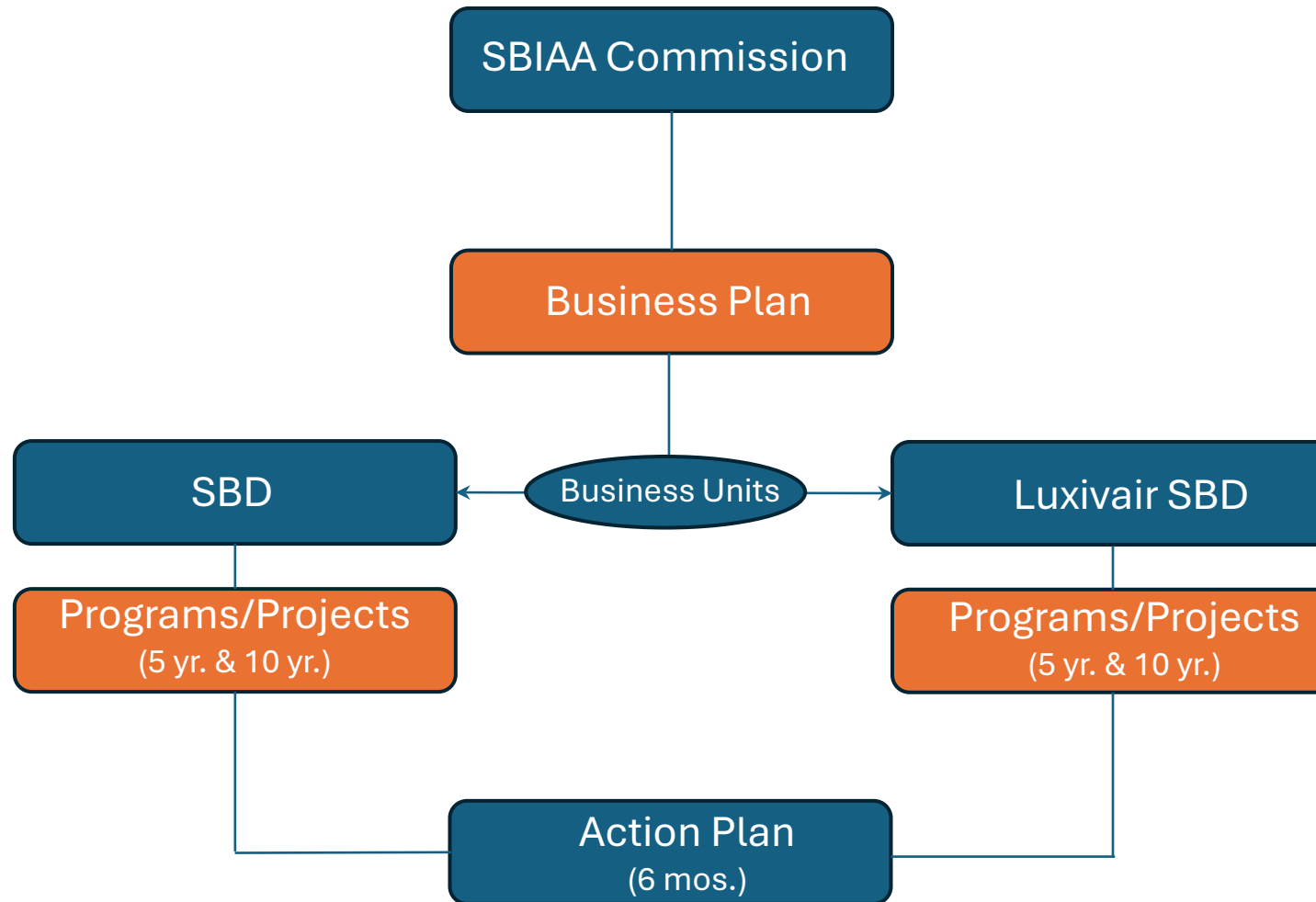

# Operational Business Units: Alignment (2026 - 2031)



## Focal Areas:

- 1) Expanded Passenger Service
- 2) U.S. Customs Staffing Enhancement
- 3) Upgrade Navigational Aids



## Focal Areas:

- 1) Elevate the Customer Experience
- 2) Expanded International Service
- 3) Maintain Steady Growth

# Operational Business Units: (2026 - 2031)



Planning Projects 2026-2031			
#	Project	Est. Completion	Cost
1	SBD Above & Beyond Project (Pre-Build)	2026/27	\$ 300,000
2	Airport Environmental Programs	2027/28	\$ 300,000
3	GA Hangar Expansion (Permitting)	2026/28	\$ 100,000
4	Airport Communication Initiatives	Annual	\$ 200,000
5	Pavement Management Update	2026/28	\$ 300,000
6	Entitlement/ Design of Hangar Expansion Areas (Cargo)	2026/28	\$ 250,000
7	SBD Above & Beyond Project (Permitting & Design/Build)	2027/28	\$ 250,000
8	Environmental Assessment for extension of Runway 6/24 and Taxiway "A"	2028/30	\$ 800,000
9	SBD Good Neighbor Program (YOY)	Annual	\$ 400,000

# Operational Business Units: (2026 - 2031)



<b>Construction Projects 2026-2031</b>			
<b>#</b>	<b>Project</b>	<b>Est. Completion</b>	<b>Cost</b>
1	Reconstruct Portion of Taxiway (A) FAA	2026/27	\$ 4,510,612
2	Inter-Terminal Pedestrian Walkway	2026/27	\$ 150,000
3	Pavement Mangement Plan Update (FAA)	2026/27	\$ 292,300
4	Slurry Seal & Airfield Striping Project (FAA)	2026	\$ 3,275,708
5	Airfield Drainage Channel Repairs (City Creek)	2027/28	\$ 3,100,000
6	Construct Apron Pavement in East GA Area (Phase II)	2027/28	\$ 500,000
7	SBD Above & Beyond Project	2026/27	\$ 6,000,000
8	Airport Operations/ Maintenance Vehicle Replacements	Annual	\$ 250,000
9	Airport Operations Communications Upgrades	Annual	\$ 150,000
10	General Aviation Hangar Construction - Phase III	2026/28	\$ 1,000,000
11	Reconstruct North Airport Ramp (2026)	2026/27	\$ 3,000,000
12	FAA ARFF Response Vehicle (2027)	2026/27	\$ 1,300,000
13	Reconstruct Runway Stopways (2027)	2027/28	\$ 3,500,000
14	Airport Navaid Upgrades	2027/30	\$ 375,000
15	Airport Security Vehicle Replacements	Annual	\$ 200,000
16	Fiberoptic Network Repairs/ Upgrades	Annual	\$ 150,000

# Operational Business Units: (2026 - 2031)



Planning/Maintenance Projects 2026-2031			
#	Project	Est. Completion	Cost
1	Community Programs	2026/27	\$ 250,000
2	Luxiivair SBD Business Plan Support	Annual	\$ 30,000
3	Alternative Fuel Vehicle & Equipment Upgrades (EV/GSE)	2026/28	\$ 600,000
4	Solar Upgrades	2027/28	\$ 110,000
5	Customer Service & Financial Training	Annual	\$ 50,000
6	Computer/ Network Upgrades (FBO & Fuel Farm)	2026/28	\$ 50,000
7	POS/ Tablet System Upgrades	2026/29	\$ 25,000
8	Luxiivair SBD Lighting Upgrades	2026/27	\$ 50,000
9	Concession Design & Entitlement	2027/28	\$ 120,000

# Operational Business Units: (2026 - 2031)



Development Projects 2026-2031			
#	Project	Est. Completion	Cost
1	Signage (on-site & airfield)	2026/28	\$ 75,000
2	Baggage Tractor (EV)	2026/29	\$ 82,000
3	Relocate Blast Fence	2027/29	\$ 50,000
4	Towbars	2027/29	\$ 30,000
5	Belt Loader	2027/29	\$ 81,000
6	Fuel Farm Lighting/ Awnings	2027/28	\$ 80,000
7	Airport Ramp Upgrades	2027/28	\$ 350,000
8	Courtesy Shuttle Van	2028/29	\$ 120,000
9	Baggage Tractor (EV)	2027/28	\$ 60,000
10	Parking Lot Improvements	2027/28	\$ 150,000
11	Concession Improvements	2027/29	\$ 2,500,000
12	Tug Upgrade	2027/29	\$ 120,000
13	Fuel Truck Upgrades	2028/29	\$ 500,000
14	GSE Upgrade	Annual	\$ 750,000
15	Striping Project	2026/29	\$ 100,000
16	FF &E Replacement	2027/29	\$ 250,000
17	Box Hangar Construction	2027/29	\$ 6,500,000
18	Construct FBO Ramp & Apron	2027/30	\$ 2,000,000
19	Solar System Installation	2028/29	\$ 1,300,000
20	Courtesy Car replacements	2026/30	\$ 250,000

# Appendices



# AIRPORT

## San Bernardino International Airport Authority Proposed Projects for FY 2026-31

#	Project	Est. Cost	2026				2027				2028				2029				2030			
			1st QTR	2nd QTR	3rd QTR	4th QTR	1st QTR	2nd QTR	3rd QTR	4th QTR	1st QTR	2nd QTR	3rd QTR	4th QTR	1st QTR	2nd QTR	3rd QTR	4th QTR	1st QTR	2nd QTR	3rd QTR	4th QTR
<b>Planning Projects</b>																						
1	SBD Above & Beyond Project (Pre-Build)	\$ 300,000																				
2	Airport Environmental Programs	\$ 300,000																				
3	GA Hangar Expansion (Permitting)	\$ 100,000																				
4	Airport Communication Initiatives	\$ 200,000																				
5	Pavement Management Update	\$ 500,000																				
6	Entitlement/ Design of Hangar Expansion Areas (Cargo)	\$ 250,000																				
7	SBD Above & Beyond Project (Permitting & Design/Build)	\$ 250,000																				
8	Environmental Assessment for extension of Runway 6/24 and Taxiway "A"	\$ 800,000																				
9	SBD Good Neighbor Program (YOY)	\$ 400,000																				
Planning Projects - Total		\$ 2,800,000																				
<b>Construction Projects - 5 Year</b>																						
10	Reconstruct Portion of Taxiway (A) FAA	\$ 4,510,612																				
11	Inter-Terminal Pedestrian Walkway	\$ 150,000																				
12	Pavement Management Plan Update (FAA)	\$ 292,300																				
13	Slurry Seal & Airfield Striping Project (FAA)	\$ 3,275,708																				
14	Airfield Drainage Channel Repairs (City Creek)	\$ 3,100,000																				
15	Construct Apron Pavement in East GA Area (Phase II)	\$ 500,000																				
16	SBD Above & Beyond Project	\$ 6,000,000																				
17	Airport Operations/ Maintenance Vehicle Replacements	\$ 250,000																				
18	Airport Operations Communications Upgrades	\$ 150,000																				
19	General Aviation Hangar Construction - Phase III	\$ 1,000,000																				
20	Reconstruct North Airport Ramp (2026)	\$ 3,000,000																				
21	FAA ARFF Response Vehicle (2027)	\$ 1,300,000																				
22	Reconstruct Runway Stopways (2027)	\$ 3,500,000																				
23	Airport Navaid Upgrades	\$ 375,000																				
24	Airport Security Vehicle Replacements	\$ 200,000																				
25	Fiber optic Network Repairs/ Upgrades	\$ 150,000																				
26	Airport Security Upgrades (TSA, Video, Etc.)	\$ 350,000																				
27	Replace AWOS III (2027)	\$ 250,000																				
28	Airport Parking Lot/ revenue Control Repairs/ Upgrades	\$ 200,000																				
29	Reconstruct Taxiway C (2028)	\$ 12,000,000																				
30	Reconstruct General Aviation Ramp (2029)	\$ 2,500,000																				
31	Terminal Solar Upgrades (REPAIR/UPDATE)	\$ 240,000																				
32	Air Traffic Control Tower Upgrades	\$ 500,000																				
33	Domestic Terminal Jet bridge Replacements	\$ 3,000,000																				
34	Airport Security Building Rehabilitation	\$ 300,000																				
35	Airport Maintenance Equipment Upgrades	\$ 125,000																				
36	Airfield Drainage Improvement Project	\$ 1,100,000																				
37	Reconstruct Taxiway B	\$ 11,000,000																				
38	Construct Heliport	\$ 600,000																				
39	Airport Master Plan Update (2031)	\$ 1,100,000																				
40	Construct Apron - Phase II	\$ 3,900,000																				
41	Air Traffic Control Service Radar Feed Upgrade	\$ 2,000,000																				
42	Improve General Aviation Utility Infrastructure	\$ 2,000,000																				
43	Construct Corporate Hangar Development Infrastructure	\$ 1,004,000																				
44	Construct Taxiway Extension Leading to Hangar Development in GA Area	\$ 684,000																				
45	Construct General Aviation Hangars - Phase III (Hangars)	\$ 3,500,000																				
46	Construct Terminal Building Concourse - Phase II (3 gates)	\$ 11,700,000																				
47	GRID Resiliency Upgrades	\$ 6,500,000																				
48	Rehabilitate Various Taxiway and Apron Pavements (Various Phases)	\$ 10,000,000																				
Construction Projects - 5-Year Total		\$ 102,306,620																				
5-Year Planning and Construction Projects - Total		\$ 105,106,620																				
<b>Construction Projects - 10 Year</b>																						
49	Airport Maintenance Vehicle Replacement	\$200,000																				
50	Construct Parallel Rwy 6R-24L for General Aviation Use (4,600'x75')	\$ 15,131,000																				
51	Install PAPI-2s and REILS on Runway 6R-24L	\$ 317,000																				
52	Expand Fuel Farm Facility - Phase II	\$3,900,000																				
53	Construct Terminal Building Concourse - Phase III (3 Gates)	\$ 11,700,000																				
54	Construct Air Cargo Apron - Phase II	\$ 4,579,000																				
55	Repave Perimeter Road	\$ 1,552,000																				
56	Construct Air Cargo Facility/Buildings/Parking - Phase II	\$ 23,610,000																				
57	Construct Taxiways Leading to Hangar Development in GA Area	\$ 2,000,000																				
58	Construct General Aviation Hangars - Phase IV	\$5,200,000																				
59	Remove Existing Building Infrastructure in East GA Area	\$3,026,000																				
60	Construct Taxilane Leading to Airfield Access Revenue Support Parcels	\$ 214,000																				
61	Rehabilitate Various Taxiway and Apron Pavements	\$ 10,000,000																				
Construction Projects - 10 Year Total		\$ 81,429,000																				
Planning and Construction Projects - Total		\$ 186,535,620																				
<b>Evaluation/Assessment - Plan Update</b>																						
	Eligible for grant or partner funding																					
	Local/Other Funds/P3																					



# LUXIVAIR SBD

#	Project	Est. Cost	2026				2027				2028				2029				2030			
			1st QTR	2nd QTR	3rd QTR	4th QTR	1st QTR	2nd QTR	3rd QTR	4th QTR	1st QTR	2nd QTR	3rd QTR	4th QTR	1st QTR	2nd QTR	3rd QTR	4th QTR	1st QTR	2nd QTR	3rd QTR	4th QTR
<b>Planning/ Maintenance Projects</b>																						
1	Community Programs	\$ 250,000																				
2	Luxivair SBD Business Plan Support	\$ 30,000																				
3	Alternative Fuel Vehicle & Equipment Upgrades (EV/GSE)	\$ 600,000																				
4	Solar Upgrades	\$ 110,000																				
5	Customer Service & Financial Training	\$ 50,000																				
6	Computer/ Network Upgrades (FBO & Fuel Farm)	\$ 50,000																				
7	POS/ Tablet System Upgrades	\$ 25,000																				
8	Luxivair SBD Lighting Upgrades	\$ 50,000																				
9	Concession Design & Entitlement	\$ 120,000																				
Planning/ Maintenance Projects - Total		\$ 1,285,000																				
<b>Development Projects - 5 Year</b>																						
10	Signage (on-site & airfield)	\$ 75,000																				
11	Baggage Tractor (EV)	\$ 82,000																				
12	Relocate Blast Fence	\$ 50,000																				
13	Towbars	\$ 30,000																				
14	Belt Loader	\$ 81,000																				
15	Fuel Farm Lighting/ Awnings	\$ 80,000																				
16	Airport Ramp Upgrades	\$ 350,000																				
17	Courtesy Shuttle Van	\$ 120,000																				
18	Baggage Tractor (EV)	\$ 60,000																				
19	Parking Lot Improvements	\$ 150,000																				
20	Concession Improvements	\$ 2,500,000																				
21	Tug Upgrade	\$ 120,000																				
22	Fuel Truck Upgrades	\$ 500,000																				
23	GSE Upgrade	\$ 750,000																				
24	Striping Project	\$ 100,000																				
25	FF & E Replacement	\$ 250,000																				
26	Box Hangar Construction	\$ 6,500,000																				
27	Construct FBO Ramp & Apron	\$ 2,000,000																				
28	Solar System Installation	\$ 1,300,000																				
29	Courtesy Car replacements	\$ 250,000																				
Business Development Projects - 5 Year Total		\$ 15,348,000																				
5 Year Business Development Projects - Total		\$ 16,633,000																				
<b>Business Development Projects - 10 Year</b>																						
30	Gate Operator Upgrades	\$ 30,000																				
31	Communications Upgrades	\$ 75,000																				
32	Software Upgrades	\$ 100,000																				
33	Courtesy Car replacements	\$ 150,000																				
34	FF & E Replacements	\$ 150,000																				
35	Alternative Fuel Vehicle & Equipment Upgrades	\$ 500,000																				
36	Generator Replacement/Upgrades	\$ 250,000																				
Business Development Projects - 10 Year Total		\$ 1,255,000																				
Business Development Projects - Total		\$ 17,888,000																				
<b>Evaluation/Assessment - Plan Update</b>																						
	Eligible for grant or partner funding																					
	Local/Other/P3																					

	<p><b>TO: San Bernardino International Airport Authority Commission</b></p> <p><b>DATE: April 22, 2026</b></p> <p><b>ITEM NO: 15</b></p> <p><b>PRESENTER: Michael Burrows, Chief Executive Officer</b></p>
---	--

**SUBJECT: REVIEW STATUS OF THE ACTION PLAN FOR THE SAN BERNARDINO INTERNATIONAL AIRPORT AUTHORITY (SBIAA) THROUGH JUNE 30, 2026**

**SUMMARY**

On December 16, 2015, the SBIAA Commission adopted a Strategic Plan and in January 2020 updated its Business Plan and near-term outlook. These helped identify key dates and deliverables in an effort to focus San Bernardino International Airport Authority (SBIAA) Staff and Resources to increase organizational, operational efficiencies and results.

**RECOMMENDED ACTION(S)**

Review the Action Plan for the San Bernardino International Airport Authority (SBIAA) through June 30, 2026.

**FISCAL IMPACT**

None. The proposed plan identifies staff resources for which funding is included in the General Fund of the adopted San Bernardino International Airport Authority (SBIAA) Budget for Fiscal Year 2025-2026.

PREPARED BY:	Michael Burrows
CERTIFIED AS TO AVAILABILITY OF FUNDS:	Mark Cousineau
APPROVED AS TO FORM AND LEGAL CONTENT:	Scott Huber
FINAL APPROVAL:	SBIAA Commission

## **BACKGROUND INFORMATION**

The Action Plan identifies key dates and deliverables in an effort to focus San Bernardino International Airport Authority (SBIAA) Staff and Resources to increase organizational and operational efficiencies.

This status is offered for consideration and review. Updates and adjustments should be made, as appropriate, at each monthly interval.

For review and discussion.

### **Attachments:**

1. SBIAA Action Plan

# June 30, 2026 – Airport Focal Areas



Ensure Operational & Financial Stability

Stabilize Revenue Streams & Sources

Good Neighbor Program

Airport Outreach:

Business Retention & Expansion

EV & Solar Projects

FAA Taxiway Project

Grant Programs & Initiatives

International Trade

Business Plan Update



# San Bernardino International Airport Authority

## Draft Action Plan for SBIAA (6/30/26)

Month	Key Initiative	Key Resources	Completion Date
January, 2026	Airport Operations Update; FAA Reporting; Good Neighbor Report	SBIAA Commission, CEO, Director of Aviation, Airport Manager, Director of Finance	January, 2026
February , 2026	Mid-Year Budget Adjustments; FAA Emergency Exercise	Director of Aviation, Airport Manager, Director of Finance, Director of Administration	February, 2026
March, 2026	Annual Audit; Legislative Updates; Operational Updates	CEO, Director of Administration, Director of Aviation, Director of Finance	March, 2026
April, 2026	Grant Program & Initiatives; Green Energy Element Update	Director of Finance, Director of Aviation, Project Manager	April, 2026
May, 2026	International Trade Initiatives; Draft Annual Budget Preparation and Review	SBIAA Commission & Committee, CEO, Director of Finance, Exec Staff	May, 2026
June, 2026	Adopt Annual Budget	SBIAA Commission & Committee, CEO., Aviation Director, Director of Finance, Exec Staff	June, 2026

- Critical Path for Commission Buy-In & Implementation; Aggressive Timeline May Impact Capital Plan

# SBIAA Near-Term Action Plan – Implementation



Sub-Initiative Status:



Incomplete

In Process

Completed

